

FOR ENERGY EFFICIENT INNOVATIONS

THINK ON.

www.onsemi.com

XGS Image Sensor Family

November 2020

Public Information



XGS Image Sensor Family

Integrated portfolio of high performance, low noise image sensors

- High bandwidth, lower power architecture
- True global shutter
- Industry-leading image quality
- 11 Resolutions available, ranging from 2Mp up to 45 Mp
- One camera design supports multiple resolutions and configurations

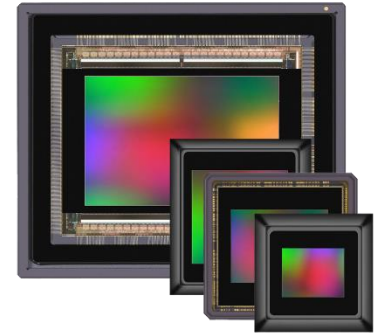

General Purpose Machine Vision



ITS



Broadcast

Key take aways XGS product family

Aggressive price settings:

- Exceeds market expectations
- No price differentiation between color and monochrome devices
- Pretty flat price curve, limited volume dependency

Value proposition:

- Family concept: one footprint supports all resolutions from 2Mp up to 16Mp, while a second footprint supports a 20Mp up to a 45Mp solution
- All XGS family member have the same 'look and feel' (IP reuse)
- High degree of footprint compatibility
- Better than 'state of the art' power dissipation
- 29x29mm² camera format compatible (XGS 2000 – XGS 16000)
- Dedicated versions available for the ITS market segments, having an optimized CRA to reduce roll-off in the sensor corners

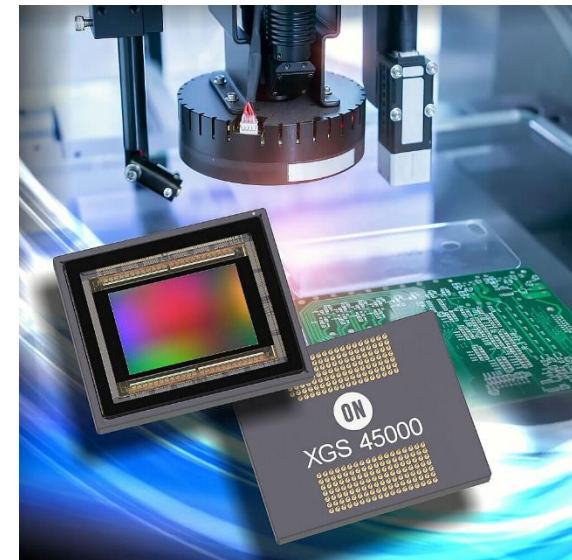
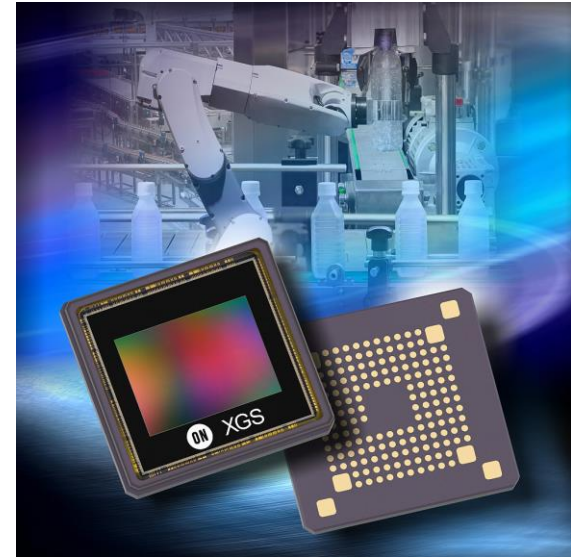

XGS Family overview

XP24
29 x 29 mm² compatible

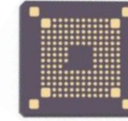

XP48

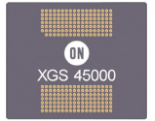

	XGS 2000	XGS 3000	XGS 5000	XGS 8000	XGS 9400	XGS 12000	XGS 16000
Resolution (x,y)	1920 x 1200	2048 x 1536	2592 x 2048	4096 x 2160	3072 x 3072	4096 x 3072	4000 x 4000
Resolution (Mp)	2.3	3.1	5.3	8.8	9.4	12.6	16.0
Imaging Diagonal (mm)	7.3	8.2	10.6	14.8	13.9	16.4	18,1
Optical Format	1/2.2	1/2	2/3	1/1.1	1/1.2	1	1.1"
Max Frame Rate (12 bit)	220	175	132 & 43	128 & 80	90 & 56	90 & 28	65 & 21
Shutter Type	Global						
Pixel Size (µm)	3.2						
Linear Full Well (e-)	10,100						
Dark Temporal Noise (e-)	4.0 (default gain); 1.9 (4x gain)						
Dynamic Range (dB)	68.4 (EMVA 66.9)						
QE (%)	62%						
SNR max (dB)	40						
Dark Current (Tj=60 °C)	PD: 80 e-/s, SN: 20 e-/s						
GSE	~ 4000:1						
Channel Mux	16,12,8,4			24, 18, 12, 6			24, 18, 12, 6
Power dissipation	< 1000 mW for highest speed grade			<900 mW at full speed			≤ 1200 mW
Package Options	iLGA, < 16 x 16 mm ²			163 pin cLGA, 21 x 20 mm ²			163p iLGA
ADC Bit Depth	12-bit, 10-bit			12-bit, 10-bit			12-/10-bit
CFA Options	Mono, Bayer			Mono, Bayer			Mono, Bayer
CRA Options	0 degree	4.7 degree	0/4.7 degree	0/7.3 degree	0 degree	0/7.3 degree	0 degree
Speed Grade	✓		✓	✓	✓	✓	✓
Evaluation Kit	✓	✓	✓	✓	✓	✓	✓

XGS 20000	XGS 30000	XGS 32000	XGS 45000
4500 x 4500	5460 x 5460	6580 x 4935	8192 x 5460
20	30	32	45
20.4 mm	24.9 mm	26.3 mm	31.6 mm
4/3"	~ APS-C	APS-C	Super 35mm
57 & 38	47 & 30	53 & 35	47 & 30 & 15
Global			
3.2			
10,100			
4.25 (default gain); ~ 2.0 (max gain)			
67.2			
62%			
40			
PD: 90 e-/s, SN: 49 e-/s			
~ 4000:1			
48,36,24,12			
<2.1 W @ max fps			
338 µPGA, 46.5 x 39.5 mm ²			
12-bit, 10-bit			
Mono, Bayer			
10 degree			
✓	✓	✓	✓
✓	✓	✓	✓



XGS 32000

Cost efficient High Resolution 4:3 XGS Sensor

- New high resolution XGS option has been added to the family
- XGS 32000, rectangular 4:3 aspect ratio, 6580x4935 pixels
- Markets: high end ITS, security, FA, FPD inspection and more

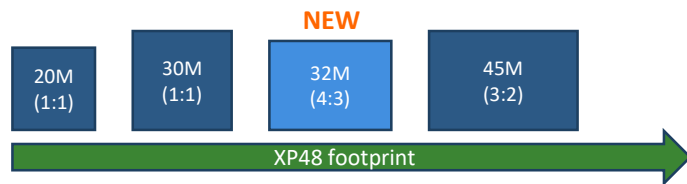

	XGS 32000	XGS Benefits		
		DR	fps (12-b)	Other remark
KAI-29050 @ MP	✓	+4 / +11 dB	13x	CMOS integration, power efficiency, ASP
KAI-16050 @ MP		+4 / +11 dB	9.2x	4/3", CMOS integration, power efficiency, ASP
KAI-08050 @ OF	✓	+4 / +11 dB	3.3x	4/3", CMOS integration, power efficiency, ASP
IMX387 (16.9M) @ MP		-2 / + 3 dB	1.9x	XGS power efficiency, ASP, scales to 45MP
IMX367 (19.7M) @ MP		-2 / + 3 dB	2.7x	XGS power efficiency, ASP, scales to 45MP
IMX342 (31.5M) @ MP	✓	-2 / + 3 dB	2.1x	XGS power efficiency, ASP, scales to 45MP
CMV8000 @ OF	✓	+6 / +13 dB	0.7x(**)	XGS power efficiency, ASP, scales to 45MP

	XGS 20000	XGS 30000	XGS 32000	XGS 45000
Resolution (x,y)	4500 x 4500	5460 x 5460	6580 x 4935	8192 x 5460
Resolution (Mp)	20	30	32	45
Imaging Diagonal (mm)	20.4 mm	24.9 mm	26.3 mm	31.6 mm
Optical Format	4/3"	~ APS-C	APS-C	Super 35mm
Max Frame Rate (12 bit)	57 & 38	47 & 30	53 & 35	47 & 30 & 15
Shutter Type	Global			
Pixel Size (µm)	3.2			
Linear Full Well (e-)	10,100			
Dark Temporal Noise (e-)	4.25 (default gain); ~ 2.0 (max gain)			
Dynamic Range (dB)	67.2			
QE (%)	62%			
SNR max (dB)	40			
Dark Current (Tj=60 °C)	PD: 90 e-/s, SN: 49 e-/s			
GSE	~ 4000:1			
Channel Mux	48,36,24,12			
Power dissipation	<2.1 W @ max fps			
Package Options	338 µPGA, 46.5 x 39.5 mm ²			
ADC Bit Depth	12-bit, 10-bit			
CFA Options	Mono, Bayer			
CRA Options	10 degree			
Speed Grade	✓	✓	✓	✓
Evaluation Kit	✓	✓	✓	✓



High Resolution with High Framerate

8K video mode at 60fps

Competitor Gen 1

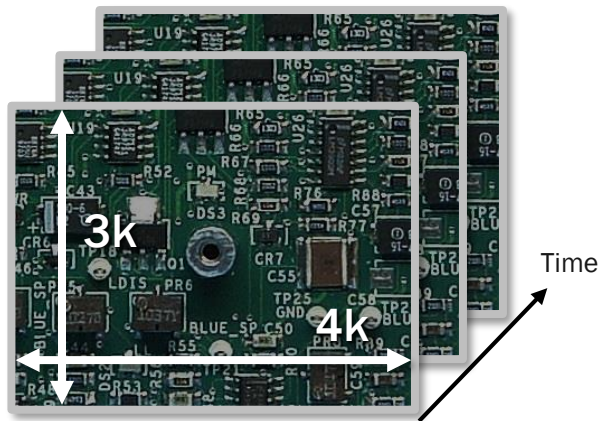

552 megapixels / sec

Competitor Gen 2

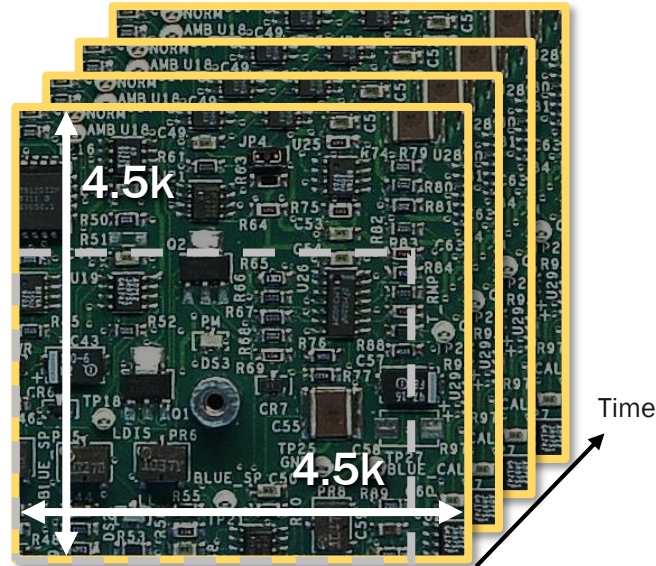

1360 megapixels / sec

XGS 45000

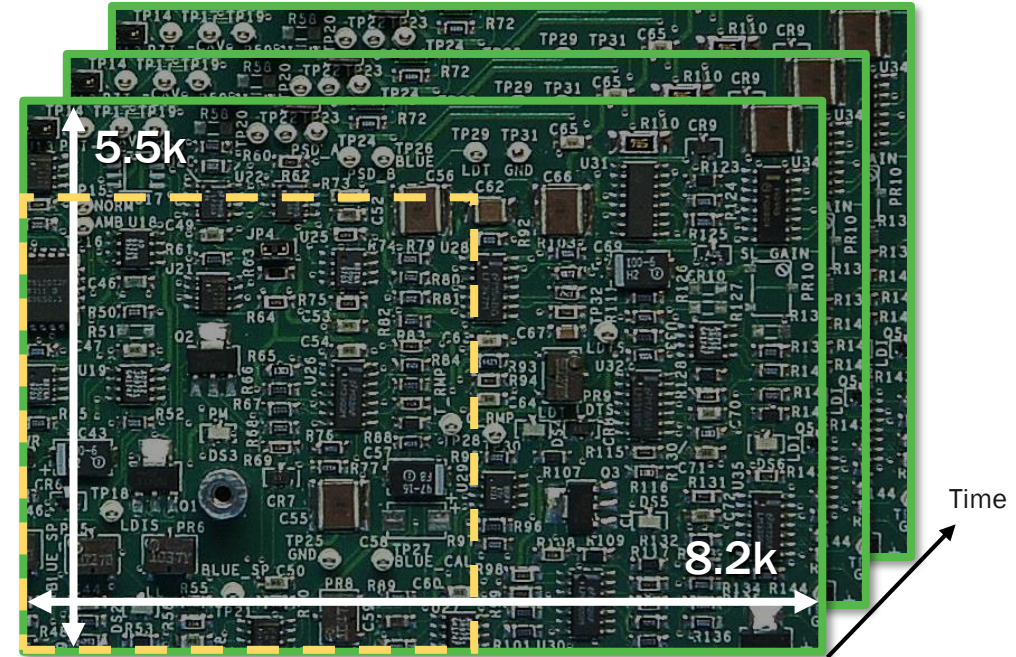

2160 megapixels / sec

	Resolution (Mp)	12-bit fps	Total Mpix/s	Relative Speed
Competitor Gen 1	12	46	552	1.0
Competitor Gen 2	20	68	1360	2.5
XGS 45000	45	48	2160	3.9



Key Specifications

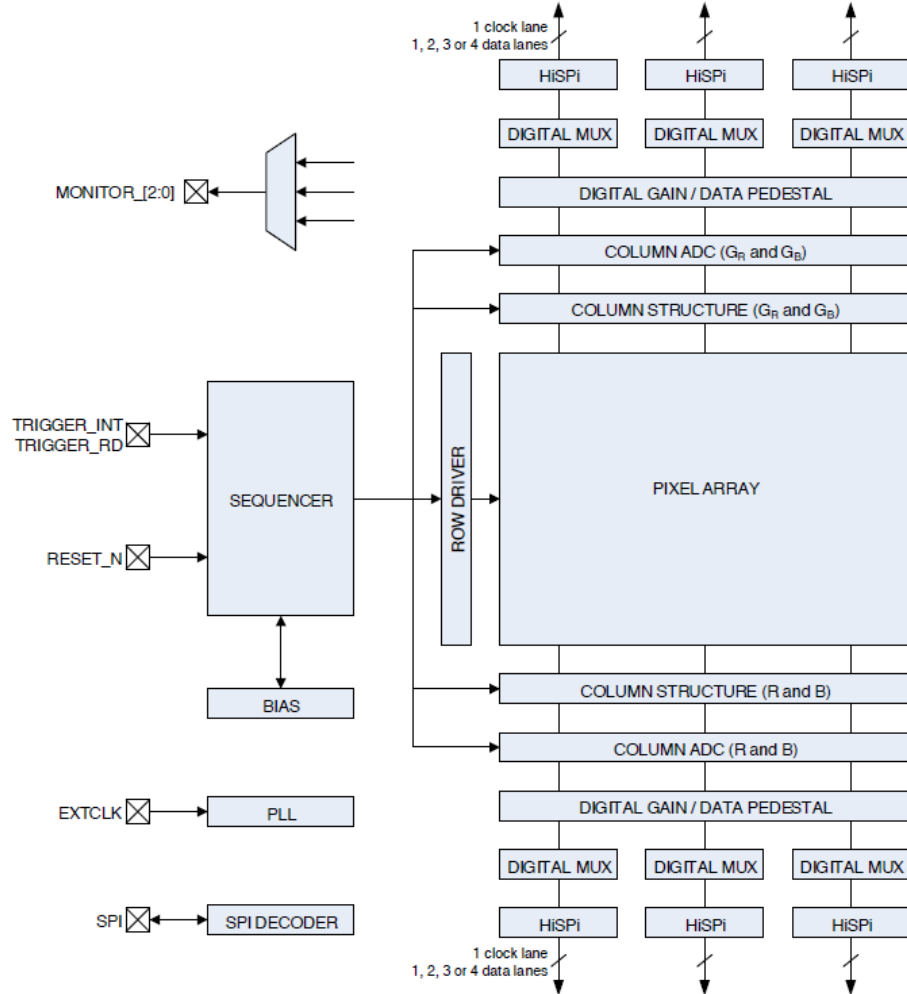

Parameter	Specification
Pixel Size	3.2 μm x 3.2 μm
Shutter Type	Global Shutter
Global Shutter Efficiency (550 nm)	> 4000:1
Full Well Capacity (linear)	10.1 ke ⁻
Quantum Efficiency (peak)	
Mono (550 nm, 850 nm)	62%, 20% (incl. cover glass)
Color (455 nm, 545 nm, 600 nm)	48%, 58%, 58% (incl. cover glass)
Dynamic range	68 dB
Read noise	
1x Analog gain	4.0 e ⁻ rms
Column FPN	< 1/10x Read Noise (1x analog gain)
Row Temporal Noise	< 1/10x Read Noise (1x analog gain)
PRNU	2.3% (global)
Dark current (storage node)	80 e ⁻ /s @ 60 °C (PD only)
Data Interface	HiSPi; up to 24 channel mux
Master Input Clock	32.4 MHz
ADC Resolution	12 bit
Input voltage requirements	3.0 V, 2.8 V, 1.8 V, 1.2 V, (0.4 V optional)
Operational Temperature Range	-40 °C to 85 °C (ambient)

Note: Specifications may show minor variation with different product resolutions

Chief Ray Angles (CRA) Optimized for Different Use Cases

Application	CRA	Devices
Machine Vision	Telecentric (0°)	<ul style="list-style-type: none"> XGS 16000 and lower
ITS	Options available	<ul style="list-style-type: none"> XGS 12000 (0°/7.3°) XGS 8000 (0°/7.3°) XGS 5000 (0°/4.7°) XGS 3000 (0°/4.7°)
Large Format	Default offset of 10° for all variants	<ul style="list-style-type: none"> XGS 45000 XGS 30000 XGS 20000

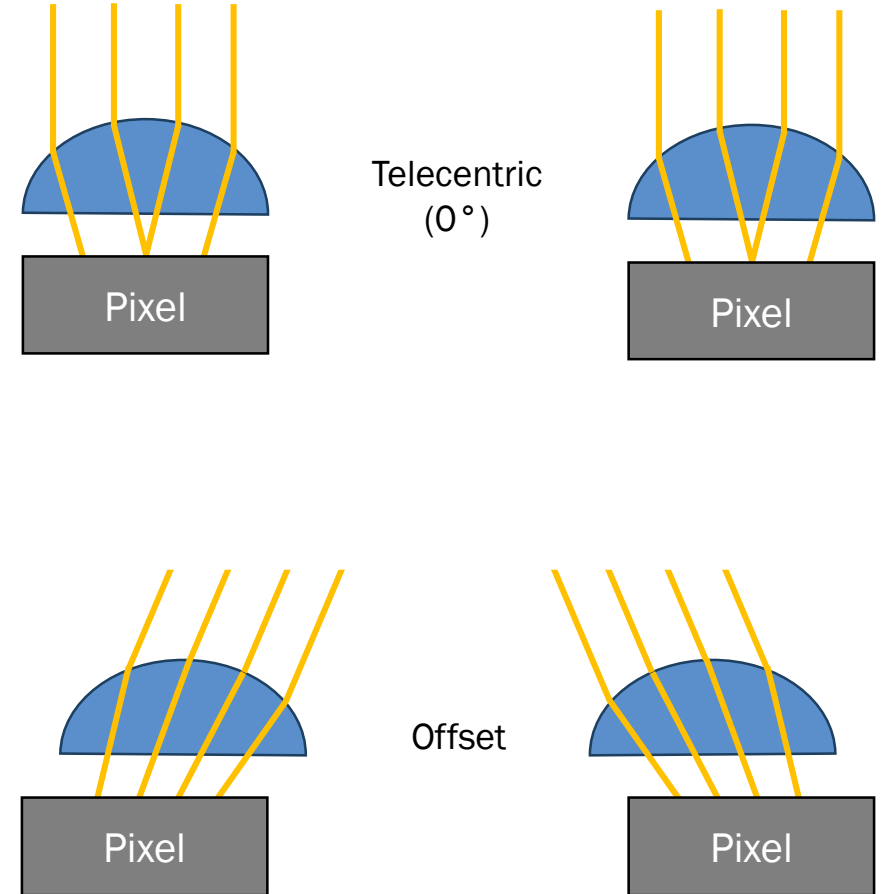

XGS – XP24 for 29 x 29 mm² cameras

3 Package variants (NOT TO SCALE)

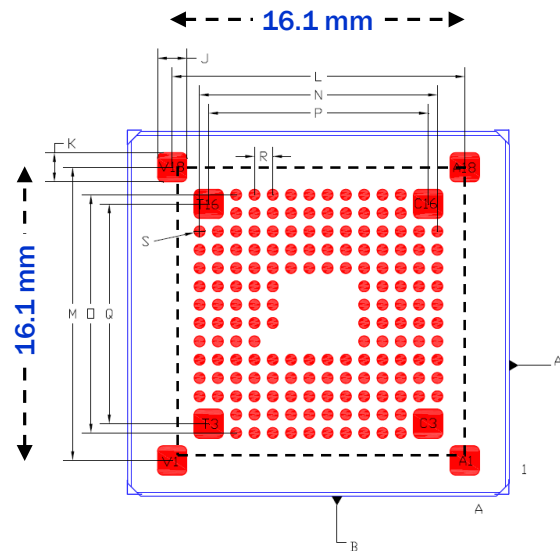

XGS 2000 – 3000 - 5000 iLGA

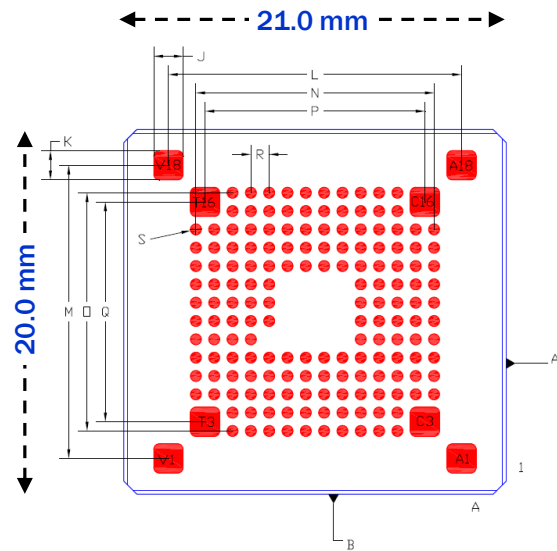

XGS 8000 – 9400 - 12000 cLGA

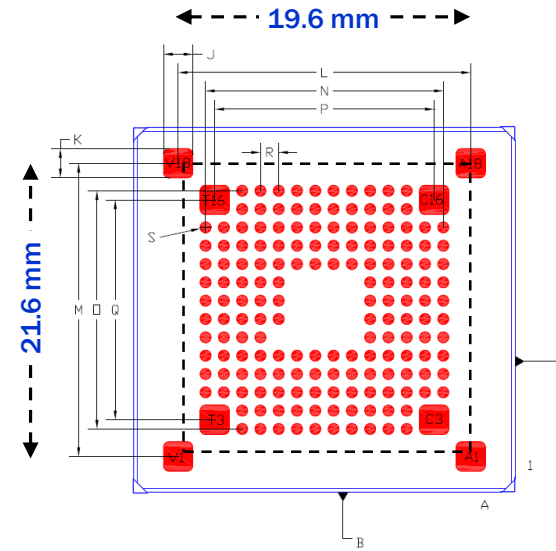

XGS 16000 iLGA

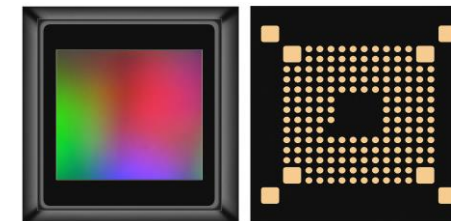

ALL dimensions INCLUDE tolerance

New camera interfaces drive higher frame rates: XGS is a step ahead

XGS ≤ 1.1" view

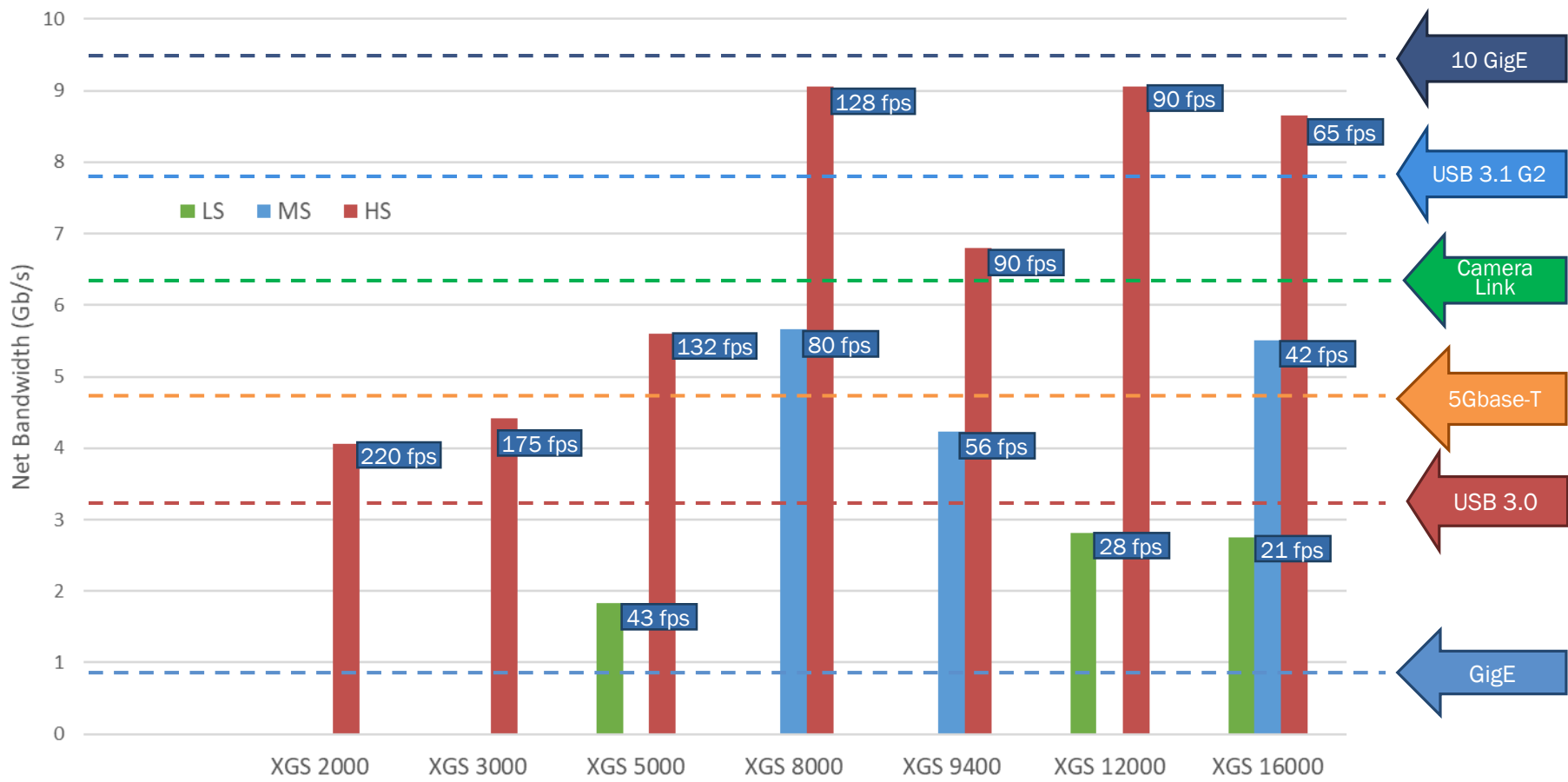

COMPANDING MODE

- Increases speed for lower speed grades
- Compresses 12bit pixel data into 10bit values:
 - 1 LSB ADC output precision in low light area
 - In upper region, granularity gradually increases to 2, 4, and 8 LSBs as shown

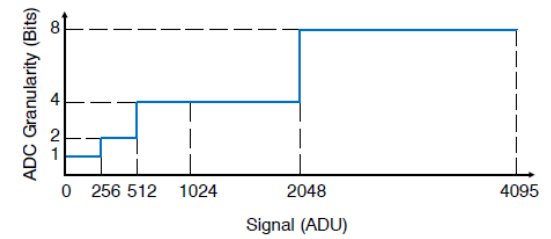

- ADC quantization steps will **always be less than the photon shot noise performance of the pixel (!)**
- Example:** Frame rate XGS 12000 low speed changes from 28 to 30+ fps with companding -> full USB3.0 bandwidth @ low power/cost

Overview assumes 12-bit sensor output (no companding), 8-bit mono pixel code on camera i/f
 With companding ON, XGS 12000 low speed (and power) equals 30 fps -> full USB3.0 bandwidth

Public Information



XGS: Power optimized speed grades tailored to camera i/f

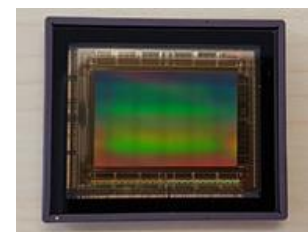
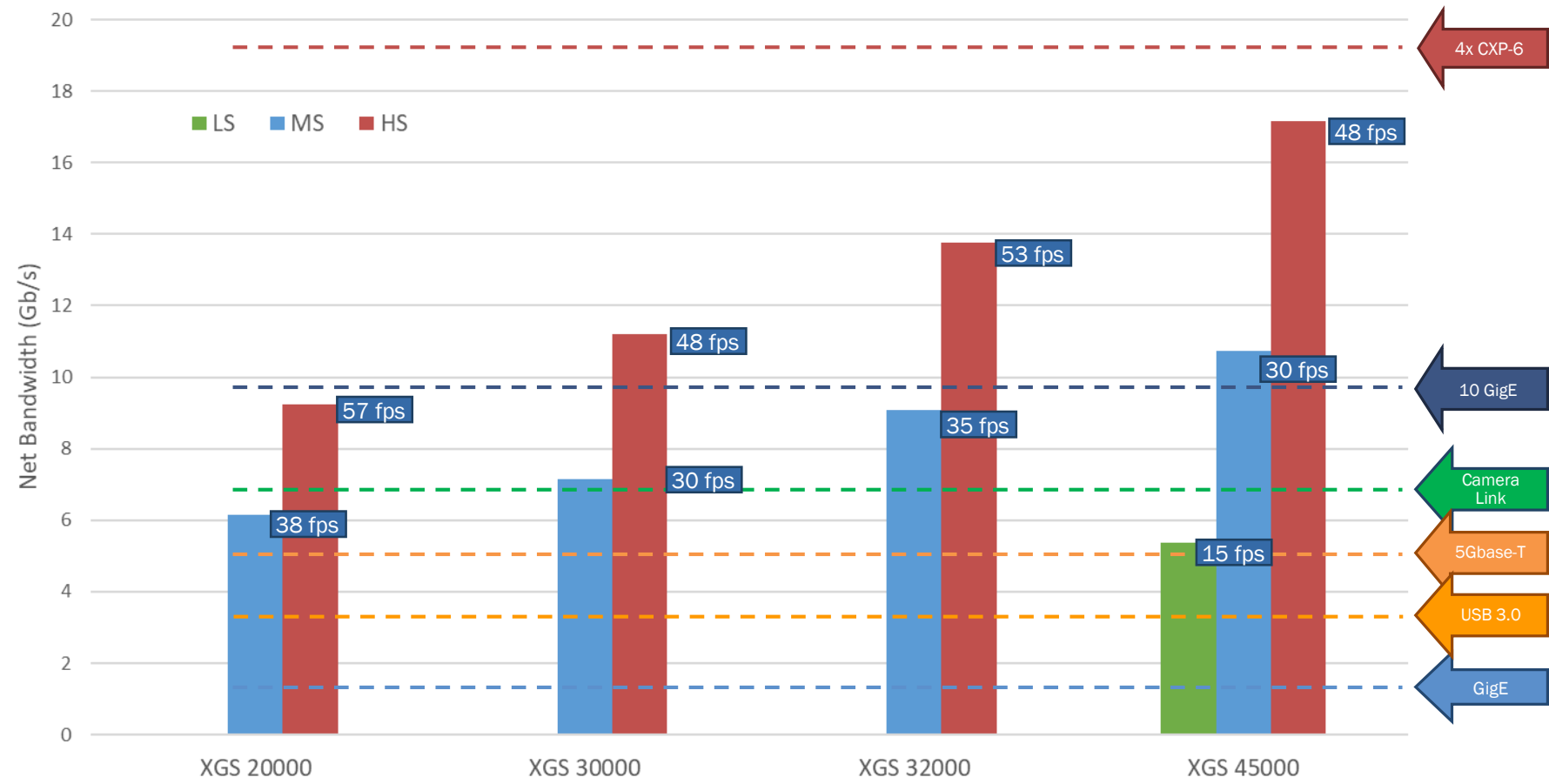

XGS 45000

XGS 30MP & 45MP have faster speed grades than most other commercially available 30MP to 50MP GS sensors



XGS Platform Comparison

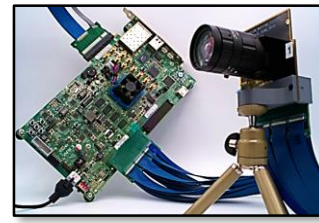

	Demo Kit	X-Celerator	X-Cube
Target	Customer/Conference Demo IQ benchmarking	FPGA Development Ecosystem (Distributors)	Access Existing MIPI ISP systems
Sensor + Lens Mount	Large	Large	Small
Power System in Headboard?	No	Yes	Yes
FPGA in Camera Head?	No	No	Yes (HiSPi -> MIPI)
Enabled System Speed (fps)	High Capture (Max fps) Lower Display (<30 fps)	High (Max fps)	Medium (30 fps)
Intermediate HW	FrameBuffer Board + Demo3	FPGA Development Kit	IAS Board + Demo3 Board
PC Communication	USB3	User Defined	USB3
Software	DevWare Only	Customer	Customer or DevWare
Public Algorithm Code	No	Yes	No
Cost (ASP)	Headboard: \$650 + FrameBuffer Board: \$2000 + Demo3 Board: \$650	Headboard: \$675 + FPGA Dev Kit: \$1k->\$4k	MIPI output X-Cube: \$675 + IAS Adapter Board: \$75 + Demo3 Board: \$650



Device Configurations and Ordering Information

	Device	CRA	LVDS Lanes	Frame Rate (12-bit)	CFA	Production OPN (MOQ = 4)
XGS 45000	XGS 45000 (8192 x 5460)	10	48	48	Color	NOIX0SE045KB-GTI
					Mono	NOIX0SN045KB-GTI
			24	31	Color	NOIX1SE045KB-GTI
					Mono	NOIX1SN045KB-GTI
			12	12	Color	NOIX2SE045KB-GTI
					Mono	NOIX2SN045KB-GTI
XGS 32000	XGS 32000 (6580 x 4935)	10	48	53	Color	NOIX0SE032KB-GTI
					Mono	NOIX0SN032KB-GTI
			24	35	Color	NOIX1SE032KB-GTI
					Mono	NOIX1SN032KB-GTI
XGS 30000	XGS 30000 (5460 x 5460)	10	48	48	Color	NOIX0SE030KB-GTI
					Mono	NOIX0SN030KB-GTI
			24	31	Color	NOIX1SE030KB-GTI
					Mono	NOIX1SN030KB-GTI
XGS 20000	XGS 20000 (4500 x 4500)	10	48	58	Color	NOIX0SE020KB-GTI
					Mono	NOIX0SN020KB-GTI
			24	38	Color	NOIX1SE020KB-GTI
					Mono	NOIX1SN020KB-GTI



Device Configurations and Ordering Information

XGS
16000

Device	CRA	LVDS Lanes	Frame Rate (12-bit)	CFA	Production OPN (MOQ = 25)	Sampling OPN (MOQ= 4)
XGS 16000 (4000 x 4000)	0	24	65	Color	NOIX1SE016KB-LTI	NOIX1SE016KB-LTI1
				Mono	NOIX1SN016KB-LTI	NOIX1SN016KB-LTI1
		12	42	Color	NOIX2SE016KB-LTI	NOIX2SE016KB-LTI1
				Mono	NOIX2SN016KB-LTI	NOIX2SN016KB-LTI1
		6	21	Color	NOIX3SE016KB-LTI	NOIX3SE016KB-LTI1
				Mono	NOIX3SN016KB-LTI	NOIX3SN016KB-LTI1



Device Configurations and Ordering Information



XGS 12000

Device	CRA	LVDS Lanes	Frame Rate (12-bit)	CFA	Production OPN (MOQ = 25)	Sampling OPN (MOQ= 4)
XGS 12000 (4096 x 3072)	0	24	90	Color	NOIX1SE012KB-LTI	NOIX1SE012KB-LTI1
				Mono	NOIX1SN012KB-LTI	NOIX1SN012KB-LTI1
	6	27	Color	NOIX3SE012KB-LTI	NOIX3SE012KB-LTI1	
			Mono	NOIX3SN012KB-LTI	NOIX3SN012KB-LTI1	
	7.3	24	90	Color	NOIX1SF012KB-LTI	NOIX1SF012KB-LTI1



XGS 9400

XGS 9400 (3072 x 3072)	0	24	90	Color	NOIX1SE9400B-LTI	NOIX1SE9400B-LTI1
				Mono	NOIX1SN9400B-LTI	NOIX1SN9400B-LTI1
	12	45	Color	NOIX2SE9400B-LTI	NOIX2SE9400B-LTI1	
			Mono	NOIX2SN9400B-LTI	NOIX2SN9400B-LTI1	



XGS 8000

XGS 8000 (4096 x 2160)	0	24	128	Color	NOIX1SE8000B-LTI	NOIX1SE8000B-LTI1
				Mono	NOIX1SN8000B-LTI	NOIX1SN8000B-LTI1
	12	75	Color	NOIX2SE8000B-LTI	NOIX2SE8000B-LTI1	
			Mono	NOIX2SN8000B-LTI	NOIX2SN8000B-LTI1	
	7.3	12	75	Color	NOIX2SF8000B-LTI	NOIX2SF8000B-LTI1



Device Configurations and Ordering Information

XGS 5000

Device	CRA	LVDS Lanes	Frame Rate (12-bit)	CFA	Production OPN (MOQ = 25)	Sampling OPN (MOQ= 4)
XGS 5000 (2592 x 2048)	0	16	132	Color	NOIX4SE5000B-LTI	NOIX4SE5000B-LTI1
				Mono	NOIX4SN5000B-LTI	NOIX4SN5000B-LTI1
	4	43	Color	NOIX5SE5000B-LTI	NOIX5SE5000B-LTI1	
			Mono	NOIX5SN5000B-LTI	NOIX5SN5000B-LTI1	
	4.7	16	132	Color	NOIX4SF5000B-LTI	NOIX4SF5000B-LTI1

XGS 3000

XGS 3000 (2048 x 1538)	4.7	16	175	Color	NOIX4SF3000B-LTI	NOIX4SF3000B-LTI1
				Mono	NOIX4SP3000B-LTI	NOIX4SP3000B-LTI1

XGS 2000

XGS 2000 (1920 x 1200)	0	16	220	Color	NOIX4SE2000B-LTI	NOIX4SE2000B-LTI1
				Mono	NOIX4SN2000B-LTI	NOIX4SN2000B-LTI1

