

LMV321, LMV358, LMV324

General Purpose, Low Voltage, Rail-to-Rail Output Amplifiers

Features at +2.7V

- 80µA supply current per channel
- 1.2MHz gain bandwidth product
- Output voltage range: 0.01V to 2.69V
- Input voltage range: -0.25V to +1.5V
- 1.5V/µs slew rate
- LMV321 directly replaces other industry standard LMV321 amplifiers; available in SC70-5 and SOT23-5 packages
- LMV358 directly replaces other industry standard LMV358 amplifiers; available in MSOP-8 and SOIC-8 packages
- LMV324 directly replaces other industry standard LMV324 amplifiers; available in SOIC-14 package
- Fully specified at +2.7V and +5V supplies
- Operating temperature range: -40°C to +125°C

Applications

- Low cost general purpose applications
- Cellular phones
- Personal data assistants
- A/D buffer
- DSP interface
- Smart card readers
- Portable test instruments
- Keyless entry
- Infrared receivers for remote controls
- Telephone systems
- Audio applications
- Digital still cameras
- Hard disk drives
- MP3 players

Description

The LMV321 (single), LMV358 (dual), and LMV324 (quad) are a low cost, voltage feedback amplifiers that consume only 80µA of supply current per amplifier. The LMV3XX family is designed to operate from 2.7V (±1.35V) to 5.5V (±2.75V) supplies. The common mode voltage range extends below the negative rail and the output provides rail-to-rail performance.

The LMV3XX family is designed on a CMOS process and provides 1.2MHz of bandwidth and 1.5V/µs of slew rate at a low supply voltage of 2.7V. The combination of low power, rail-to-rail performance, low voltage operation, and tiny package options make the LMV3XX family well suited for use in personal electronics equipment such as cellular handsets, pagers, PDAs, and other battery powered applications.

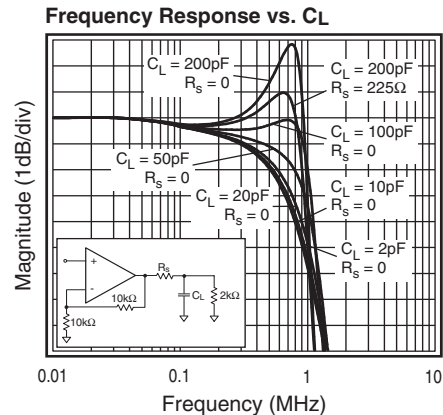

Typical Application

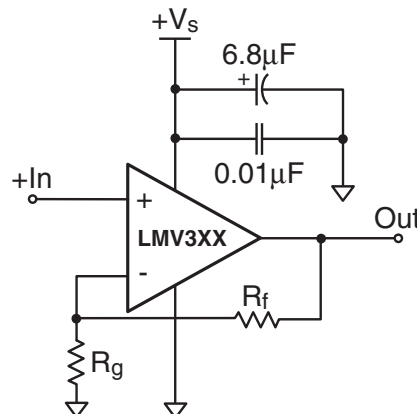

Pin Assignments

LMV321

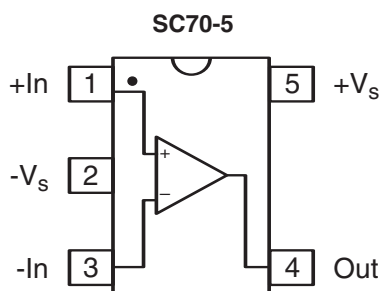
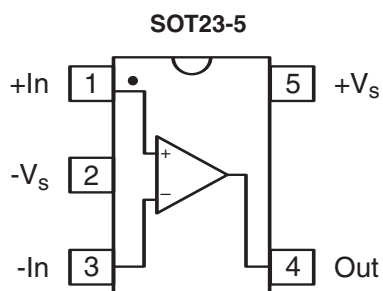

LMV358

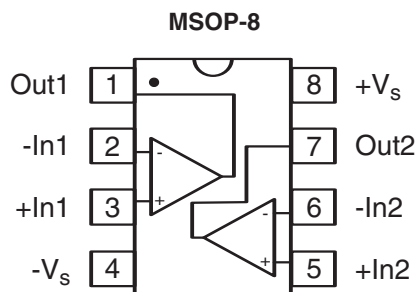
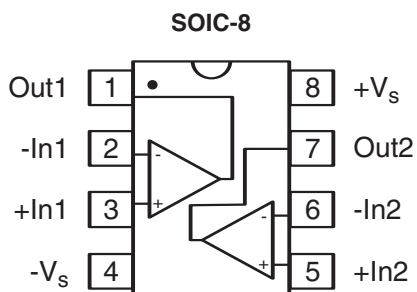

LMV324

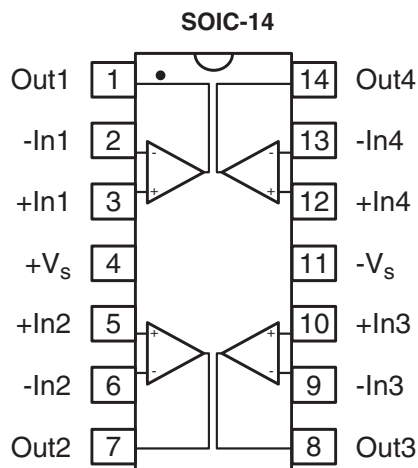
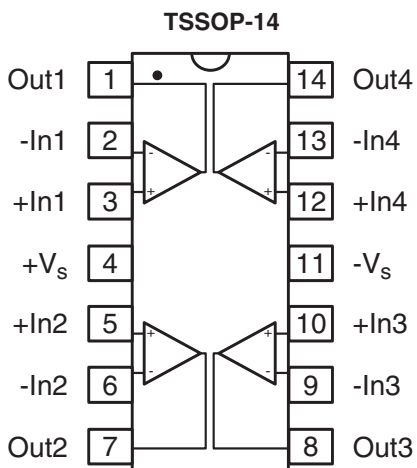

Absolute Maximum Ratings

Parameter	Min.	Max.	Unit
Supply Voltages	0	+6	V
Maximum Junction Temperature	–	+175	°C
Storage Temperature Range	-65	+150	°C
Lead Temperature, 10 seconds	–	+260	°C
Input Voltage Range	-V _S -0.5	+V _S +0.5	V

Recommended Operating Conditions

Parameter	Min.	Max.	Unit
Operating Temperature Range	-40	+125	°C
Power Supply Operating Range	2.5	5.5	V

Electrical Specifications

(T_C = 25°C, V_S = +2.7V, G = 2, R_L = 10kΩ to V_S/2, R_f = 10kΩ, V_O (DC) = V_{CC}/2; unless otherwise noted)

Parameter	Conditions	Min.	Typ.	Max.	Unit
AC Performance					
Gain Bandwidth Product	C _L = 50pF, R _L = 2kΩ to V _S /2		1.2		MHz
Phase Margin			52		deg
Gain Margin			17		dB
Slew Rate	V _O = 1V _{pp}		1.5		V/μs
Input Voltage Noise	>50kHz		36		nV/√Hz
Crosstalk: LMV358	100kHz		91		dB
LMV324	100kHz		80		dB
DC Performance					
Input Offset Voltage ¹			1.7	7	mV
Average Drift			8		μV/°C
Input Bias Current ²			<1		nA
Input Offset Current ²			<1		nA
Power Supply Rejection Ratio ¹	DC	50	65		dB
Supply Current (Per Channel) ¹			80	120	μA
Input Characteristics					
Input Common Mode Voltage Range ¹	LO	0	-0.25		V
	HI		1.5	1.3	V
Common Mode Rejection Ratio ¹		50	70		dB
Output Characteristics					
Output Voltage Swing	R _L = 10kΩ to V _S /2; LO ¹	0.1	0.01		V
	R _L = 10kΩ to V _S /2; HI ¹		2.69	2.6	V

Min/max ratings are based on product characterization and simulation. Individual parameters are tested as noted. Outgoing quality levels are determined from tested parameters.

Notes:

- Guaranteed by testing or statistical analysis at +25°C.
- +IN and -IN are gates to CMOS transistors with typical input bias current of <1nA. CMOS leakage is too small to practically measure.

Electrical Specifications

($T_C = 25^\circ\text{C}$, $V_S = +5\text{V}$, $G = 2$, $R_L = 10\text{k}\Omega$ to $V_S/2$, $R_f = 10\text{k}\Omega$, $V_O(\text{DC}) = V_{CC}/2$; unless otherwise noted)

Parameter	Conditions	Min.	Typ.	Max.	Unit
AC Performance					
Gain Bandwidth Product	$C_L = 50\text{pF}$, $R_L = 2\text{k}\Omega$ to $V_S/2$		1.4		MHz
Phase Margin			73		deg
Gain Margin			12		dB
Slew Rate			1.5		$\text{V}/\mu\text{s}$
Input Voltage Noise	$>50\text{kHz}$		33		$\text{nV}/\sqrt{\text{Hz}}$
Crosstalk: LMV358	100kHz		91		dB
LMV324	100kHz		80		dB
DC Performance					
Input Offset Voltage ¹			1	7	mV
Average Drift			6		$\mu\text{V}/^\circ\text{C}$
Input Bias Current ²			<1		nA
Input Offset Current ²			<1		nA
Power Supply Rejection Ratio ¹	DC	50	65		dB
Open Loop Gain ¹		50	70		dB
Supply Current (Per Channel) ¹			100	150	μA
Input Characteristics					
Input Common Mode Voltage Range ¹	LO	0	-0.4		V
	HI		3.8	3.6	V
Common Mode Rejection Ratio ¹		50	75		dB
Output Characteristics					
Output Voltage Swing	$R_L = 2\text{k}\Omega$ to $V_S/2$; LO/HI		0.036 to 4.95		V
	$R_L = 10\text{k}\Omega$ to $V_S/2$; LO ¹	0.1	0.013		V
	$R_L = 10\text{k}\Omega$ to $V_S/2$; HI ¹		4.98	4.9	V
Short Circuit Output Current ¹	sourcing; $V_O = 0\text{V}$	5	+34		mA
	sinking; $V_O = 5\text{V}$	10	-23		mA

Min/max ratings are based on product characterization and simulation. Individual parameters are tested as noted. Outgoing quality levels are determined from tested parameters.

Notes:

- Guaranteed by testing or statistical analysis at $+25^\circ\text{C}$.
- +IN and -IN are gates to CMOS transistors with typical input bias current of $<1\text{nA}$. CMOS leakage is too small to practically measure.

Package Thermal Resistance

Package	θ_{JA}
5 lead SC70	331.4°C/W
5 lead SOT23	256°C/W
8 lead SOIC	152°C/W
8 lead MSOP	206°C/W
14 lead SOIC	88°C/W

Typical Operating Characteristics

($T_C = 25^\circ\text{C}$, $V_S = +5\text{V}$, $G = 2$, $R_L = 10\text{k}\Omega$ to $V_S/2$, $R_f = 10\text{k}\Omega$, $V_O(\text{DC}) = V_{CC}/2$; unless otherwise noted)

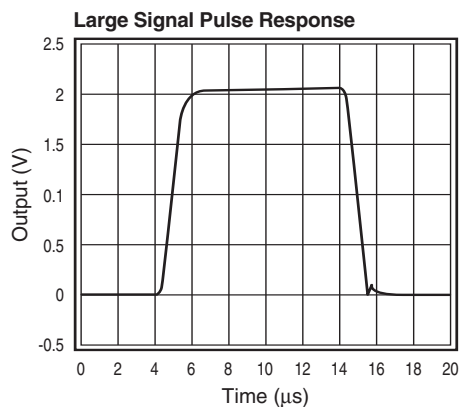
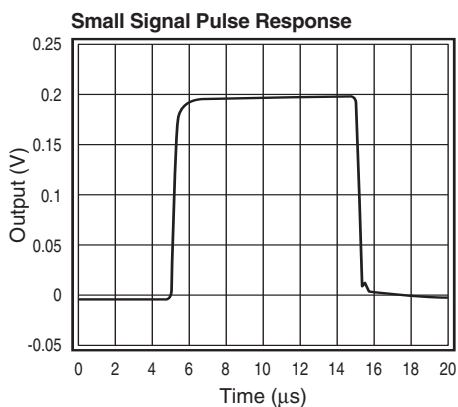
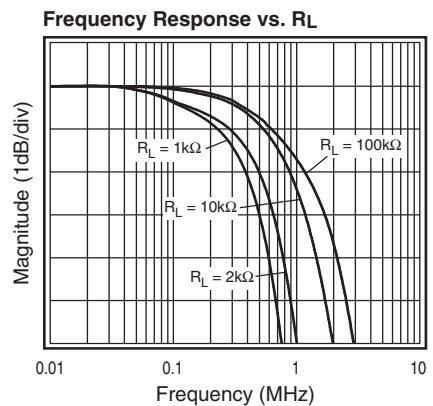
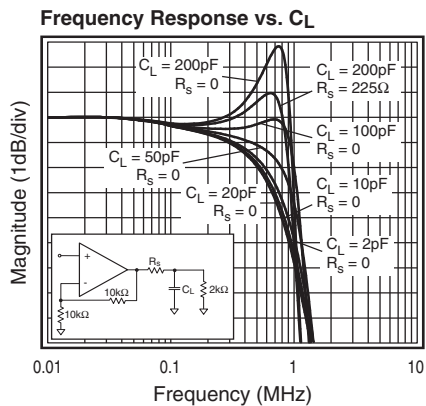
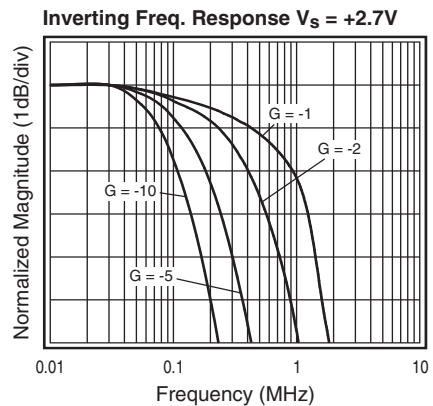
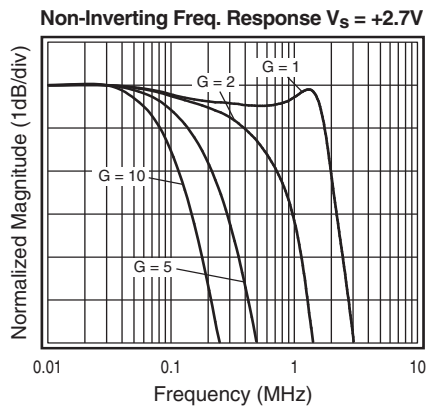
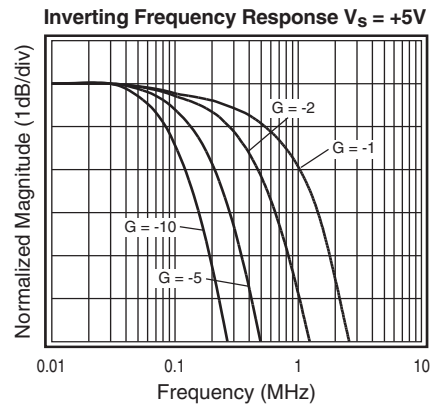
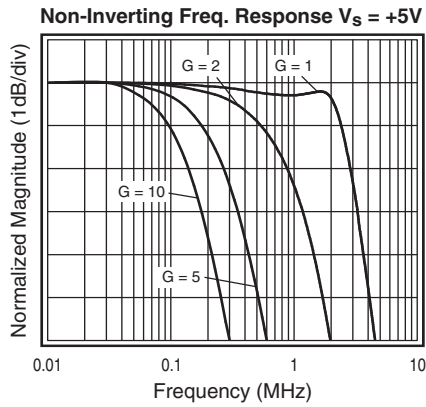

Typical Operating Characteristics

($T_C = 25^\circ\text{C}$, $V_S = +5\text{V}$, $G = 2$, $R_L = 10\text{k}\Omega$ to $V_S/2$, $R_f = 10\text{k}\Omega$, $V_o(\text{DC}) = V_{CC}/2$; unless otherwise noted)

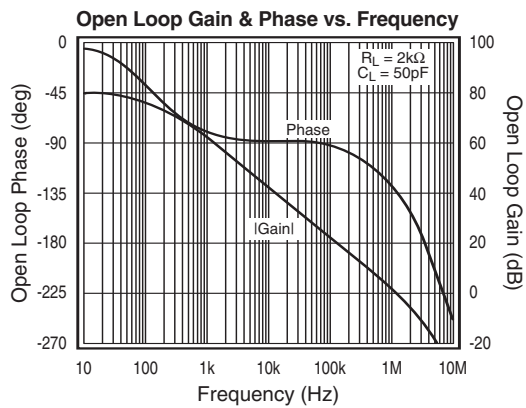
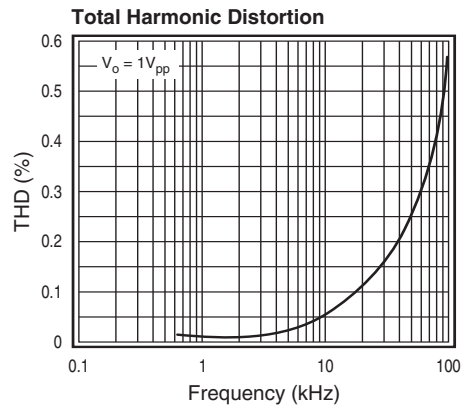
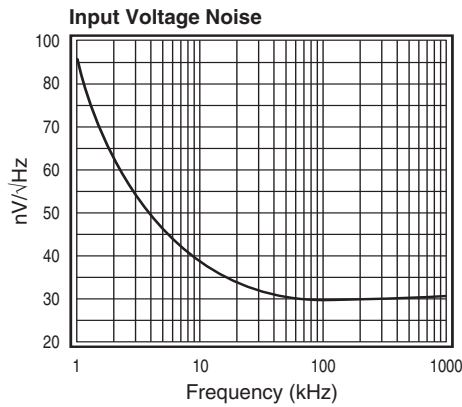

Application Information

General Description

The LMV3XX family are dual supply, general purpose, voltage-feedback amplifiers that are pin-for-pin compatible and drop in replacements with other industry standard LMV321, LMV358, and LMV324 amplifiers. The LMV3XX family is fabricated on a CMOS process, features a rail-to-rail output, and is unity gain stable.

The typical non-inverting circuit schematic is shown in Figure

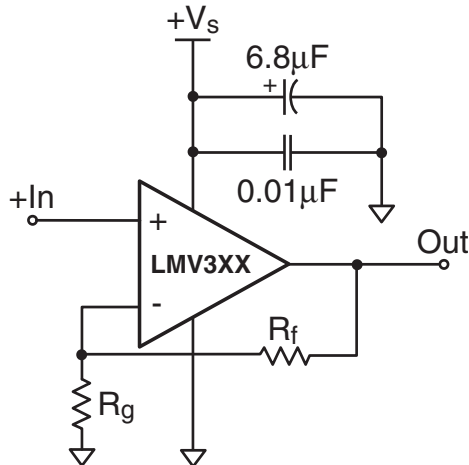

1. **Figure 1: Typical Non-inverting configuration**

Power Dissipation

The maximum internal power dissipation allowed is directly related to the maximum junction temperature. If the maximum junction temperature exceeds 150°C, some performance degradation will occur. If the maximum junction temperature exceeds 175°C for an extended time, device failure may occur.

Driving Capacitive Loads

The *Frequency Response vs C_L* plot on page 4, illustrates the response of the LMV3XX family. A small series resistance (R_s) at the output of the amplifier, illustrated in Figure 2, will improve stability and settling performance. R_s values in the *Frequency Response vs C_L* plot were chosen to achieve maximum bandwidth with less than 1dB of peaking. For maximum flatness, use a larger R_s . As the plot indicates, the LMV3XX family can easily drive a 200pF capacitive load without a series resistance. For comparison, the plot also shows the LMV321 driving a 200pF load with a 225Ω series resistance.

Driving a capacitive load introduces phase-lag into the output signal, which reduces phase margin in the amplifier. The unity gain follower is the most sensitive configuration. In a unity gain follower configuration, the LMV3XX family requires a 450Ω series resistor to drive a 200pF load. The response is illustrated in Figure 3.

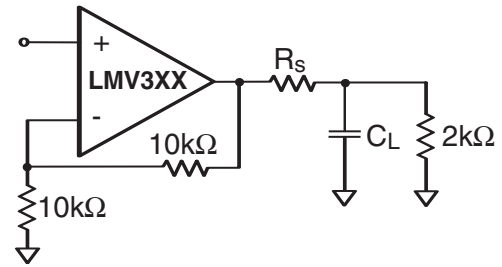

Figure 2: Typical Topology for driving a capacitive load

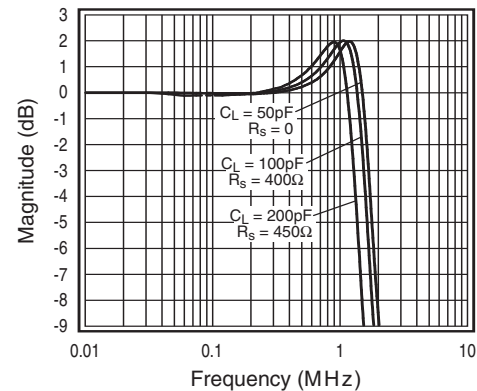

Figure 3: Frequency Response vs C_L for unity gain configuration

Layout Considerations

General layout and supply bypassing play major roles in high frequency performance. Fairchild has evaluation boards to use as a guide for high frequency layout and as aid in device testing and characterization. Follow the steps below as a basis for high frequency layout:

- Include 6.8µF and 0.01µF ceramic capacitors
- Place the 6.8µF capacitor within 0.75 inches of the power pin
- Place the 0.01µF capacitor within 0.1 inches of the power pin
- Remove the ground plane under and around the part, especially near the input and output pins to reduce parasitic capacitance
- Minimize all trace lengths to reduce series inductances

Refer to the evaluation board layouts shown in Figure 5 on page 8 for more information.

Evaluation Board Information

The following evaluation boards are available to aid in the testing and layout of this device:

Evaluation board schematics and layouts are shown in Figures 4 and 5.

Eval Bd	Description	Products
KEB013	Single Channel, Dual Supply, SOT23-5 for buffer-style pinout	LMV321AS5X
KEB014	Single Channel, Dual Supply, SC70-5 for buffer-style pinout	LMV321AP5X
KEB006	Dual Channel, Dual Supply, 8 lead SOIC	LMV358AM8X
KEB010	Dual Channel, Dual Supply, 8 lead MSOP	LMV358AMU8X
KEB018	Quad Channel, Dual Supply, 14 lead SOIC	LMV324AM14X

Evaluation Board Schematic Diagrams

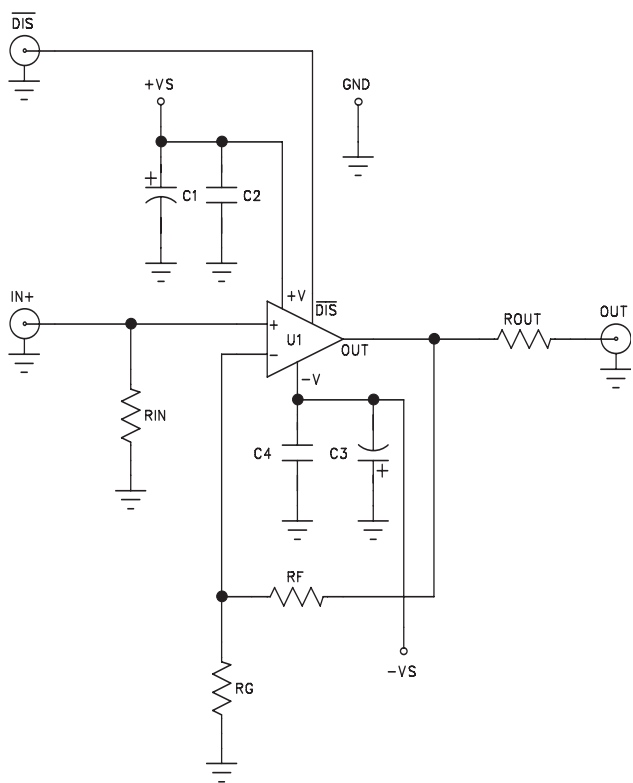

Figure 4a: LMV321 KEB013 schematic

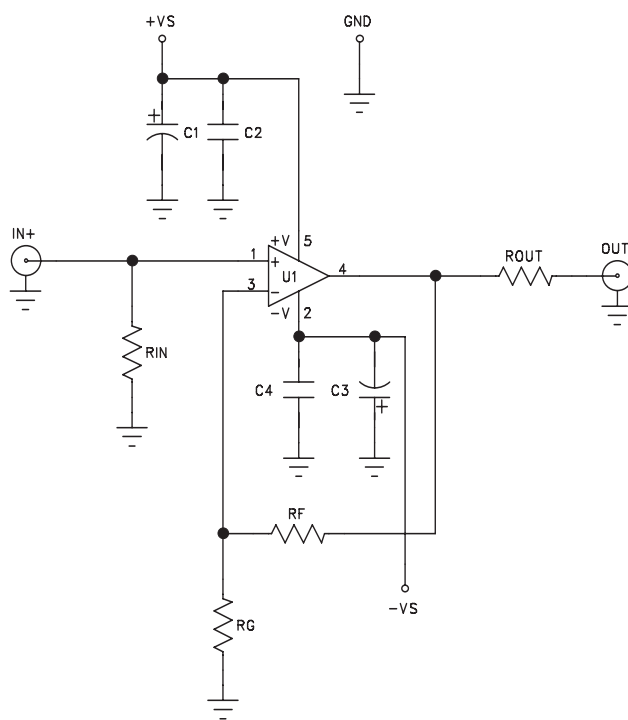

Figure 4b: LMV321 KEB014 schematic

Evaluation Board Schematic Diagrams (Continued)

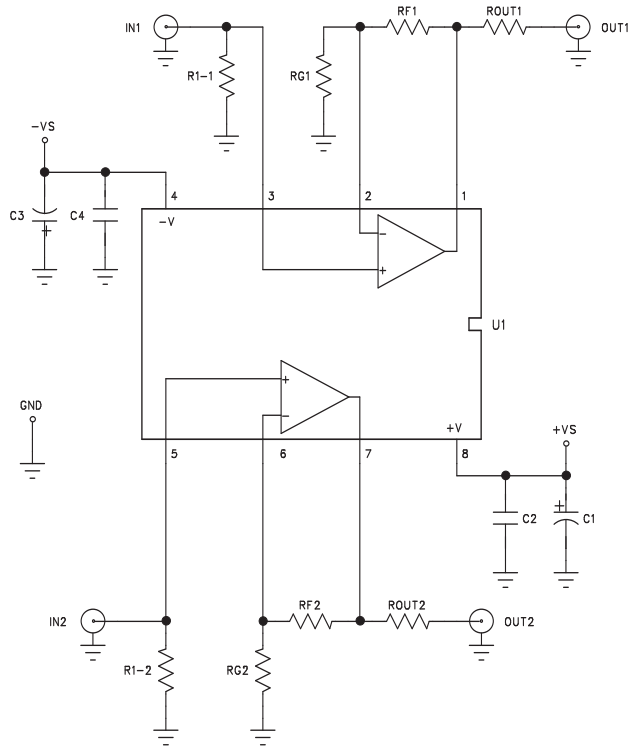
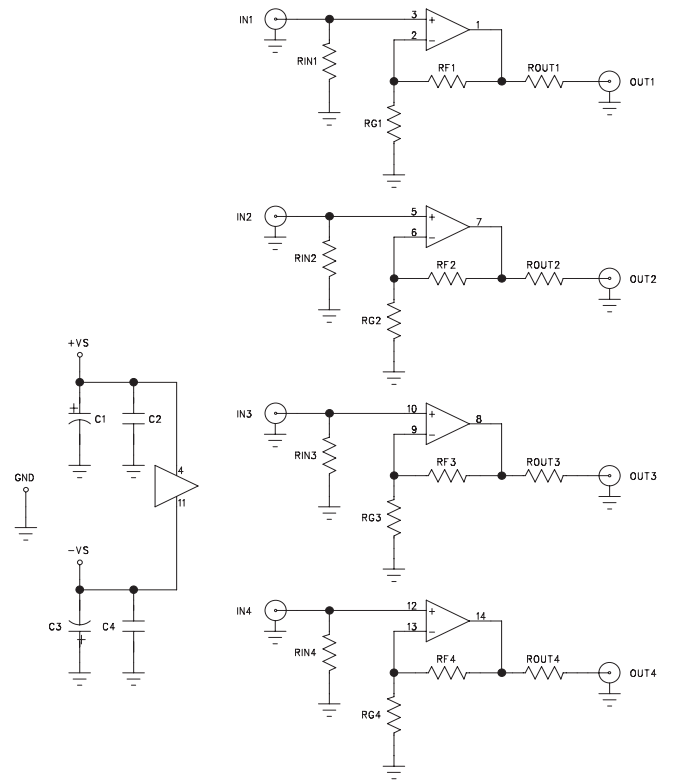

Figure 4c: LMV358 KEB006/KEB010 schematic



BOARD MOUNTING HOLES

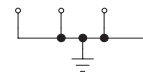

Figure 4d: LMV324 KEB012/KEB018 schematic

LMV321 Evaluation Board Layout

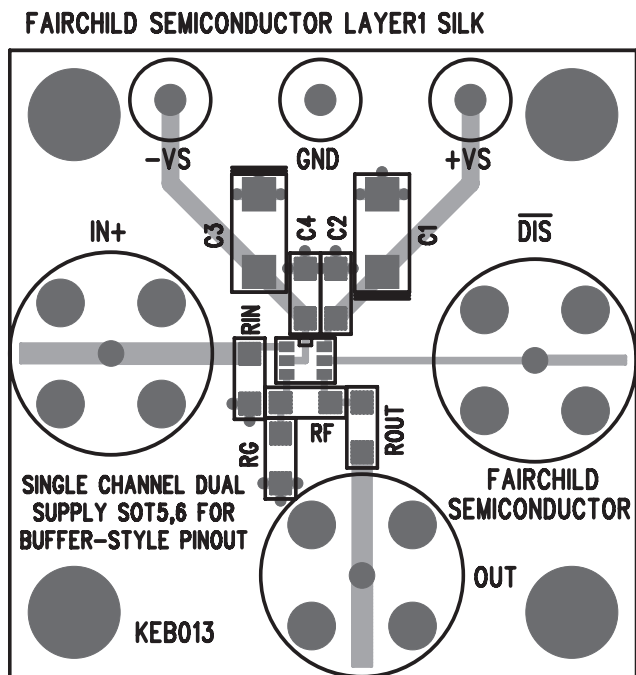

Figure 5a: KEB013 (top side)

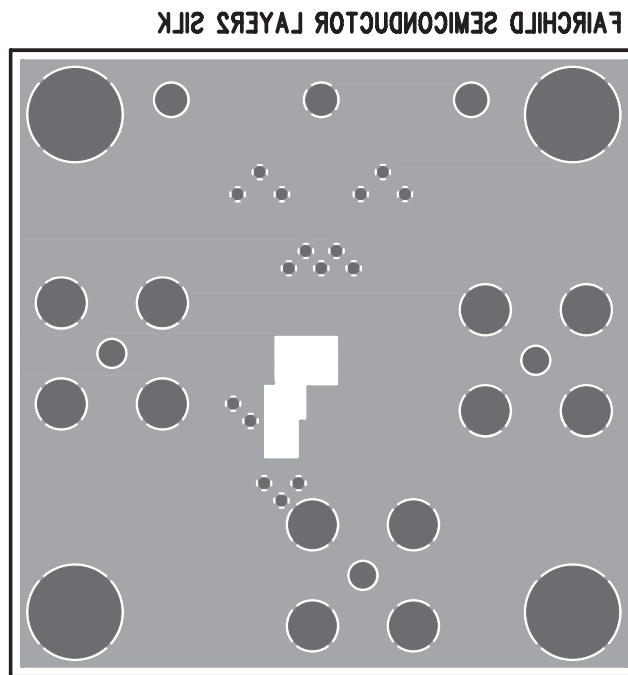

Figure 5b: KEB013 (bottom side)

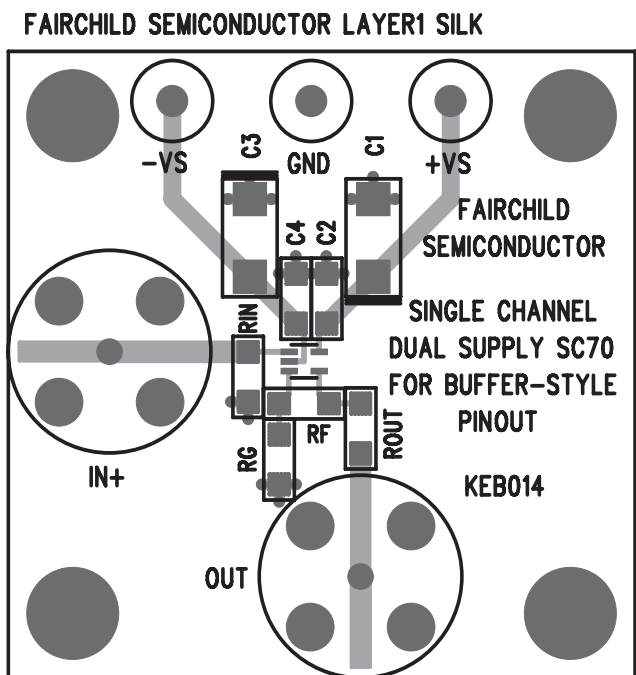

Figure 5c: KEB014 (top side)

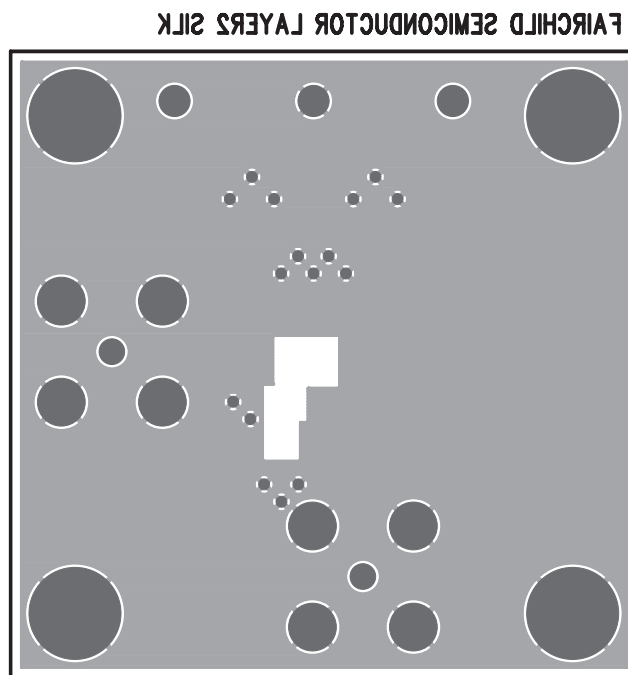

Figure 5d: KEB014 (bottom side)

LMV358 Evaluation Board Layout

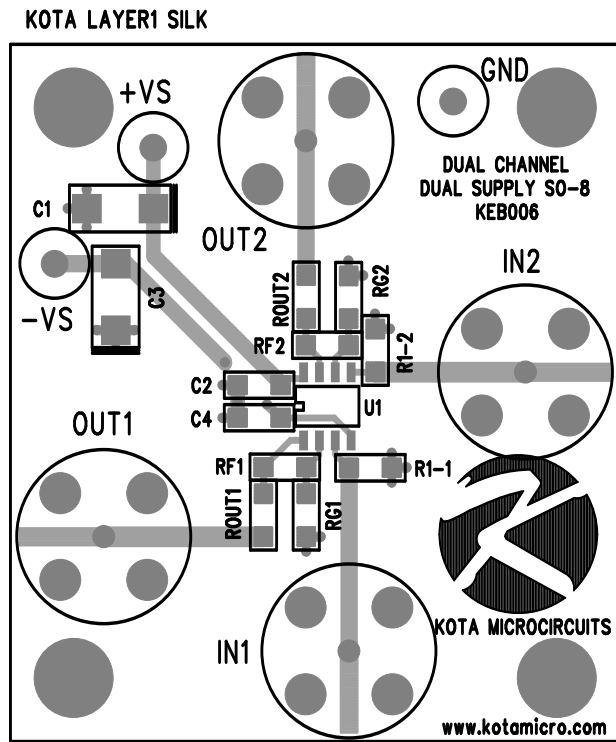

Figure 5e: KEB006 (top side)

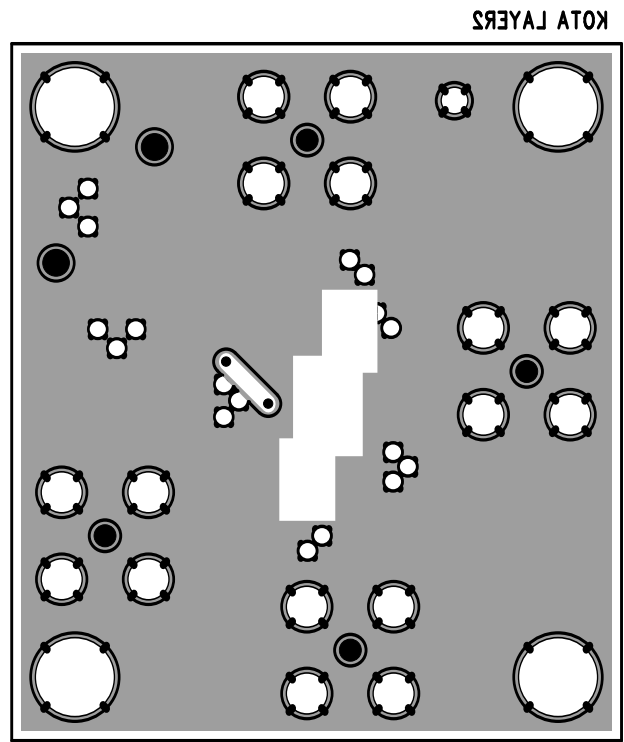

Figure 5f: KEB006 (bottom side)

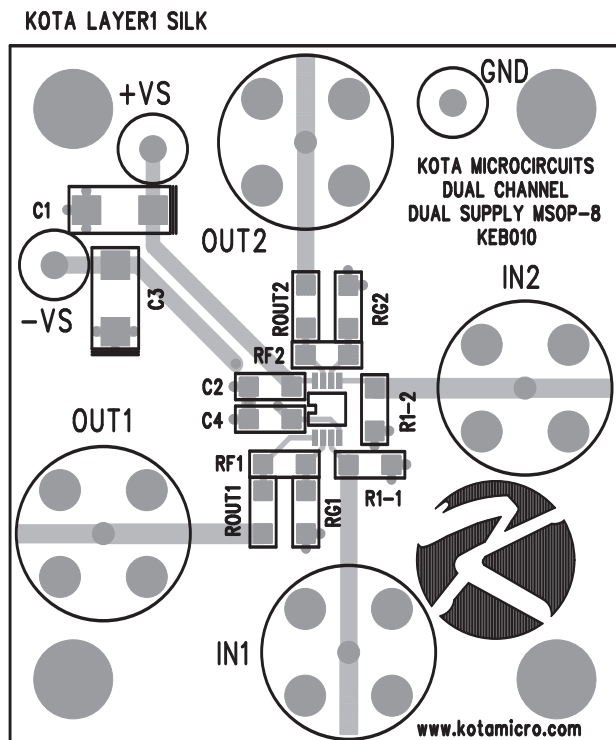

Figure 5g: KEB010 (top side)

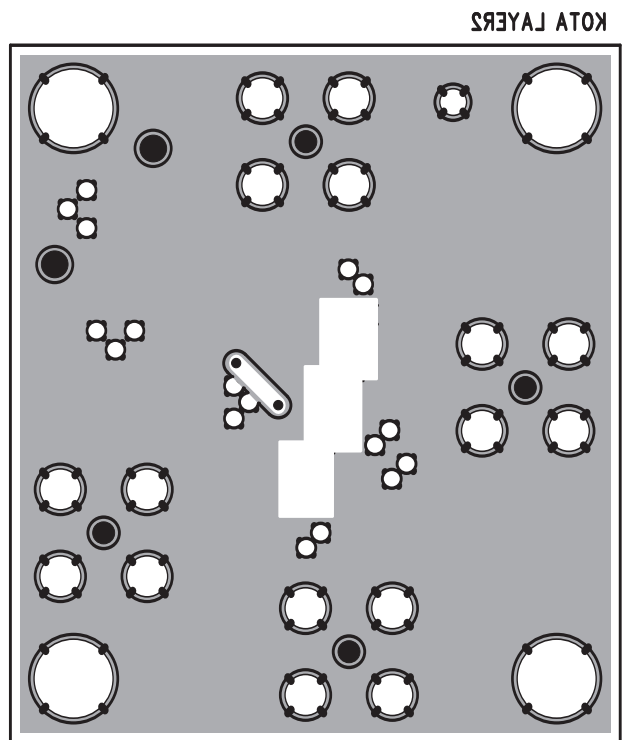

Figure 5h: KEB010 (bottom side)

LMV324 Evaluation Board Layout

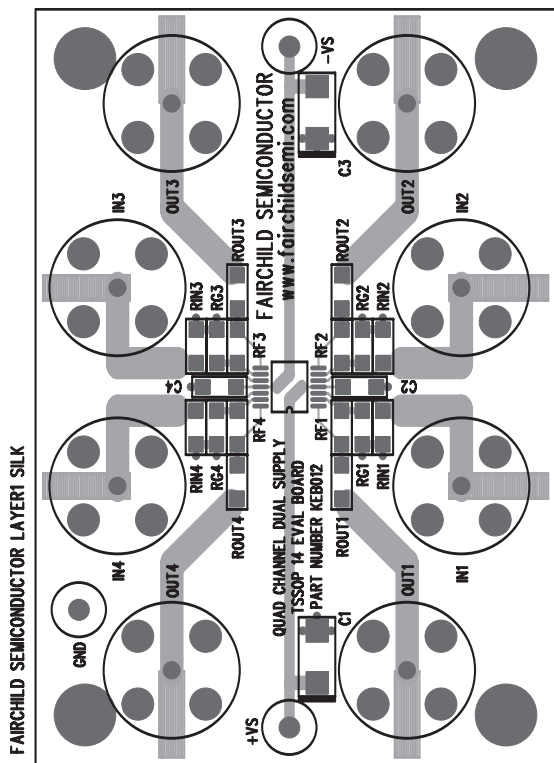

Figure 5i: KEB012 (top side)

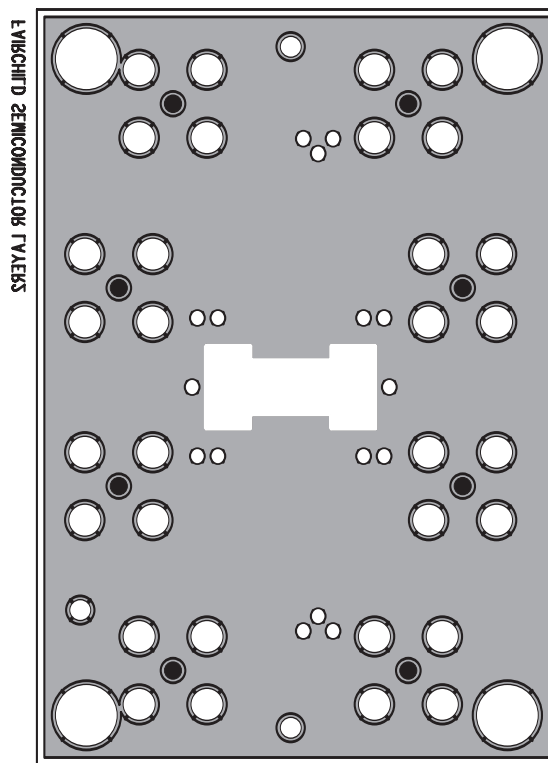

Figure 5j: KEB012 (bottom side)

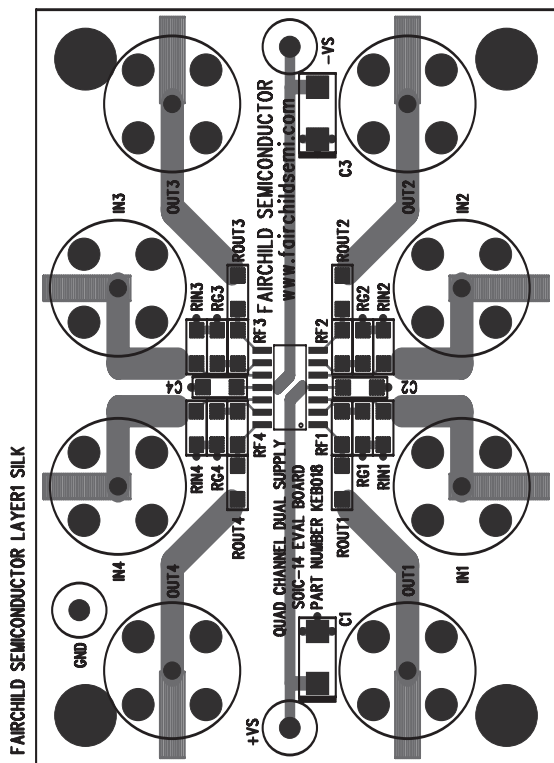

Figure 5k: KEB018 (top side)

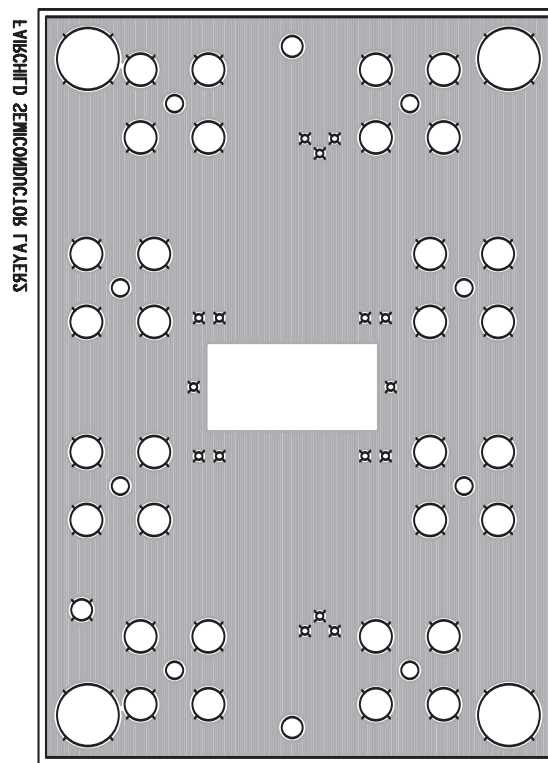
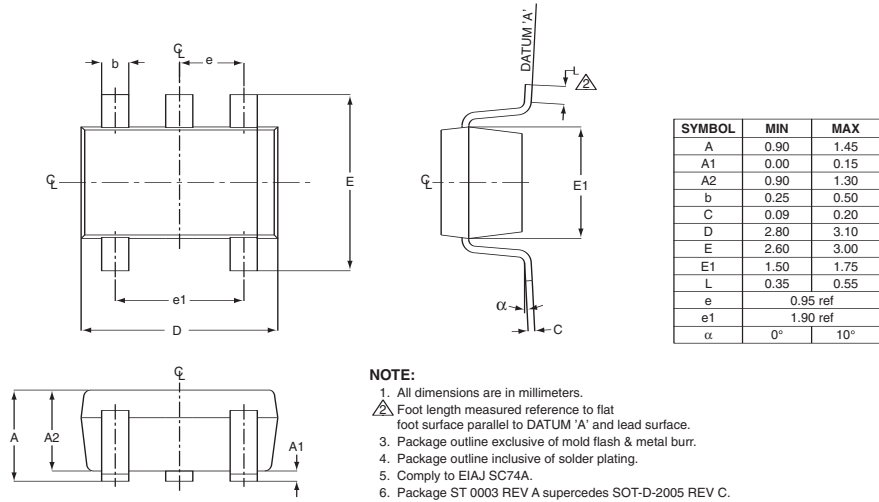

Figure 5l: KEB018 (bottom side)

LMV321 Package Dimensions

SOT23-5



SC70

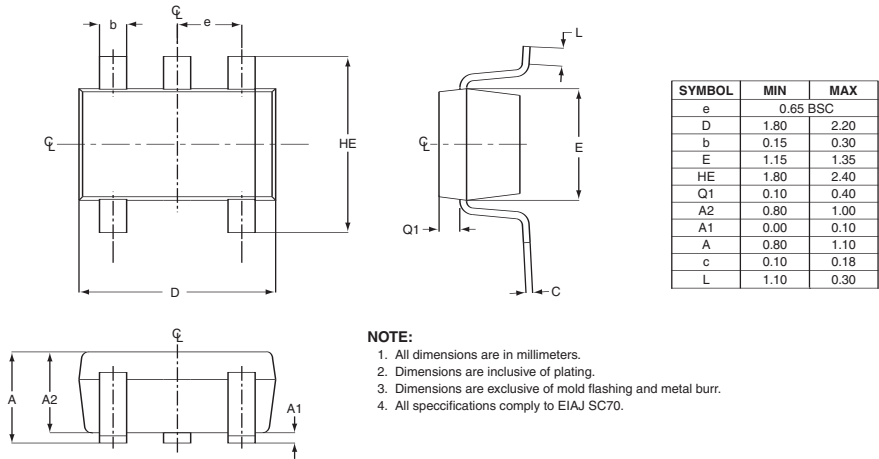

LMV358 Package Dimensions

SOIC

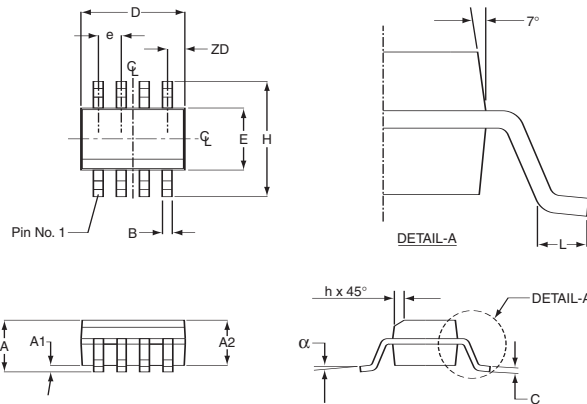

SOIC-8		
SYMBOL	MIN	MAX
A1	0.10	0.25
B	0.36	0.46
C	0.19	0.25
D	4.80	4.98
E	3.81	3.99
e	1.27 BSC	
H	5.80	6.20
h	0.25	0.50
L	0.41	1.27
A	1.52	1.72
	0°	8°
ZD	0.53 ref	
A2	1.37	1.57

NOTE:

1. All dimensions are in millimeters.
2. Lead coplanarity should be 0 to 0.10mm (.004") max.
3. Package surface finishing:
 (2.1) Top: matte (charmilles #18-30).
 (2.2) All sides: matte (charmilles #18-30).
 (2.3) Bottom: smooth or matte (charmilles #18-30).
4. All dimensions excluding mold flashes and end flash from the package body shall not exceed 0.152mm (.006) per side(d).

MSOP

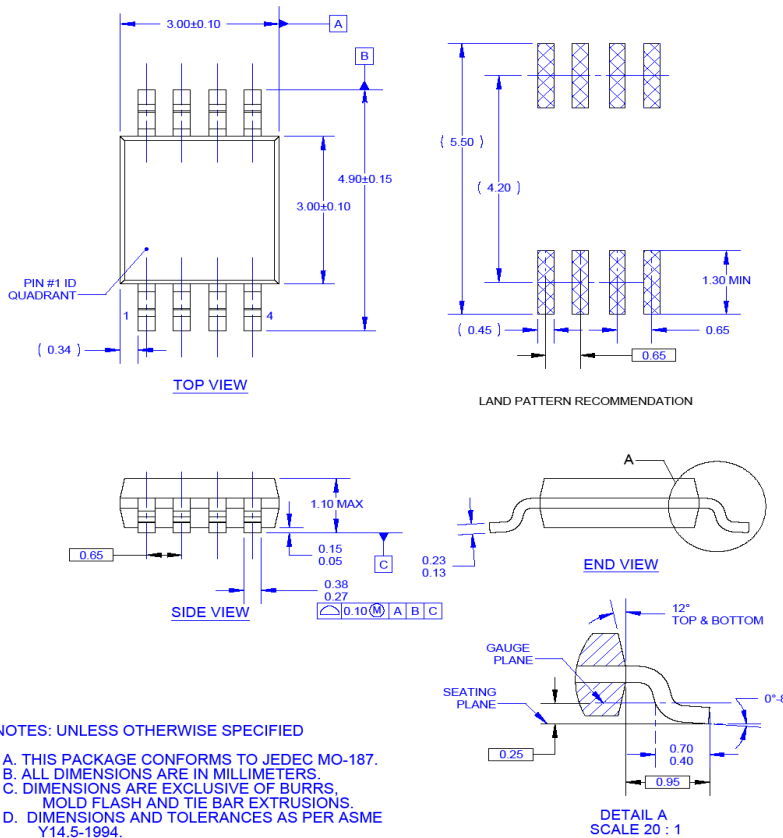

NOTES: UNLESS OTHERWISE SPECIFIED

- A. THIS PACKAGE CONFORMS TO JEDEC MO-187.
- B. ALL DIMENSIONS ARE IN MILLIMETERS.
- C. DIMENSIONS ARE EXCLUSIVE OF BURRS, MOLD FLASH AND TIE BAR EXTRUSIONS.
- D. DIMENSIONS AND TOLERANCES AS PER ASME Y14.5-1994.
- E. LAND PATTERN AS PER IPC7351#TSOP65P490X110-8BL
- F. FILE NAME: MKT-MUA08AREV4

LMV324 Package Dimensions

SOIC

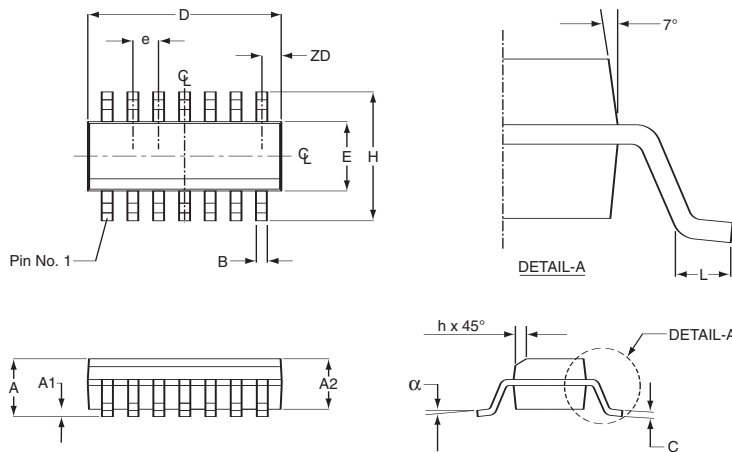

SOIC-14		
SYMBOL	MIN	MAX
A1	.0040	.0098
B	.014	.018
C	.0075	.0098
D	.337	.344
E	.150	.157
e	.050 BSC	
H	.2284	.2440
h	.0099	.0196
L	.016	.050
A	.060	.068
	0°	8°
ZD	0.020 ref	
A2	.054	.062

NOTE:

1. All dimensions are in inches.
2. Lead coplanarity should be 0 to 0.10mm (.004") max.
3. Package surface finishing:
 - (2.1) Top: matte (charmilles #18-30).
 - (2.2) All sides: matte (charmilles #18-30).
 - (2.3) Bottom: smooth or matte (charmilles #18-30).
4. All dimensions excluding mold flashes and end flash from the package body shall not exceed 0.152mm (.006) per side (d).

Ordering Information

Model	Part Number	Package	Container	Pack Qty
LMV321	LMV321AP5X	SC70-5	Reel	3000
LMV321	LMV321AS5X	SOT23-5	Reel	3000
LMV358	LMV358AM8X	SOIC-8 (Narrow)	Reel	2500
LMV358	LMV358AMU8X	MSOP-8	Reel	3000
LMV324	LMV324AM14X	SOIC-14	Reel	2500

Temperature range for all parts: -40°C to +125°C.

DISCLAIMER

FAIRCHILD SEMICONDUCTOR RESERVES THE RIGHT TO MAKE CHANGES WITHOUT FURTHER NOTICES TO ANY PRODUCTS HEREIN TO IMPROVE RELIABILITY, FUNCTION OR DESIGN. FAIRCHILD DOES NOT ASSUME ANY LIABILITY ARISING OUT OF THE APPLICATION OR USE OF ANY PRODUCT OR CIRCUIT DESCRIBED HEREIN; NEITHER DOES IT CONVEY ANY LICENSE UNDER ITS PATENT RIGHTS, NOR THE RIGHTS OF OTHERS.

LIFE SUPPORT POLICY

FAIRCHILD'S PRODUCTS ARE NOT AUTHORIZED FOR USE AS CRITICAL COMPONENTS IN LIFE SUPPORT DEVICES OR SYSTEMS WITHOUT THE EXPRESS WRITTEN APPROVAL OF THE PRESIDENT OF FAIRCHILD SEMICONDUCTOR CORPORATION. As used herein:

1. Life support devices or systems are devices or systems which, (a) are intended for surgical implant into the body, or (b) support or sustain life, and (c) whose failure to perform when properly used in accordance with instructions for use provided in the labeling, can be reasonably expected to result in a significant injury of the user.
2. A critical component in any component of a life support device or system whose failure to perform can be reasonably expected to cause the failure of the life support device or system, or to affect its safety or effectiveness.

Mouser Electronics

Authorized Distributor

Click to View Pricing, Inventory, Delivery & Lifecycle Information:

Fairchild Semiconductor:

[LMV321AS5X](#) [LMV358AMU8X](#) [LMV324AMTC14X](#) [LMV358AM8X](#) [LMV321AP5X](#) [LMV324AM14X](#) [LMV321AS5X_Q](#)
[LMV358AMU8X_Q](#) [LMV324AMTC14X_Q](#) [LMV321AP5X_Q](#)