

PRODUCT NUMBER  
SEE SHEET 3

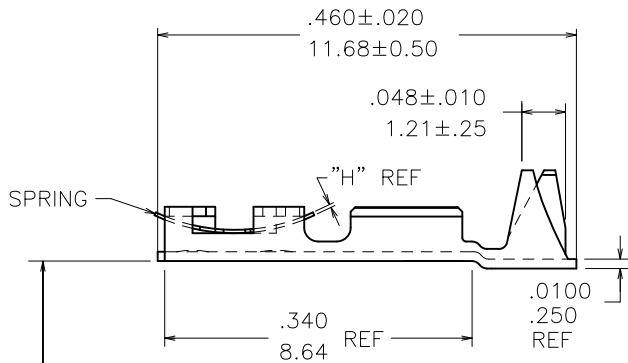
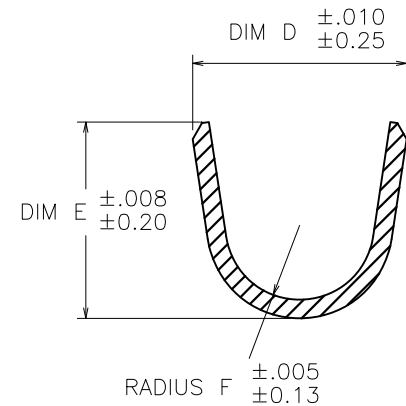
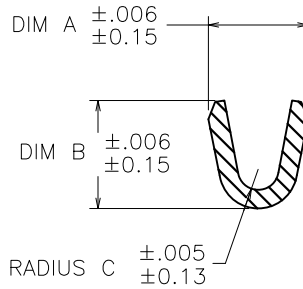
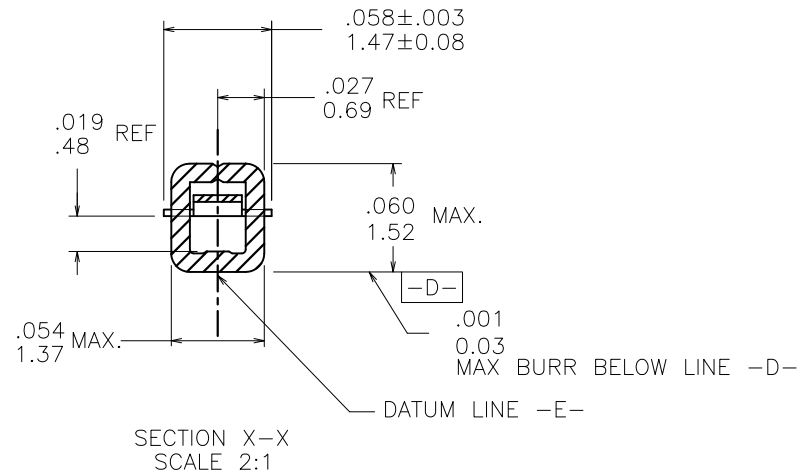
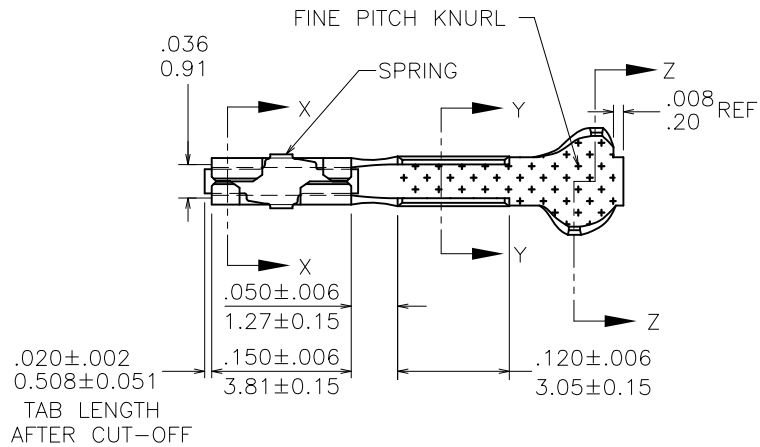

mat'l. code SEE TABLE				surface	tolerance	projection	product family PV TERMINALS
ltr	ecn no	dr	date	tolerances unless otherwise specified		INCH/MM	title
AG	v07-0218	HTB	2007-03-16	angles	linear		scale 5:1
AH	v08-0113	HTB	2008-03-28				
AJ	F08-0159	HTB	2008-04-16				sheet 1 of 6
AK	F08-0189	HTB	2008-06-25	dr	T. BREWBAKER	2006-04-18	size
AL	v08-0510	HTB	2008-12-02	engr	T. BREWBAKER	2006-04-18	A3
AM	v10-0359	HTB	2010-09-15	chr	T. BREWBAKER	2006-04-18	
				appd	T. BREWBAKER	2006-04-18	type
sheet	revision	AM	AM	AM	AM	AM	Product Customer Drawing
index	sheet	1	2	3	4	5	

PRODUCT NUMBER SEE SHEET 3	AWG	WIRE BARREL			INSULATION BARREL				RECOMMENDED HANDTOOL FOR LOOSE PIECE APPLICATION
	RANGE	DIM A	DIM B	RADIUS C	INSULATION DIAMETER RANGE	DIM D	DIM E	RADIUS F	
	18-20	.104/2.64	.104/2.64	.021/.53	.042/1.07-.103/2.62	.139/3.53	.120/3.05	.050/1.27	HT-0073
	22-26	.070/1.78	.070/1.78	.017/.43	.036/.91-.103/2.62	.139/3.53	.120/3.05	.050/1.27	HT-0095
	28-32	.054/1.37	.058/1.47	.011/.28	.028/.71-.054/1.37	.115/2.92	.105/2.67	.040/1.02	

NOTES:

1. TERMINAL MATES WITH  $.025 \pm .002 / 0.64 \pm 0.05$  SQUARE OR ROUND PIN.
- ② WHEN MEASURED ALONG DATUM -E- WITHIN  $.340 / 8.64$  REF DIM.
3. PRODUCT SPECIFICATION: BUS-12-067.  
APPLICATION SPECIFICATIONS:  
TA-75: TERMINAL DATA FOR USE WITH MINI LATCH HOUSING.  
TA-146: TERMINAL DATA FOR CONTACTS NOT USED IN HOUSINGS.  
TA-210: TERMINAL DATA FOR CONTACTS USED WITH MINI ROD HOUSINGS.  
TA-228: APPLICATIONS USING 20 AWG WIRE.  
TA-531: INSTALLING AND REMOVING TERMINALS.
- ④ PRODUCT MEETS EUROPEAN UNION DIRECTIVES AND OTHER COUNTRY REGULATIONS AS DESCRIBED IN GS-22-008.
5. THIS PRODUCT IS NOT INTENDED TO BE EXPOSED TO MANUFACTURING SOLDERING PROCESSES.
- ⑥ THIS PRODUCT HAS 100% TIN PLATING IN THE INTERFACE AND HAS NOT BEEN TESTED FOR WHISKER GROWTH IN ALL INTERCONNECT ENVIRONMENTS.
- ⑦ REMAINDER OF TOP OF PART TO BE GOLD FLASH OVER  $50\mu" / 1.27\mu\text{m}$  NICKEL. BACKSIDE OF TERMINALS TO BE PLATED WITH  $30\mu" / 0.76\mu\text{m}$  NICKEL ONLY.



FCconnect.com

Copyright FCJ

mat'l. code SEE TABLE				surface <input checked="" type="checkbox"/>	tolerance	projection	product family PV TERMINALS
ltr	ecrn no	dr	date	tolerances unless otherwise specified			title
AM				angles	linear	INCH/MM	MINI PV™ RECEPTACLE CRIMP TO WIRE
						scale 1:1	
				dr	T. BREWBAKER	2006-04-18	sheet 2 of 6
				engr	T. BREWBAKER	2006-04-18	size
				chr	T. BREWBAKER	2006-04-18	A3
				appd	T. BREWBAKER	2006-04-18	type
sheet	revision						Product Customer Drawing
index	sheet						

MATERIAL & PLATING		SPRING THICKNESS DIM H±.0005/0.012	AWG RANGE	REELED NOTE 4	LOOSE NOTE 4	PLATING AVAILABILITY							
1/4 HARD BRASS BODY	Be/Cu SPRING					-000	-000LF	-001	-001LF	-002	-002LF		
CONTACT AREA UNDERPLATING: 50μ"/1.27μ Ni CONTACT AREA: 15μ"/0.38μ Au INSIDE BOX AREA: -000LF Au FLASH -001LF 15μ"/0.38μ Au -002LF 6μ"/0.15μ Au REMAINDER: -000LF SEE NOTE 7 -001LF 15μ"/0.38μ Au -002LF Au FLASH	Au FLASH	.0035/0.089	18-20	48241	48250	NO	YES	NO	NO	NO	NO		
			22-26	48242	48251	NO	YES	NO	NO	NO	NO		
			28-32	48243	48252	NO	YES	NO	NO	NO	NO		
		.0048/0.122	18-20	48244	48253	NO	YES	NO	NO	NO	NO		
			22-26	48245	48254	NO	YES	NO	NO	NO	NO		
			28-32	48246	48255	NO	YES	NO	NO	NO	NO		
		.0058/0.147	18-20	94011	94014	NO	NO	NO	NO	NO	NO	OBS.	
			22-26	94012	94015	NO	NO	NO	NO	NO	NO	OBS.	
			28-32	94013	94016	NO	NO	NO	NO	NO	NO	OBS.	
		.0065/0.165	18-20	48247	48256	NO	YES	NO	NO	NO	NO		
			22-26	48248	48257	NO	YES	NO	NO	NO	NO		
			28-32	48249	48258	NO	YES	NO	NO	NO	NO		
CONTACT AREA UNDERPLATING: 50μ"/1.27μ Ni CONTACT AREA: 30μ"/0.76μ Au INSIDE BOX AREA: -000LF Au FLASH -001LF 30μ"/0.76μ Au -002LF 8μ"/0.2μ Au REMAINDER: -000LF SEE NOTE 7 -001LF 30μ"/0.76μ Au -002LF Au FLASH	Au FLASH	.0035/0.089	18-20	48231	48266	NO	YES	NO	NO	NO			
			22-26	48049	48235	NO	YES	NO	NO	NO	NO	YES	
			28-32	48048	48238	NO	YES	NO	NO	NO	NO	YES	
		.0048/0.122	18-20	48047	48232	NO	YES	NO	NO	NO	NO	YES	
			22-26	48046	48234	NO	YES	NO	NO	NO	NO	YES	
			28-32	48045	48237	NO	YES	NO	NO	NO	NO	YES	
		.0058/0.147	18-20	94017	94019	NO	NO	NO	NO	NO	NO	NO	OBS.
			22-26	94018	94020	NO	NO	NO	NO	NO	NO	NO	OBS.
			28-32	93259	94021	NO	NO	NO	NO	NO	NO	NO	OBS.
		.0065/0.165	18-20	48052	48233	NO	YES	NO	NO	NO	NO	YES*	
			22-26	48051	48236	NO	YES	NO	NO	NO	NO	YES	
			28-32	48050	48239	NO	YES	NO	NO	NO	NO	YES	

\* LOOSE PIECE NOT AVAILABLE

mat'l. code SEE TABLE				surface ✓		tolerance		projection ⊕		product family PV TERMINALS	
ltr	ecrn no	dr	date	tolerances unless otherwise specified				title		MINI PV™ RECEPTACLE CRIMP TO WIRE	
AM				angles	linear	.XX±.01/.X±.3 .XXX±.005/.XX±.13 XXXX±.0020/XXX±.051		INCH/MM		sheet 3 of 6 size	
								scale 1:1		A3	
				dr	T. BREWBAKER	2006-04-18				dwg no	
				engr	T. BREWBAKER	2006-04-18				47212	
				chr	T. BREWBAKER	2006-04-18					
				appd	T. BREWBAKER	2006-04-18					
sheet index	revision sheet									type Product Customer Drawing	

MATERIAL & PLATING		SPRING THICKNESS DIM H±.0005/0.012	AWG RANGE	REELED NOTE 4	LOOSE NOTE 4	PLATING AVAILABILITY						
1/4 HARD BRASS BODY	Be/Cu SPRING					-000	-000LF	-001	-001LF	-002	-002LF	
CONTACT AREA UNDERPLATING: 50µ"/1.27µ Ni CONTACT AREA: 40µ"/1.02µ Au INSIDE BOX AREA: -000LF Au FLASH -001LF 8µ"/0.2µ Au -002LF 8µ"/0.2µ Au REMAINDER: -000LF SEE NOTE 7 -001LF 8µ"/0.2µ Au -002LF Au FLASH	Au FLASH	.0035/0.089	18-20	48276	N/A	NO	NO	NO	NO	NO	YES	
			22-26	47457	47743	NO	YES	NO	YES	NO	YES	
			28-32	47456	47742	NO	YES	NO	YES	NO	YES	
		.0048/0.122	18-20	47441	47713	NO	YES	NO	YES	NO	YES	
			22-26	47439	47712	NO	YES	NO	YES	NO	YES	
			28-32	47437	47711	NO	YES	NO	YES	NO	YES	
		.0058/0.147	18-20	94022	94025	NO	NO	NO	NO	NO	NO	OBS.
			22-26	94023	94026	NO	NO	NO	NO	NO	NO	OBS.
			28-32	94024	94027	NO	NO	NO	NO	NO	NO	OBS.
		.0065/0.165	18-20	47566	47746	NO	YES	NO	YES	NO	YES	
			22-26	47565	47745	NO	YES	NO	YES	NO	YES	
			28-32	47564	47744	NO	YES	NO	YES	NO	YES	
DISCONTINUED				48191	48194							
DISCONTINUED				48192	48195							
DISCONTINUED				48193	48196							
CONTACT AREA UNDERPLATING: 50µ"/1.27µ Ni CONTACT AREA: 75µ"/1.91µ Au INSIDE BOX AREA: -000LF Au FLASH -001LF 75µ"/1.91µ Au -002LF 30µ"/0.76µ Au REMAINDER: -000LF SEE NOTE 7 -001LF 75µ"/1.91µ Au -002LF 15µ"/0.38µ Au	Au FLASH	.0035/0.089	18-20	47785	48014	NO	YES	NO	NO	NO	NO	
			22-26	47784	48015	NO	NO	NO	NO	NO	NO	OBS.
			28-32	47783	48013	NO	NO	NO	NO	NO	NO	OBS.
		.0048/0.122	18-20	47220	47707	NO	NO	NO	NO	NO	NO	OBS.
			22-26	47216	47706	NO	YES	NO	NO	NO	NO	
			28-32	47212	47705	NO	YES	NO	NO	NO	NO	
		.0058/0.147	18-20	94028	94031	NO	NO	NO	NO	NO	NO	OBS.
			22-26	94029	94032	NO	NO	NO	NO	NO	NO	OBS.
			28-32	94030	94033	NO	NO	NO	NO	NO	NO	OBS.



Copyright FCI

mat'l. code SEE TABLE				surface ✓	tolerance	projection ⊕	product family PV TERMINALS
ltr	ecn no	dr	date	tolerances unless otherwise specified			title
AM				angles	linear	INCH/MM	MINI PV™ RECEPTACLE CRIMP TO WIRE
					.XX±.01/.X±.3	scale 1:1	
					.XXX±.005/.XX±.13		
					.XXXX±.0020/.XXX±.051		
				dr	T. BREWBAKER	2006-04-18	dwg no
				engr	T. BREWBAKER	2006-04-18	sheet 4 of 6
				chr	T. BREWBAKER	2006-04-18	size
				appd	T. BREWBAKER	2006-04-18	A3
sheet	revision						type
index	sheet						Product Customer Drawing

MATERIAL & PLATING		SPRING THICKNESS DIM H±.0005/0.012	AWG RANGE	REELED NOTE 4	LOOSE NOTE 4	PLATING AVAILABILITY						OBS.
1/4 HARD BRASS BODY	Be/Cu SPRING					-000	-000LF	-001	-001LF	-002	-002LF	
PRE-PLATED: UNDERPLATING: 50μ"/1.27μ Ni OVERPLATING: 100-200μ"/2.54-5.08μ 60/40 TIN LEAD "LF NOT AVAILABLE" SEE LEAD-FREE EQUIVALENTS BELOW	Sn PLATED	.0035/0.089	22-26	47445	47747	NO	NO	NO	NO	NO	NO	OBS.
			28-32	47446	47748	NO	NO	NO	NO	NO	NO	OBS.
		.0048/0.122	18-20	47221	47716	NO	NO	NO	NO	NO	NO	OBS.
			22-26	47217	47715	NO	NO	NO	NO	NO	NO	OBS.
		.0058/0.147	28-32	47213	47714	NO	NO	NO	NO	NO	NO	OBS.
			18-20	94034	94037	NO	NO	NO	NO	NO	NO	OBS.
		.0065/0.165	22-26	94035	94038	NO	NO	NO	NO	NO	NO	OBS.
			28-32	94036	94039	NO	NO	NO	NO	NO	NO	OBS.
		.0065/0.165	18-20	47648	47749	NO	NO	NO	NO	NO	NO	OBS.
			22-26	47649	47750	NO	NO	NO	NO	NO	NO	OBS.
		.0065/0.165	28-32	47650	47751	NO	NO	NO	NO	NO	NO	OBS.
			.0035/0.089	22-26	47445	47747	NO	YES	NO	NO	NO	NO
28-32	47446	47748		NO	YES	NO	NO	NO	NO			
.0048/0.122	18-20	47221	47716	NO	YES	NO	NO	NO	NO			
	22-26	47217	47715	NO	YES	NO	NO	NO	NO			
.0058/0.147	28-32	47213	47714	NO	YES	NO	NO	NO	NO			
	18-20	94034	94037	NO	NO	NO	NO	NO	NO	OBS.		
.0065/0.165	22-26	94035	94038	NO	NO	NO	NO	NO	NO	OBS.		
	28-32	94036	94039	NO	NO	NO	NO	NO	NO	OBS.		
.0065/0.165	18-20	47648	47749	NO	YES	NO	NO	NO	NO			
	22-26	47649	47750	NO	YES	NO	NO	NO	NO			
.0065/0.165	28-32	47650	47751	NO	YES	NO	NO	NO	NO			



Copyright FCJ

mat'l. code SEE TABLE				surface <input checked="" type="checkbox"/>	tolerance	projection 	product family PV TERMINALS
ltr	ecr no	dr	date	tolerances unless otherwise specified		INCH/MM scale 1:1	title MINI PV™ RECEPTACLE CRIMP TO WIRE
AM				angles	.XX±.01/.X±.3		
				linear	.XXX±.005/.XX±.13 XXXX±.0020/.XXX±.051		
				dr	T. BREWBAKER	2006-04-18	dwg no 47212
				engr	T. BREWBAKER	2006-04-18	sheet 5 of 6
				chr	T. BREWBAKER	2006-04-18	size A3
				appd	T. BREWBAKER	2006-04-18	type Product Customer Drawing
sheet index	revision	sheet					

MATERIAL & PLATING		SPRING THICKNESS DIM H±.0005/0.012	AWG RANGE	REELED NOTE 4	LOOSE-PIECE NOTE 4			
1/4 HARD BRASS BODY	Be/Cu SPRING							
UNDERPLATING: 50u" X 1.27u" Ni CONTACT AREA: 30u" / 0.76u" GXT INSIDE BOX AREA: -600 Au FLASH REMAINDER: -600 Au FLASH	Au FLASH	.0035/0.089	18-20	48231-600	48266-600	OBS.		
			22-26	48049-600	48235-600	OBS.		
			28-32	48048-600	48238-600	OBS.		
		CONTINUED		.0048/0.122	18-20	48047-600	48232-600	OBS.
					22-26	48046-600	48234-600	OBS.
					28-32	48045-600	48237-600	OBS.
				.0058/0.147	18-20	94017-600	94019-600	OBS.
					22-26	94018-600	94020-600	OBS.
					28-32	93259-600	94021-600	OBS.
				.0065/0.165	18-20	48052-600	48233-600	OBS.
					22-26	48051-600	48236-600	OBS.
					28-32	48050-600	48239-600	OBS.



FCconnect.com

Copyright FCJ

mat'l. code SEE TABLE				surface ✓	tolerance	projection ⊕	product family PV TERMINALS
ltr	ecn no	dr	date	tolerances unless otherwise specified		INCH/MM	title
AM				angles	.XX±.01/.X±.3		MINI PV™ RECEPTACLE CRIMP TO WIRE
				linear	.XXX±.005/.XX±.13	scale 1:1	
					XXXX±.0020/.XXX±.051		
				dr	T. BREWBAKER 2006-04-18	FCJ	dwg no
				engr	T. BREWBAKER 2006-04-18		sheet 6 of 6
				chr	T. BREWBAKER 2006-04-18		size
				appd	T. BREWBAKER 2006-04-18		A3
sheet index	revision sheet						type Product Customer Drawing