

PRODUCT NO.  
10119313-301TLF

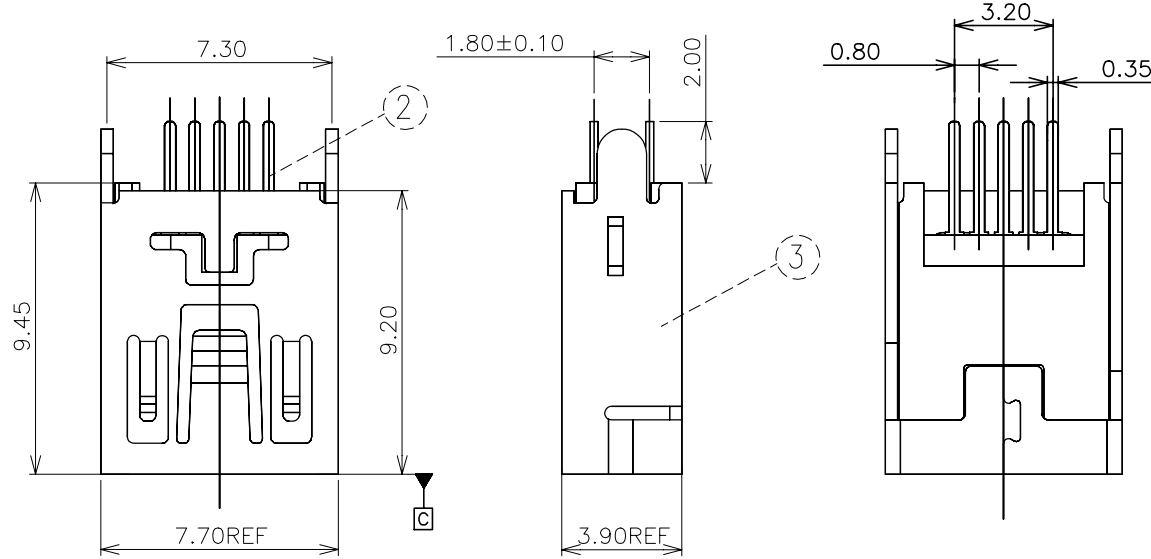

NOTES:

- 1.MATERIAL:  
HOUSING: THERMOPLASTIC, UL 94V-0 RATED. COLOR IN BLACK.  
CONTACT: COPPER ALLOY  
SHELL: COPPER ALLOY.
- 2.FINISH:  
CONTACT:UNDERPLATED 50u"MIN. NICKEL, OVER ALL;  
100u" MIN. PURE MATTE TIN PLATED IN SOLDERING AREA;  
30u" MIN. GOLD PLATING ON CONTACT AREA.  
SHIELD: NICKEL 80u" MIN. PLATED OVER ALL.
3. THE HOUSING WILL WITHSTAND EXPOSURE TO 260 DEGREE C PEAK TEMPERATURE FOR 10 SECONDS IN A IR REFLOW APPLICATION. AND THIS PRODCUT MEETS EUROPEAN UNION DIRECTIVES AND OTHER COUNTRY REGULATIONS AS DESCRIBED IN GS-22-008.
4. PRODUCT SPECIFICATION: GS-12-174; PACKAGING SPECIFICATION: GS-14-873.
5. PRODUCT ORDERING DATA :  
FOR LEAD-FREE

10119313 - X X X X LF

- LF: LEAD FREE PLATING
- PACKAGING METHOD:  
T: TRAY PACKAGING STYLE.
- SHELL PEG OPTION:  
1 : DIP TYPE, SEE PAGE 1  
2 : SMT TYPE, SEE PAGE 2
- HSG MATERIAL:  
0: LCP
- PLATING IN CONTACT AREA:  
3 : 30u" MIN. Au .

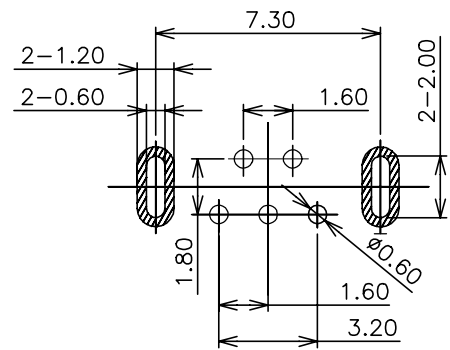
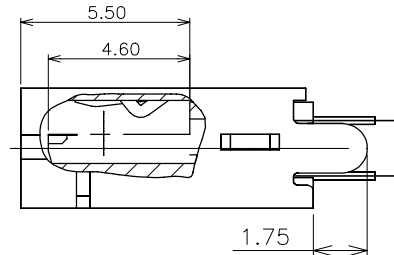
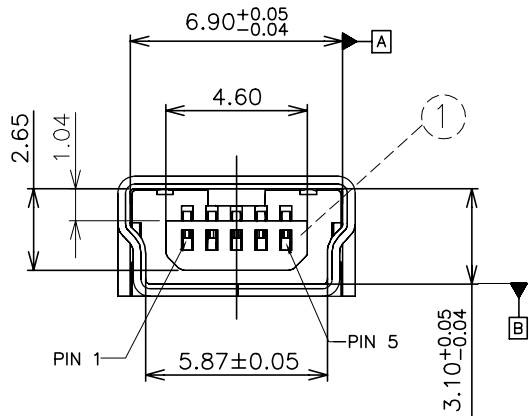

RECOMMENDED PCB LAYOUT

ITEM	NAMES	QT'Y	MATERIAL	FINISH
3	SHIELD	1	COPPER ALLOY	SEE NOTE 2
2	TERMINAL	5	COPPER ALLOY	SEE NOTE 2
1	HOUSING	1	THERMOPLASTIC	COLOR:BLACK

mat'l. code				tolerances unless otherwise specified			CUSTOMER COPY		FCI www.fciconnect.com		
ltr	ecn no	dr	date	linear	.0 ± 0.30	projection	title MINI USB 5PF VERTICAL TYPE MINI USB B RECEPTACLE				
A	-	A.ZH	05/03/12	angles	.00 ± 0.20		product family: Mini USB		code		
					.000 ± 0.10		MM	size	dwg no	NT	
				dr	ANDY ZHANG	05/03/2012	scale	10119313		sheet	
				enr	ANDY ZHANG	05/03/2012	1 : 1			1 of 2	
				chr	RICK BIAN	05/03/2012					
				appd	RICK BIAN	05/03/2012					
sheet index	revision sheet	A	1~2								

PRODUCT NO.  
10119313-302TLF

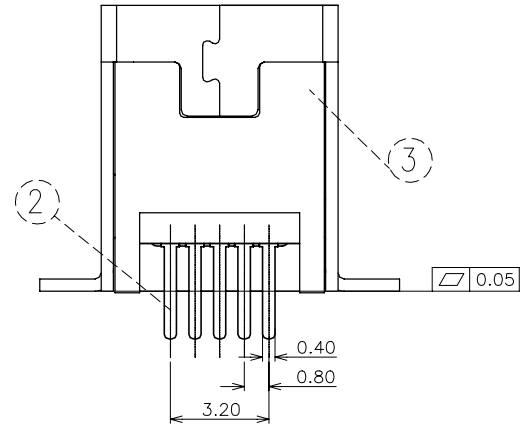
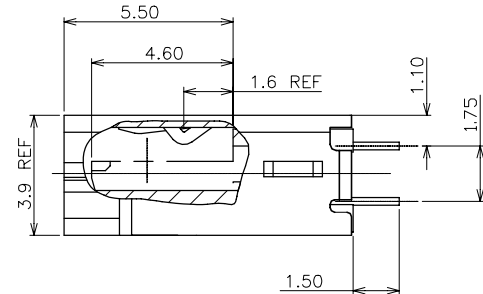
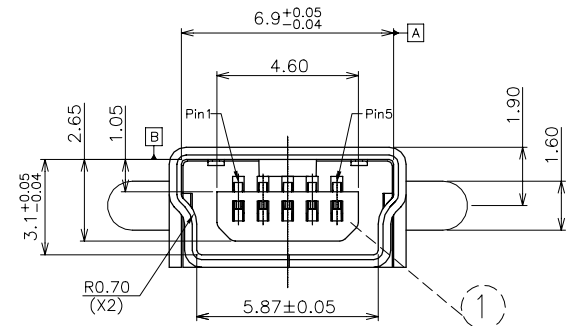
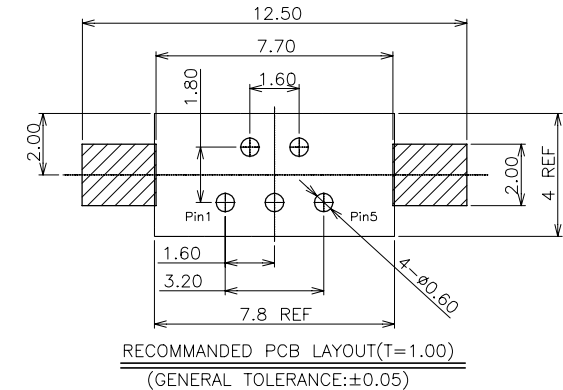
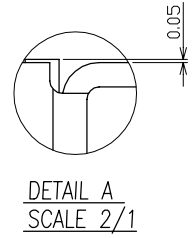
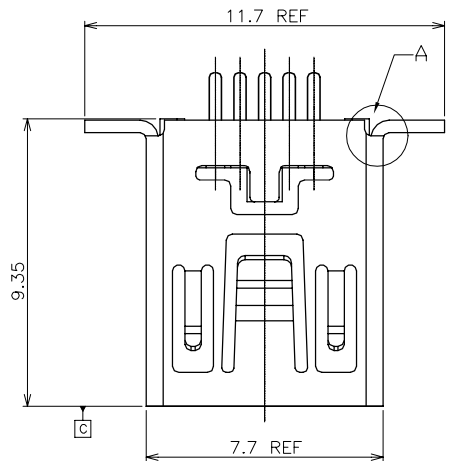

PLEASE SEE PAGE ONE FOR THE NOTES

mat'l. code		tolerances unless otherwise specified		CUSTOMER COPY		 www.fciconnect.com	
ltr	ecn no	dr	date	linear	.0 ± 0.30	projection	title MINI USB 5PF VERTICAL TYPE MINI USB B RECEPTACLE
A					.00 ± 0.20		
				angles	.000 ± 0.10	 MM	product family: Mini USB code NT
				dr	± 2°		
				enr	ANDY ZHANG 05/03/2012	scale	size dwg no 10119313
				chr	RICK BIAN 05/03/2012		
				appd	RICK BIAN 05/03/2012		
sheet index	revision sheet					1 : 1	sheet 2 of 2