

LC709203F



ON Semiconductor®

<http://onsemi.com>

CMOS LSI

Battery Monitor IC for 1-Cell Lithium-ion (Li+)

Overview

The LC709203F is an IC that measures the remaining power level of 1-cell lithium-ion (Li+) batteries used for portable equipment etc.

This product reduces fuel gauge errors with a unique correction technology during measurement of battery temperature and voltage.

This technology has inherent high precision without the need for an external sense resistor.

Applications

- Wireless Handsets
- Smartphones / PDA devices
- MP3 players
- Digital cameras
- Portable Game Players
- USB-related devices

Features

- High accuracy of remaining battery power measurements
- Precision Voltage Measurement
- No external sense resistor
- Alert function
- Interface
 - I²C Interface (up to 400 kHz supported)
- Low power consumption
- Corresponding battery models for various battery electrode materials
- Ports

• I ² C communication pin	: 2 (SDA, SCL)
• Battery temperature reading control pin	: 1 (TSW)
• Analog voltage input pin for battery temperature	: 1 (TSENSE)
• External alarm / Interrupt for Low-Battery warning	: 1 (ALARMB)
• Power supply pin	: 2 (VSS, VDD)
- Package form
 - VDFN8 3×4, 0.65P : Lead-free type
 - WLCSP9, 1.60×1.76 : Lead-free type

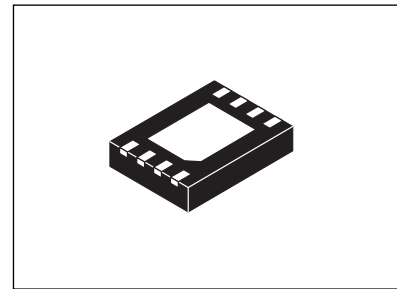

VDFN8 3x4, 0.65P

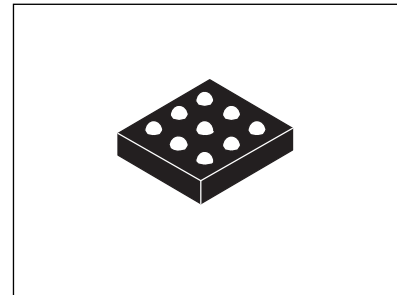

WLCSP9, 1.60x1.76

* I²C Bus is a trademark of Philips Corporation.

ORDERING INFORMATION

See detailed ordering and shipping information on page 12 of this data sheet.

Package Dimensions

unit : mm

VDFN8 3x4, 0.65P
CASE 509AF
ISSUE B

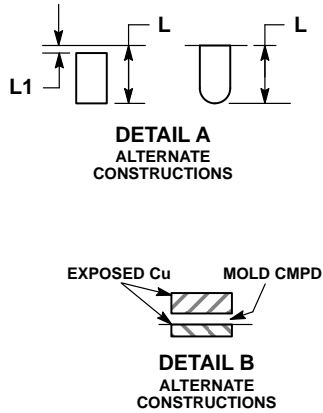
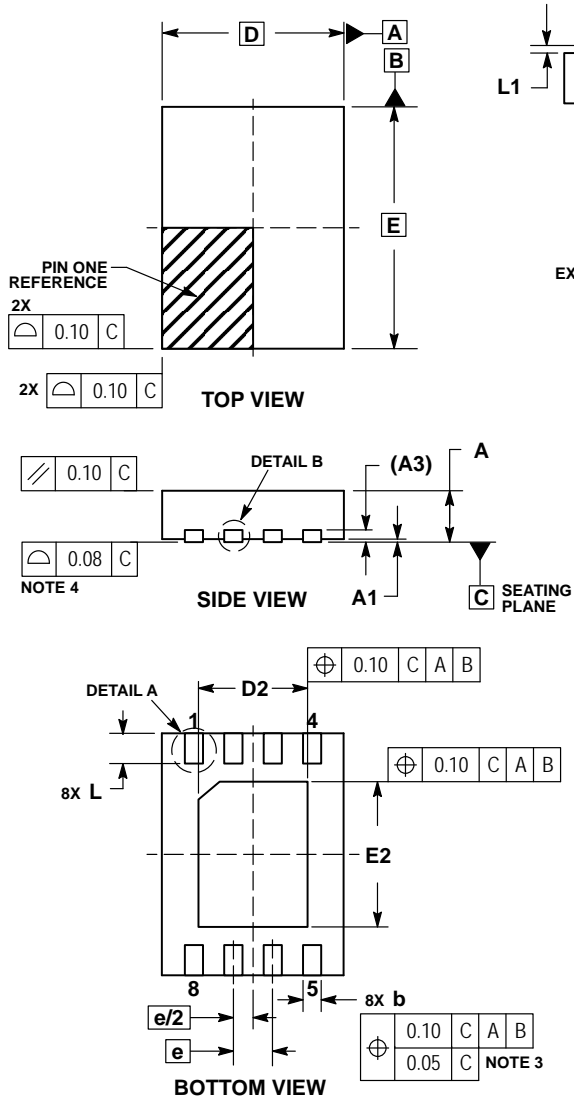

- NOTES:
1. DIMENSIONING AND TOLERANCING PER ASME Y14.5M, 1994.
 2. CONTROLLING DIMENSION: MILLIMETERS.
 3. DIMENSION b APPLIES TO PLATED TERMINAL AND IS MEASURED BETWEEN 0.15 AND 0.30mm FROM THE TERMINAL TIP.
 4. PROFILE TOLERANCE APPLIES TO THE EXPOSED PAD AS WELL AS THE LEADS.

MILLIMETERS		
DIM	MIN	MAX
A	---	0.80
A1	0.00	0.05
A3	0.20	REF
b	0.20	0.30
D	3.00 BSC	
D2	1.70	1.90
E	4.00 BSC	
E2	2.30	2.50
e	0.65 BSC	
L	0.45	0.55
L1	---	0.10

GENERIC MARKING DIAGRAM*

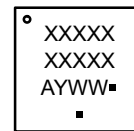

- A = Assembly Location
- Y = Year
- WW = Work Week
- = Pb-Free Package

(Note: Microdot may be in either location)

*This information is generic. Please refer to device data sheet for actual part marking. Pb-Free indicator, "G" or microdot "■", may or may not be present.

RECOMMENDED SOLDERING FOOTPRINT*

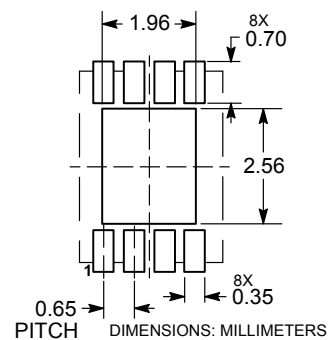

*For additional information on our Pb-Free strategy and soldering details, please download the ON Semiconductor Soldering and Mounting Techniques Reference Manual, SOLDERRM/D.

WLCSP9, 1.60x1.76
CASE 567JH
ISSUE B

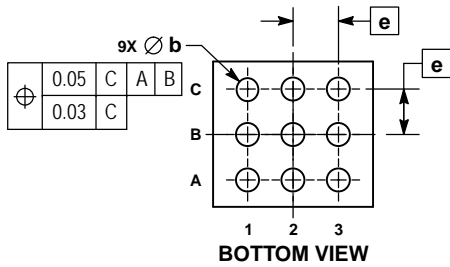
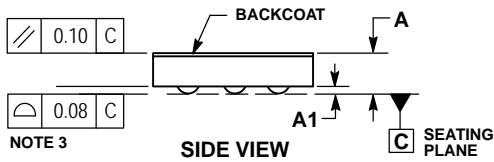
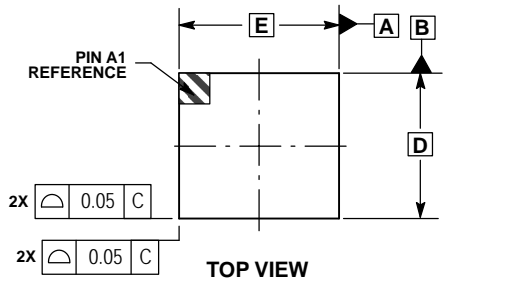

- NOTES:
1. DIMENSIONING AND TOLERANCING PER ASME Y14.5M, 1994.
 2. CONTROLLING DIMENSION: MILLIMETERS.
 3. COPLANARITY APPLIES TO THE SPHERICAL CROWNS OF THE SOLDER BALLS.

MILLIMETERS		
DIM	MIN	MAX
A	---	0.51
A1	0.09	0.19
b	0.20	0.30
D	1.60 BSC	
E	1.76 BSC	
e	0.50 BSC	

RECOMMENDED SOLDERING FOOTPRINT*

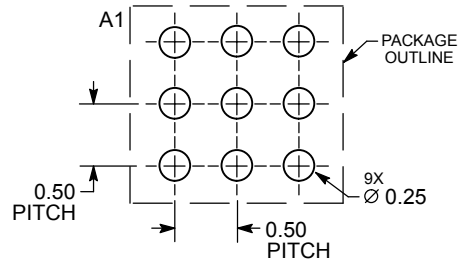

DIMENSIONS: MILLIMETERS

*For additional information on our Pb-Free strategy and soldering details, please download the ON Semiconductor Soldering and Mounting Techniques Reference Manual, SOLDERRM/D.

LC709203F

Pin Assignment

VDFN8 3x4, 0.65P “Lead-free Type”

WLCSP9, 1.60x1.76 “Lead-free Type”

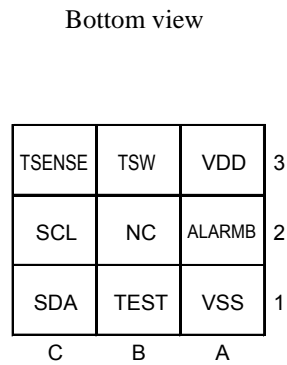
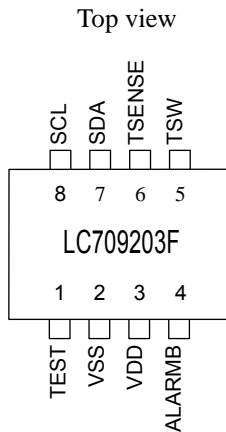

Pin Function

VDFN8	WLP9	Pin Name	I/O	Description
1	1B	TEST	I	Factory Test pin *Connect to V _{SS} .
2	1A	V _{SS}	-	Connect to the - terminal of the battery.
3	3A	V _{DD}	-	Connect to the + terminal of the battery.
4	2A	ALARMB	O	Alert indication. An active low output used to indicate specified condition thresholds have been met. *When you do not use an alert function, please connect with V _{SS} . (Note 3)
5	3B	TSW	O	Battery temperature reading control pin (Note.1)
6	3C	TSENSE	I	Battery temperature analog voltage input pin (Note.2)
7	1C	SDA	I/O	I ² C data pin
8	2C	SCL	I/O	I ² C clock pin
-	2B	NC	-	Not used pin. *Recommend to connect to V _{SS} .
-	-	EP	-	Exposed Pad, must not be connected.

(Note 1)

This pin provides power for the thermistor and goes high during a temperature read operation from Command code x08.

(Note 2)

If TSENSE is not used leave leads TSW and TSENSE disconnected, as in figure 4 and set bit 0 of command code register x16 low.

If TSENSE is utilized connect as in figure 5 with resistor network and set bit 0 of command code register x16 high.

(Note 3)

ALARMB indicates a low RSOC, or an under voltage battery.

Alert Function

- Configurable Alert Indicator
- Low RSOC
- Battery Under Voltage

Alarm RSOC Function

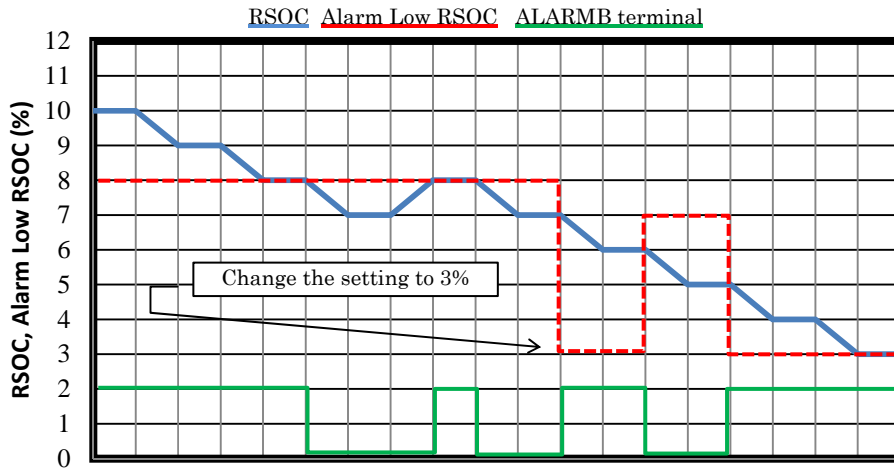

Block Diagram

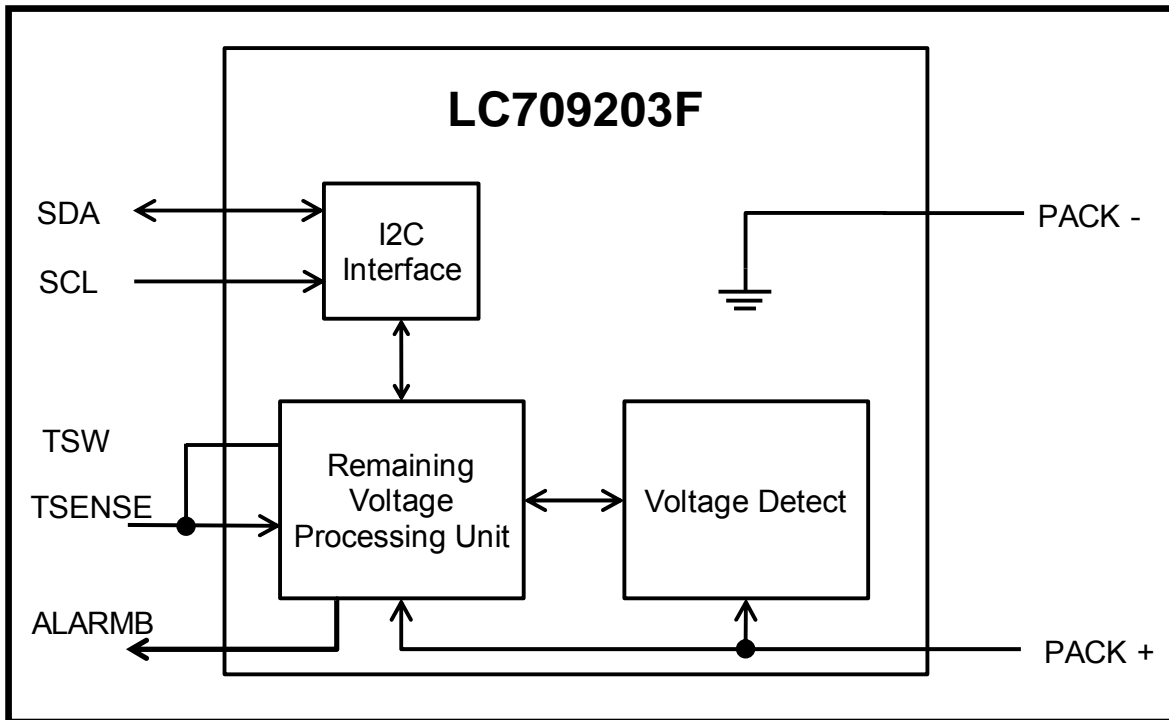

LC709203F

Absolute Maximum Ratings at $T_a = 25^\circ\text{C}$, $V_{SS} = 0\text{V}$

Parameter	Symbol	Pin/Remarks	Conditions	Specification			Unit	
				V_{DD} [V]	min	typ		max
Maximum supply voltage	$V_{DD\ max}$	V_{DD}			-0.3		+6.5	V
Input voltage	V_I (1)	TSENSE			-0.3		$V_{DD} + 0.3$	
Output voltage	V_O (1)	TSW			-0.3		$V_{DD} + 0.3$	
	V_O (2)	ALARMB			-0.3			
Input/output voltage	V_{IO} (1)	SDA, SCL			-0.3		+5.5	
Allowable power dissipation	$P_d\ max$	VDFN8	$T_a = -40\ to\ +85^\circ\text{C}$				480	mW
		WLP9					210	
Operating ambient temperature	T_{opr}				-40		+85	$^\circ\text{C}$
Storage ambient temperature	T_{stg}				-55		+125	

Stresses exceeding those listed in the Maximum Ratings table may damage the device. If any of these limits are exceeded, device functionality should not be assumed, damage may occur and reliability may be affected.

Allowable Operating Conditions at $T_a = -40\ to\ +85^\circ\text{C}$, $V_{SS} = 0\text{V}$

Parameter	Symbol	Pin/Remarks	Conditions	Specification			unit	
				V_{DD} [V]	min	typ		max
Operating supply voltage	V_{DD} (1)	V_{DD}			2.5		4.5	V
High level input voltage	V_{IH} (1)	TSENSE		2.5 to 4.5	$0.7V_{DD}$		V_{DD}	
	V_{IH} (2)	ALARMB, SDA, SCL		2.5 to 4.5	1.4			
Low level input voltage	V_{IL} (1)	TSENSE		2.5 to 4.5	V_{SS}		$0.25V_{DD}$	
	V_{IL} (2)	ALARMB, SDA, SCL		2.5 to 4.5			0.5	

Functional operation above the stresses listed in the Recommended Operating Ranges is not implied. Extended exposure to stresses beyond the Recommended Operating Ranges limits may affect device reliability.

LC709203F

Electrical Characteristics at Ta = -40 to +85°C, VSS = 0V

Parameter	Symbol	Pin/Remarks	Conditions	Specification			Unit	
				VDD[V]	min	typ		max
High level input current	I _{IH} (1)	SDA, SCL	V _{IN} = V _{DD} (including output transistor off leakage current)	2.5 to 4.5			1	μA
Low level input current	I _{IL} (1)	SDA, SCL	V _{IN} = V _{SS} (including output transistor off leakage current)	2.5 to 4.5	-1			
High level output voltage	V _{OH} (1)	TSW	I _{OH} = -0.4 mA	3.0 to 4.5	V _{DD} -0.4			V
	V _{OH} (2)		I _{OH} = -0.2 mA	2.5 to 4.5	V _{DD} -0.4			
Low level output voltage	V _{OL} (1)	TSW, ALARMB, SDA, SCL	I _{OL} = 3.0 mA	3.0 to 4.5			0.4	
	V _{OL} (2)		I _{OL} = 1.3 mA	2.5 to 4.5			0.4	
Hysteresis voltage	V _{HYS} (1)	SDA, SCL		2.5 to 4.5		0.1V _{DD}		
Pin capacitance	CP	All pins	Pins other than the pin under test V _{IN} = V _{SS} Ta = 25°C	2.5 to 4.5		10		pF
Consumption current (Note 1)	I _{DD} (1)	V _{DD}	Normal Mode	2.5 to 4.5		15	26	μA
	I _{DD} (2)		Accurate ECO Mode	2.5 to 4.5		2	4.5	
	I _{DD} (3)		Sleep Mode	2.5 to 4.5		0.2	4	
Voltage measurement accuracy	V _{ME} (1)	V _{DD}	Ta = +25°C	3.6	-7.5		+7.5	mV/cell
	V _{ME} (2)		Ta = -20°C to +70°C	2.5 to 4.5	-20		+20	

Note 1 : Consumption current is a value in the range of -20°C to +70°C

Product parametric performance is indicated in the Electrical Characteristics for the listed test conditions, unless otherwise noted. Product performance may not be indicated by the Electrical Characteristics if operated under different conditions.

LC709203F

I²C Slave Characteristics at Ta = -40 to +85°C, V_{SS} = 0V

Parameter	Symbol	Pin/Remarks	Conditions	V _{DD} [V]	Specification		unit
					min	Max	
Clock frequency	TSCL	SCL		2.5 to 4.5		400	kHz
Bus free time between STOP condition and START condition	TBUF	SCL, SDA	See Fig. 1.		1.3		μs
Hold time (repeated) START condition First clock pulse is generated after this interval	THD:STA	SCL, SDA	See Fig. 1.		0.6		μs
Repeated START condition setup time	TSU:STA	SCL, SDA	See Fig. 1.		0.6		μs
STOP condition setup time	TSU:STO	SCL, SDA	See Fig. 1.		0.6		μs
Data hold time	THD:DAT	SCL, SDA	See Fig. 1.		0	0.9	μs
Data setup time	TSU:DAT	SCL, SDA	See Fig. 1.		100		ns
Clock low period	TLOW	SCL			1.3		μs
Clock high period	THIGH	SCL			0.6		μs
Clock/data fall time	TF	SCL, SDA			20 + 0.1C _B	300	ns
Clock/data rise time	TR	SCL, SDA			20 + 0.1C _B	300	ns

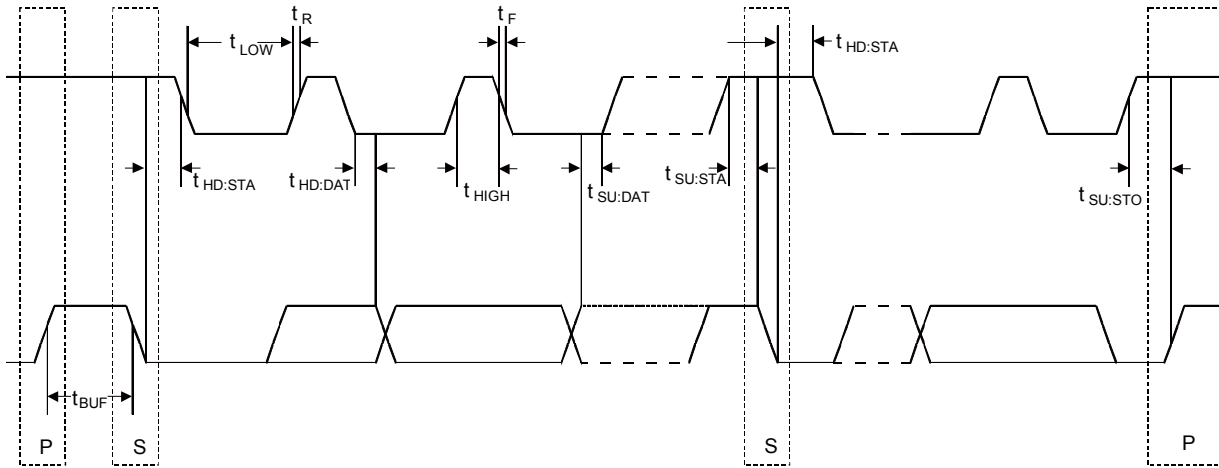

Figure 1 I²C Timing

Discharge Characteristics

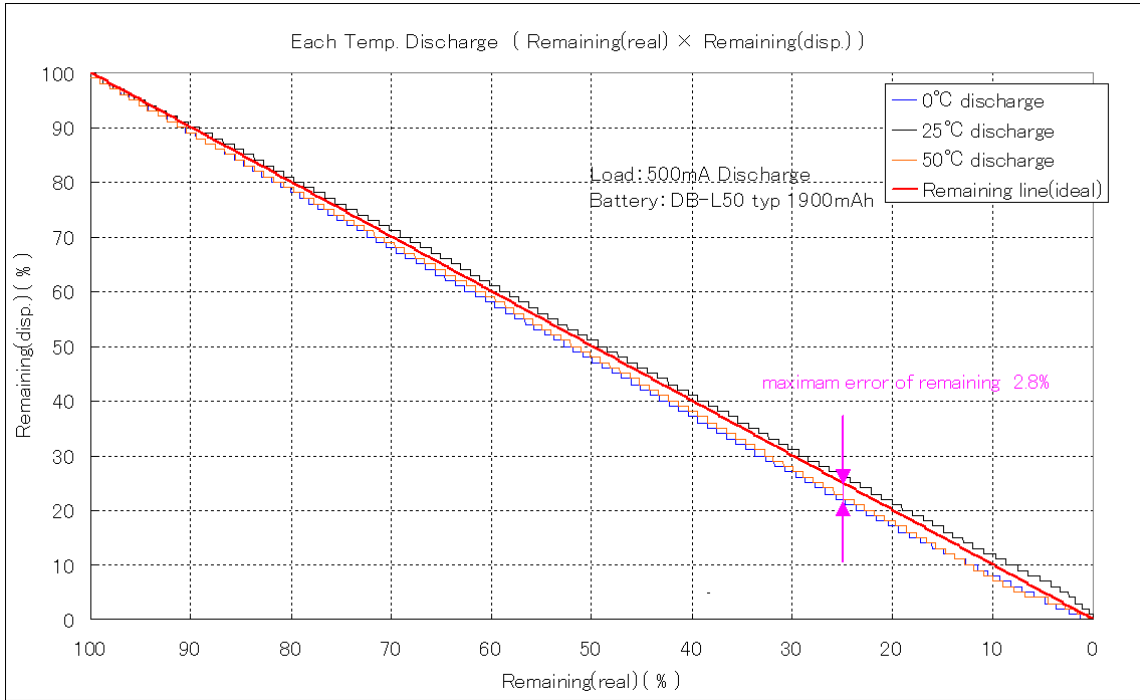

Figure 2 Discharge Characteristics by Temperature Change

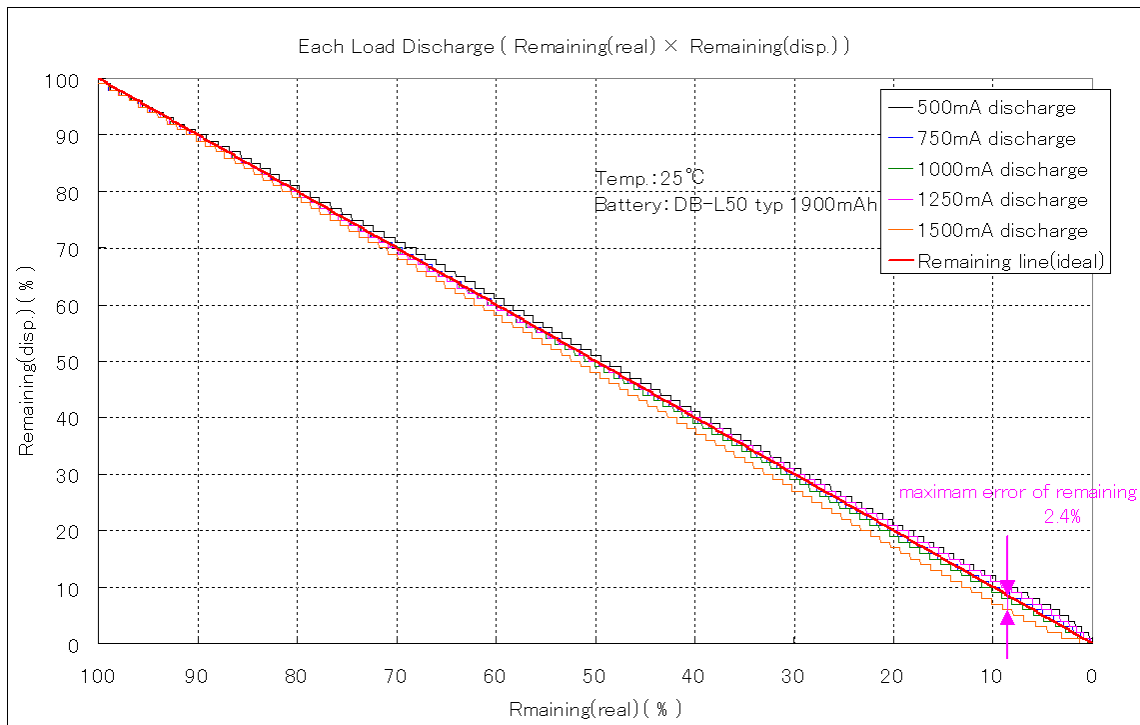

Figure 3 Discharge Characteristics by Load Change

LC709203F

Communication Protocol

Communication protocol type : I2C

Frequency : to 400kHz

IC address : 0x16 (It becomes "0001011X" when you write a binary, because the slave address is 7 bits. [X]=Rd/Wr.)

Bus Protocols

- S : Start Condition
- Sr : Repeated Start Condition
- Rd : Read (bit value of 1)
- Wr : Write (bit value of 0)
- A : ACK (bit value of 0)
- N : NACK (bit value of 1)
- P : Stop Condition
- CRC-8 : Slave Address to Last Data (CRC-8-ATM : ex.3778mV : 0x16,0x09,0x17,0xC2,0x0E → 0x86)
- : Master-to-Slave
- : Slave-to-Master
- ... : Continuation of protocol

Read Word Protocol

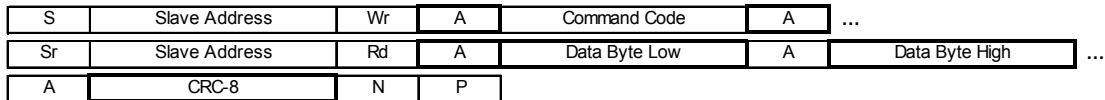

*When you do not read CRC-8, there is not the reliability of data. CRC-8-ATM ex : (5 bytes) 0x16,0x09,0x17,0xC2,0x0E → 0x86

Write Word Protocol

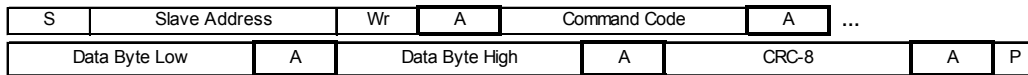

*When you do not add CRC-8, the Written data (Data byte Low /High) become invalid.

CRC-8-ATM ex : (4 bytes) 0x16, 0x09, 0x55, 0xAA → 0x3B

Command Code	Slave Functions	Stats	Range	Unit	Initial Value
0x06	Thermistor B	R/W	0x0000 to 0xFFFF	B	0x0D34
0x07	Initial RSOC	W	0xAA55	Value	-
0x08	Cell Temperature	R	0x0000 to 0xFFFF (Thermistor Mode)	0.1°K (0.0°C = 0x0AAC)	0x0BA6 (25°C)
		W	0x09E4 to 0x0D04 (Via I2C)		
0x09	Cell Voltage	R	0x0000 to 0xFFFF	mV	-
0x0A	Current Direction	R/W	0x0000 or 0x0001 or 0xFFFF	0x0001 : Charge Mode 0x0000 : Auto Mode 0xFFFF : Discharge Mode	0x0000
0x0B	Adjustment Pack Appli	R/W	0x0000 to 0xFFFF	Value	-
0x0C	Adjustment Pack Thermistor	R/W	0x0000 to 0xFFFF	Value	0x001E
0x0D	RSOC	R	0x0000 to 0x0064	%	-
	Set RSOC	W			
0x0F	Indicator To Empty	R	0x0000 to 0x03E8	Value	-
0x11	IC Version	R	0x0000 to 0xFFFF	Version	-
0x12	Change Of The Parameter	R/W	0x0000 or 0x0001	Please refer to a low er list	0x0000
0x13	Alarm Low RSOC	R/W	0x0000 to 0x0064	% (activate under)	0x0008
0x14	Alarm Low Cell Voltage	R/W	0x0000 to 0xFFFF	mV (activate under)	0x0000
0x15	IC Power Mode	R/W	0x0000 to 0x0002	0x0000 : Normal Mode 0x0001 : Accurate ECO 0x0002 : Sleep Mode	-
0x16	Status Bit	R/W	bit 0 : Thermistor Mode bit 1 to 15 : Reserved (fix 0)	0 : disable 1 : enable	0x0000
0x1A	Number Of The Parameter	R	0x0301 or 0x0504	Please refer to a low er list	-

	Type Of The Battery	Number Of The Parameter	Change Of The Parameter
LC709203F-01	Normal Voltage3.8V, Charge Voltage 4.35V	0x0301	0x0000
	Normal Voltage3.7V, Charge Voltage 4.2V		0x0001
LC709203F-04	ICR18650-26H (SAMSUNG)	0x0504	0x0000
	UR18650ZY (Panasonic)		0x0001

RSOC = Relative State Of Charge

0xXXXX = Hexadecimal notation

(Note)

Initialization from Host :

- The IC will initialize reading the battery temperature until Initialization sequence with serial port is executed. (Please see EVB manual for sequences.)

Control from Host :

- The Remaining State of Charge (RSOC) is normally read periodically.
- To read temperature the part will need a sequence of instructions and then returned to RSOC reading.

LC709203F

ORDERING INFORMATION

Device	Package	Shipping (Qty / Packing)
LC709203FQH-01TWG	VDFN8 3x4, 0.65P (Pb-Free / Halogen Free)	2000 / Tape & Reel
LC709203FQH-02TWG	VDFN8 3x4, 0.65P (Pb-Free / Halogen Free)	2000 / Tape & Reel
LC709203FQH-03TWG	VDFN8 3x4, 0.65P (Pb-Free / Halogen Free)	2000 / Tape & Reel
LC709203FQH-04TWG	VDFN8 3x4, 0.65P (Pb-Free / Halogen Free)	2000 / Tape & Reel
LC709203FXE-01MH	WLCSP9, 1.60x1.76 (Pb-Free / Halogen Free)	5000 / Tape & Reel
LC709203FXE-02MH	WLCSP9, 1.60x1.76 (Pb-Free / Halogen Free)	5000 / Tape & Reel
LC709203FXE-03MH	WLCSP9, 1.60x1.76 (Pb-Free / Halogen Free)	5000 / Tape & Reel
LC709203FXE-04MH	WLCSP9, 1.60x1.76 (Pb-Free / Halogen Free)	5000 / Tape & Reel

(Note)

The type of battery affects the performance to some degree. Contact your sales team for assistance in choosing the correct model.

ON Semiconductor and the ON logo are registered trademarks of Semiconductor Components Industries, LLC (SCILLC). SCILLC owns the rights to a number of patents, trademarks, copyrights, trade secrets, and other intellectual property. A listing of SCILLC's product/patent coverage may be accessed at www.onsemi.com/site/pdf/Patent-Marking.pdf. SCILLC reserves the right to make changes without further notice to any products herein. SCILLC makes no warranty, representation or guarantee regarding the suitability of its products for any particular purpose, nor does SCILLC assume any liability arising out of the application or use of any product or circuit, and specifically disclaims any and all liability, including without limitation special, consequential or incidental damages. "Typical" parameters which may be provided in SCILLC data sheets and/or specifications can and do vary in different applications and actual performance may vary over time. All operating parameters, including "Typicals" must be validated for each customer application by customer's technical experts. SCILLC does not convey any license under its patent rights nor the rights of others. SCILLC products are not designed, intended, or authorized for use as components in systems intended for surgical implant into the body, or other applications intended to support or sustain life, or for any other application in which the failure of the SCILLC product could create a situation where personal injury or death may occur. Should Buyer purchase or use SCILLC products for any such unintended or unauthorized application, Buyer shall indemnify and hold SCILLC and its officers, employees, subsidiaries, affiliates, and distributors harmless against all claims, costs, damages, and expenses, and reasonable attorney fees arising out of, directly or indirectly, any claim of personal injury or death associated with such unintended or unauthorized use, even if such claim alleges that SCILLC was negligent regarding the design or manufacture of the part. SCILLC is an Equal Opportunity/Affirmative Action Employer. This literature is subject to all applicable copyright laws and is not for resale in any manner.