

16 Mbit, serial Flash memory, 75 MHz SPI bus interface

Features

- 16 Mbit of Flash memory
- Page Program (up to 256 bytes) in 0.64 ms (typical)
- Sector Erase (512 Kbit) in 0.6 s (typical)
- Bulk Erase (16 Mbit) in 13 s (typical)
- 2.7 V to 3.6 V single supply voltage
- SPI bus compatible serial interface
- 75 MHz Clock rate (maximum)
- Deep Power-down mode 1 μ A (typical)
- Electronic signatures
 - JEDEC standard two-byte signature (2015h)
 - Unique ID code (UID) with 16 bytes read-only, available upon customer request
 - RES instruction, one-byte, signature (14h), for backward compatibility
- More than 100,000 Erase/Program cycles per sector
- Hardware Write Protection: protected area size defined by three non-volatile bits (BP0, BP1 and BP2)
- More than 20 year data retention
- Packages
 - ECOPACK® (RoHS compliant)



VFQFPN8 (MP)
6 x 5 mm (MLP8)



VDFPN8 (ME)
8 x 6 mm (MLP8)



SO8N (MN)
150 mils width



SO8W (MW)
208 mils width

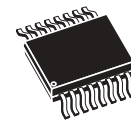

SO16 (MF)
300 mils width

Contents

1	Description	6
2	Signal description	8
2.1	Serial Data output (Q)	8
2.2	Serial Data input (D)	8
2.3	Serial Clock (C)	8
2.4	Chip Select (\overline{S})	8
2.5	Hold (\overline{HOLD})	8
2.6	Write Protect (\overline{W})	8
2.7	V _{CC} supply voltage	9
2.8	V _{SS} ground	9
3	SPI modes	10
4	Operating features	12
4.1	Page programming	12
4.2	Sector Erase and Bulk Erase	12
4.3	Polling during a Write, Program or Erase cycle	12
4.4	Active Power, Standby Power and Deep Power-down modes	12
4.5	Status Register	13
4.6	Protection modes	13
4.7	Hold condition	14
5	Memory organization	16
6	Instructions	18
6.1	Write Enable (WREN)	19
6.2	Write Disable (WRDI)	20
6.3	Read Identification (RDID)	21
6.4	Read Status Register (RDSR)	22
6.4.1	WIP bit	22
6.4.2	WEL bit	22
6.4.3	BP2, BP1, BP0 bits	22

6.4.4	SRWD bit	23
6.5	Write Status Register (WRSR)	24
6.6	Read Data Bytes (READ)	26
6.7	Read Data Bytes at Higher Speed (FAST_READ)	27
6.8	Page Program (PP)	28
6.9	Sector Erase (SE)	30
6.10	Bulk Erase (BE)	31
6.11	Deep Power-down (DP)	32
6.12	Release from Deep Power-down and Read Electronic Signature (RES)	33
7	Power-up and power-down	35
8	Initial delivery state	36
9	Maximum rating	37
10	DC and AC parameters	38
11	Package mechanical	46
12	Part numbering	52
13	Revision history	53

List of tables

Table 1.	Signal names	6
Table 2.	Protected area sizes	14
Table 3.	Memory organization	17
Table 4.	Instruction set	19
Table 5.	Read Identification (RDID) data-out sequence	21
Table 6.	Status Register format	22
Table 7.	Protection modes	25
Table 8.	Power-up timing and V_{WI} threshold	36
Table 9.	Absolute maximum ratings	37
Table 10.	Operating conditions	38
Table 11.	Data retention and endurance	38
Table 12.	AC measurement conditions	38
Table 13.	Capacitance	38
Table 14.	DC characteristics	39
Table 15.	AC characteristics (grade 6, T9HX technology)	40
Table 16.	AC characteristics (25 MHz operation, grade 3)	42
Table 17.	VFQFPN8 (MLP8) 8-lead very thin fine pitch quad flat package no lead, 6 × 5 mm, package mechanical data	47
Table 18.	VDFPN8 (MLP8) 8-lead very thin dual flat package no lead, 8 × 6 mm, package mechanical data	48
Table 19.	SO8N – 8 lead plastic small outline, 150 mils body width, package mechanical data	49
Table 20.	SO8 wide – 8 lead plastic small outline, 208 mils body width, package mechanical data	50
Table 21.	SO16 wide – 16-lead plastic small outline, 300 mils body width, mechanical data	51
Table 22.	Ordering information scheme	52
Table 23.	Document revision history	53

List of figures

Figure 1.	Logic diagram	6
Figure 2.	SO8, VFQFPN and VDFPN connections	7
Figure 3.	SO16 connections	7
Figure 4.	Bus master and memory devices on the SPI bus	10
Figure 5.	SPI modes supported	11
Figure 6.	Hold condition activation	15
Figure 7.	Block diagram	16
Figure 8.	Write Enable (WREN) instruction sequence	19
Figure 9.	Write Disable (WRDI) instruction sequence	20
Figure 10.	Read Identification (RDID) instruction sequence and data-out sequence	21
Figure 11.	Read Status Register (RDSR) instruction sequence and data-out sequence	23
Figure 12.	Write Status Register (WRSR) instruction sequence	24
Figure 13.	Read Data Bytes (READ) instruction sequence and data-out sequence	26
Figure 14.	Read Data Bytes at Higher Speed (FAST_READ) instruction sequence and data-out sequence	27
Figure 15.	Page Program (PP) instruction sequence	29
Figure 16.	Sector Erase (SE) instruction sequence	30
Figure 17.	Bulk Erase (BE) instruction sequence	31
Figure 18.	Deep Power-down (DP) instruction sequence	32
Figure 19.	Release from Deep Power-down and Read Electronic Signature (RES) instruction sequence and data-out sequence	34
Figure 20.	Release from Deep Power-down (RES) instruction sequence	34
Figure 21.	Power-up timing	36
Figure 22.	AC measurement I/O waveform	38
Figure 23.	Serial input timing	43
Figure 24.	Write Protect setup and hold timing during WRSR when SRWD = 1	44
Figure 25.	Hold timing	44
Figure 26.	Output timing	45
Figure 27.	VFQFPN8 (MLP8) 8-lead very thin fine pitch quad flat package no lead, 6 × 5 mm, package outline	46
Figure 28.	VDFPN8 (MLP8) 8-lead very thin dual flat package no lead, 8 × 6 mm, package outline	48
Figure 29.	SO8N – 8 lead plastic small outline, 150 mils body width, package outline	49
Figure 30.	SO8W – 8 lead plastic small outline, 208 mils body width, package outline	50
Figure 31.	SO16 wide – 16-lead plastic small outline, 300 mils body width, package outline	51

1 Description

The M25P16 is a 16 Mbit (2 Mbit × 8) serial Flash memory, with advanced write protection mechanisms, accessed by a high speed SPI-compatible bus.

The memory can be programmed 1 to 256 bytes at a time, using the Page Program instruction.

The memory is organized as 32 sectors, each containing 256 pages. Each page is 256 bytes wide. Thus, the whole memory can be viewed as consisting of 8192 pages, or 2 097 152 bytes.

The whole memory can be erased using the Bulk Erase instruction, or a sector at a time, using the Sector Erase instruction.

Figure 1. Logic diagram

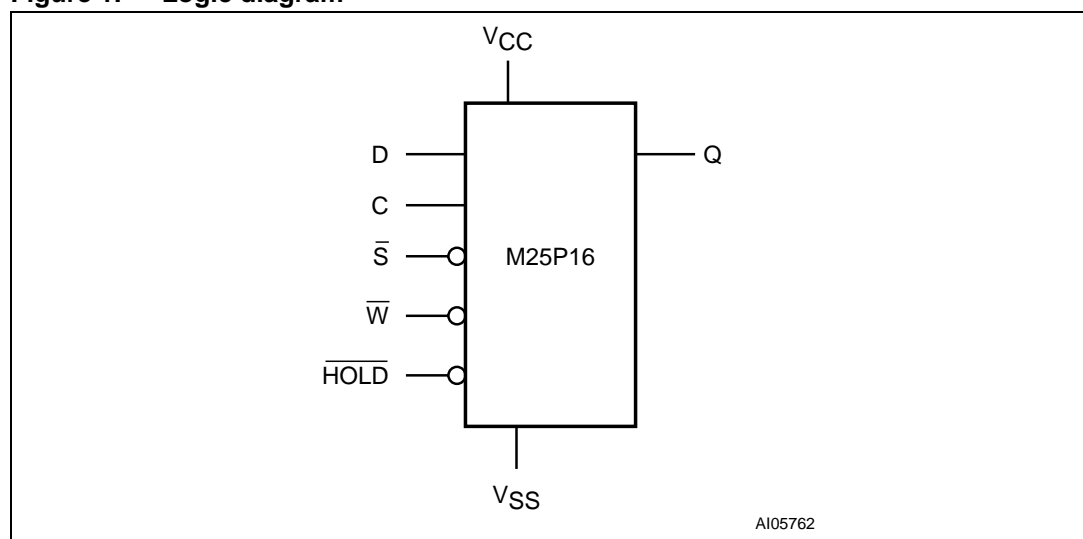
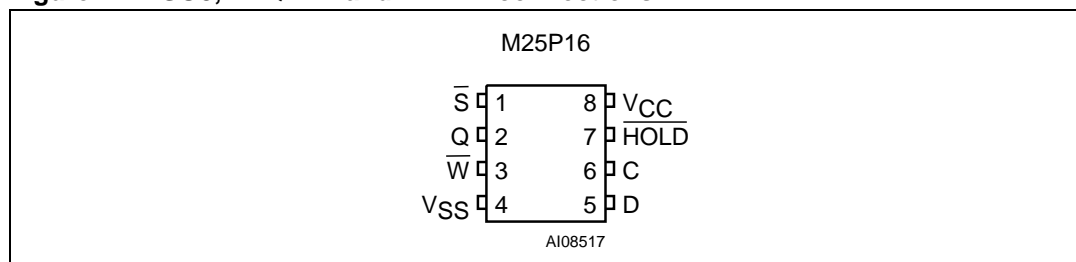

Table 1. Signal names

Signal name	Function	Direction
C	Serial Clock	Input
D	Serial Data input	Input
Q	Serial Data output	Output
\bar{S}	Chip Select	Input
\bar{W}	Write Protect	Input
\overline{HOLD}	Hold	Input
V _{CC}	Supply voltage	
V _{SS}	Ground	

Figure 2. SO8, VFQFPN and VDFPN connections



1. There is an exposed central pad on the underside of the VFQFPN package. This is pulled, internally, to V_{SS} , and must not be allowed to be connected to any other voltage or signal line on the PCB.
2. See [Package mechanical](#) section for package dimensions, and how to identify pin-1.

Figure 3. SO16 connections

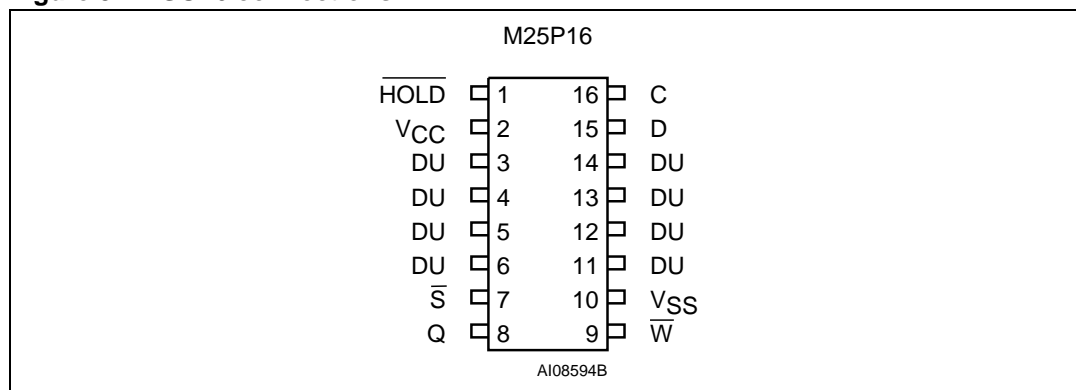

1. DU = Don't use
2. See [Package mechanical](#) section for package dimensions, and how to identify pin-1.

2 Signal description

2.1 Serial Data output (Q)

This output signal is used to transfer data serially out of the device. Data is shifted out on the falling edge of Serial Clock (C).

2.2 Serial Data input (D)

This input signal is used to transfer data serially into the device. It receives instructions, addresses, and the data to be programmed. Values are latched on the rising edge of Serial Clock (C).

2.3 Serial Clock (C)

This input signal provides the timing of the serial interface. Instructions, addresses, or data present at Serial Data input (D) are latched on the rising edge of Serial Clock (C). Data on Serial Data output (Q) changes after the falling edge of Serial Clock (C).

2.4 Chip Select (\overline{S})

When this input signal is High, the device is deselected and Serial Data output (Q) is at high impedance. Unless an internal Program, Erase or Write Status Register cycle is in progress, the device will be in the Standby mode (this is not the Deep Power-down mode). Driving Chip Select (\overline{S}) Low selects the device, placing it in the Active Power mode.

After power-up, a falling edge on Chip Select (\overline{S}) is required prior to the start of any instruction.

2.5 Hold (\overline{HOLD})

The Hold (\overline{HOLD}) signal is used to pause any serial communications with the device without deselecting the device.

During the Hold condition, the Serial Data output (Q) is high impedance, and Serial Data input (D) and Serial Clock (C) are Don't care.

To start the Hold condition, the device must be selected, with Chip Select (\overline{S}) driven Low.

2.6 Write Protect (\overline{W})

The main purpose of this input signal is to freeze the size of the area of memory that is protected against program or erase instructions (as specified by the values in the BP2, BP1 and BP0 bits of the Status Register).

2.7 V_{CC} supply voltage

V_{CC} is the supply voltage.

2.8 V_{SS} ground

V_{SS} is the reference for the V_{CC} supply voltage.

3 SPI modes

These devices can be driven by a microcontroller with its SPI peripheral running in either of the two following modes:

- CPOL=0, CPHA=0
- CPOL=1, CPHA=1

For these two modes, input data is latched in on the rising edge of Serial Clock (C), and output data is available from the falling edge of Serial Clock (C).

The difference between the two modes, as shown in *Figure 5*, is the clock polarity when the bus master is in Standby mode and not transferring data:

- C remains at 0 for (CPOL=0, CPHA=0)
- C remains at 1 for (CPOL=1, CPHA=1)

Figure 4. Bus master and memory devices on the SPI bus

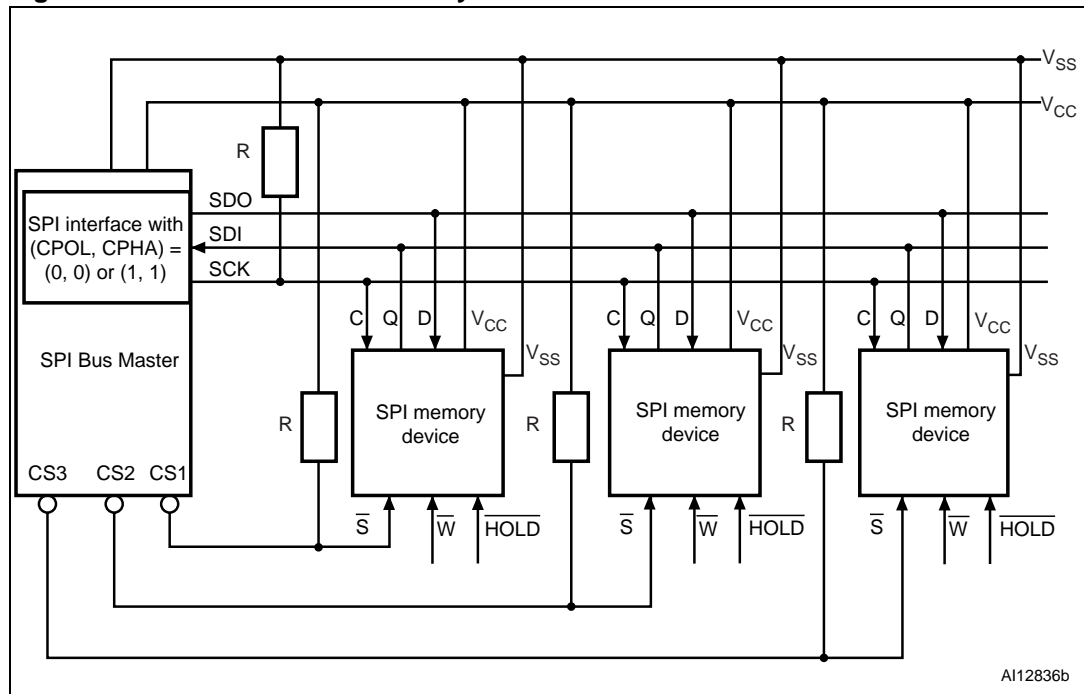

1. The Write Protect (\overline{W}) and Hold (\overline{HOLD}) signals should be driven, High or Low as appropriate.

Figure 4 shows an example of three devices connected to an MCU, on an SPI bus. Only one device is selected at a time, so only one device drives the Serial Data output (Q) line at a time, the other devices are high impedance. Resistors R (represented in *Figure 4*) ensure that the M25P16 is not selected if the Bus Master leaves the \overline{S} line in the high impedance state. As the Bus Master may enter a state where all inputs/outputs are in high impedance at the same time (for example, when the Bus Master is reset), the clock line (C) must be connected to an external pull-down resistor so that, when all inputs/outputs become high impedance, the \overline{S} line is pulled High while the C line is pulled Low (thus ensuring that \overline{S} and C do not become High at the same time, and so, that the t_{SHCH} requirement is met). The typical value of R is 100 k Ω , assuming that the time constant $R \cdot C_p$ (C_p = parasitic capacitance of the bus line) is shorter than the time during which the Bus Master leaves the SPI bus in high impedance.

Example: $C_p = 50 \text{ pF}$, that is $R \cdot C_p = 5 \text{ }\mu\text{s} \Leftrightarrow$ the application must ensure that the Bus Master never leaves the SPI bus in the high impedance state for a time period shorter than $5 \text{ }\mu\text{s}$.

Figure 5. SPI modes supported

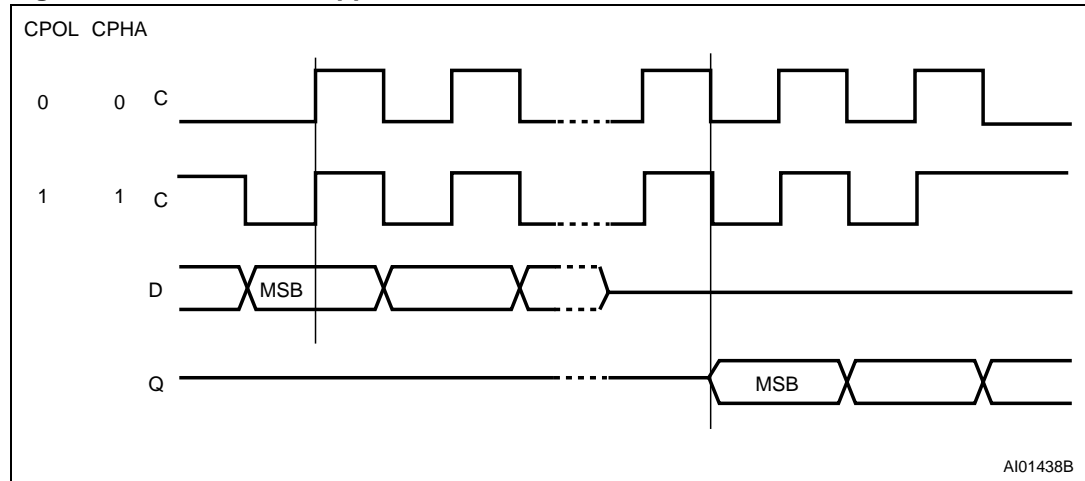

4 Operating features

4.1 Page programming

To program one data byte, two instructions are required: Write Enable (WREN), which is one byte, and a Page Program (PP) sequence, which consists of four bytes plus data. This is followed by the internal Program cycle (of duration t_{PP}).

To spread this overhead, the Page Program (PP) instruction allows up to 256 bytes to be programmed at a time (changing bits from 1 to 0), provided that they lie in consecutive addresses on the same page of memory.

For optimized timings, it is recommended to use the Page Program (PP) instruction to program all consecutive targeted bytes in a single sequence versus using several Page Program (PP) sequences with each containing only a few bytes (see [Page Program \(PP\)](#)).

4.2 Sector Erase and Bulk Erase

The Page Program (PP) instruction allows bits to be reset from 1 to 0. Before this can be applied, the bytes of memory need to have been erased to all 1s (FFh). This can be achieved either a sector at a time, using the Sector Erase (SE) instruction, or throughout the entire memory, using the Bulk Erase (BE) instruction. This starts an internal Erase cycle (of duration t_{SE} or t_{BE}).

The Erase instruction must be preceded by a Write Enable (WREN) instruction.

4.3 Polling during a Write, Program or Erase cycle

A further improvement in the time to Write Status Register (WRSR), Program (PP) or Erase (SE or BE) can be achieved by not waiting for the worst case delay (t_W , t_{PP} , t_{SE} , or t_{BE}). The Write In Progress (WIP) bit is provided in the Status Register so that the application program can monitor its value, polling it to establish when the previous Write cycle, Program cycle or Erase cycle is complete.

4.4 Active Power, Standby Power and Deep Power-down modes

When Chip Select (\overline{S}) is Low, the device is selected, and in the Active Power mode.

When Chip Select (\overline{S}) is High, the device is deselected, but could remain in the Active Power mode until all internal cycles have completed (Program, Erase, Write Status Register). The device then goes in to the Standby Power mode. The device consumption drops to I_{CC1} .

The Deep Power-down mode is entered when the specific instruction (the Deep Power-down (DP) instruction) is executed. The device consumption drops further to I_{CC2} . The device remains in this mode until another specific instruction (the Release from Deep Power-down and Read Electronic Signature (RES) instruction) is executed.

While in the Deep Power-down mode, the device ignores all Write, Program and Erase instructions (see [Deep Power-down \(DP\)](#)). This can be used as an extra software protection mechanism, when the device is not in active use, to protect the device from inadvertent Write, Program or Erase instructions.

4.5 Status Register

The Status Register contains a number of status and control bits that can be read or set (as appropriate) by specific instructions. See [Section 6.4: Read Status Register \(RDSR\)](#) for a detailed description of the Status Register bits.

4.6 Protection modes

The environments where non-volatile memory devices are used can be very noisy. No SPI device can operate correctly in the presence of excessive noise. To help combat this, the M25P16 features the following data protection mechanisms:

- Power on reset and an internal timer (t_{PUW}) can provide protection against inadvertent changes while the power supply is outside the operating specification
- Program, Erase and Write Status Register instructions are checked that they consist of a number of clock pulses that is a multiple of eight, before they are accepted for execution
- All instructions that modify data must be preceded by a Write Enable (WREN) instruction to set the Write Enable Latch (WEL) bit. This bit is returned to its reset state by the following events:
 - Power-up
 - Write Disable (WRDI) instruction completion
 - Write Status Register (WRSR) instruction completion
 - Page Program (PP) instruction completion
 - Sector Erase (SE) instruction completion
 - Bulk Erase (BE) instruction completion
- The Block Protect (BP2, BP1, BP0) bits allow part of the memory to be configured as read-only. This is the software protected mode (SPM)
- The Write Protect (\overline{WP}) signal allows the Block Protect (BP2, BP1, BP0) bits and Status Register Write Disable (SRWD) bit to be protected. This is the hardware protected mode (HPM)
- In addition to the low power consumption feature, the Deep Power-down mode offers extra software protection, as all Write, Program and Erase instructions are ignored.

Table 2. Protected area sizes

Status Register content			Memory content	
BP2 bit	BP1 bit	BP0 bit	Protected area	Unprotected area
0	0	0	none	All sectors ⁽¹⁾ (32 sectors: 0 to 31)
0	0	1	Upper 32nd (Sector 31)	Lower 31/32nds (31 sectors: 0 to 30)
0	1	0	Upper sixteenth (2 sectors: 30 and 31)	Lower 15/16ths (30 sectors: 0 to 29)
0	1	1	Upper eighth (4 sectors: 28 to 31)	Lower seven-eighths (28 sectors: 0 to 27)
1	0	0	Upper quarter (8 sectors: 24 to 31)	Lower three-quarters (24 sectors: 0 to 23)
1	0	1	Upper half (16 sectors: 16 to 31)	Lower half (16 sectors: 0 to 15)
1	1	0	All sectors (32 sectors: 0 to 31)	none
1	1	1	All sectors (32 sectors: 0 to 31)	none

1. The device is ready to accept a Bulk Erase instruction if, and only if, all Block Protect (BP2, BP1, BP0) are 0.

4.7 Hold condition

The Hold ($\overline{\text{HOLD}}$) signal is used to pause any serial communications with the device without resetting the clocking sequence. However, taking this signal Low does not terminate any Write Status Register, Program or Erase cycle that is currently in progress.

To enter the Hold condition, the device must be selected, with Chip Select ($\overline{\text{S}}$) Low.

The Hold condition starts on the falling edge of the Hold ($\overline{\text{HOLD}}$) signal, provided that this coincides with Serial Clock (C) being Low (as shown in [Figure 6](#)).

The Hold condition ends on the rising edge of the Hold ($\overline{\text{HOLD}}$) signal, provided that this coincides with Serial Clock (C) being Low.

If the falling edge does not coincide with Serial Clock (C) being Low, the Hold condition starts after Serial Clock (C) next goes Low. Similarly, if the rising edge does not coincide with Serial Clock (C) being Low, the Hold condition ends after Serial Clock (C) next goes Low (this is shown in [Figure 6](#)).

During the Hold condition, the Serial Data output (Q) is high impedance, and Serial Data input (D) and Serial Clock (C) are Don't care.

Normally, the device is kept selected, with Chip Select ($\overline{\text{S}}$) driven Low, for the whole duration of the Hold condition. This is to ensure that the state of the internal logic remains unchanged from the moment of entering the Hold condition.

If Chip Select ($\overline{\text{S}}$) goes High while the device is in the Hold condition, this has the effect of resetting the internal logic of the device. To restart communication with the device, it is necessary to drive Hold ($\overline{\text{HOLD}}$) High, and then to drive Chip Select ($\overline{\text{S}}$) Low. This prevents the device from going back to the Hold condition.

Figure 6. Hold condition activation

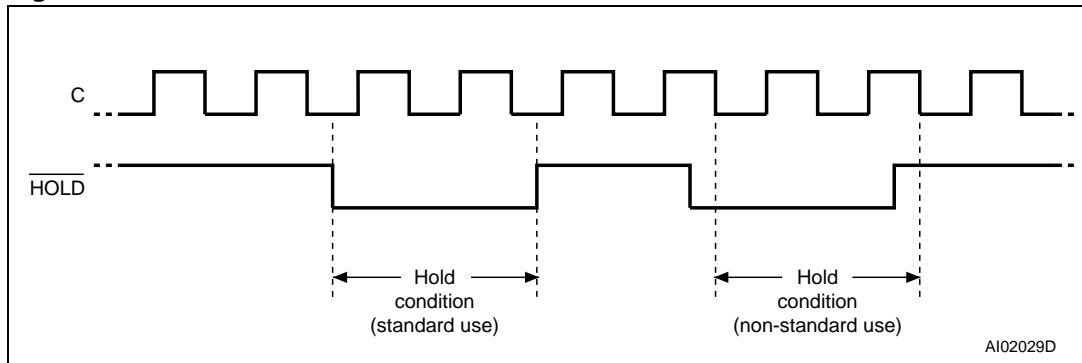

5 Memory organization

The memory is organized as:

- 2 097 152 bytes (8 bits each)
- 32 sectors (512 Kbits, 65536 bytes each)
- 8192 pages (256 bytes each).

Each page can be individually programmed (bits are programmed from 1 to 0). The device is sector or bulk erasable (bits are erased from 0 to 1) but not page erasable.

Figure 7. Block diagram

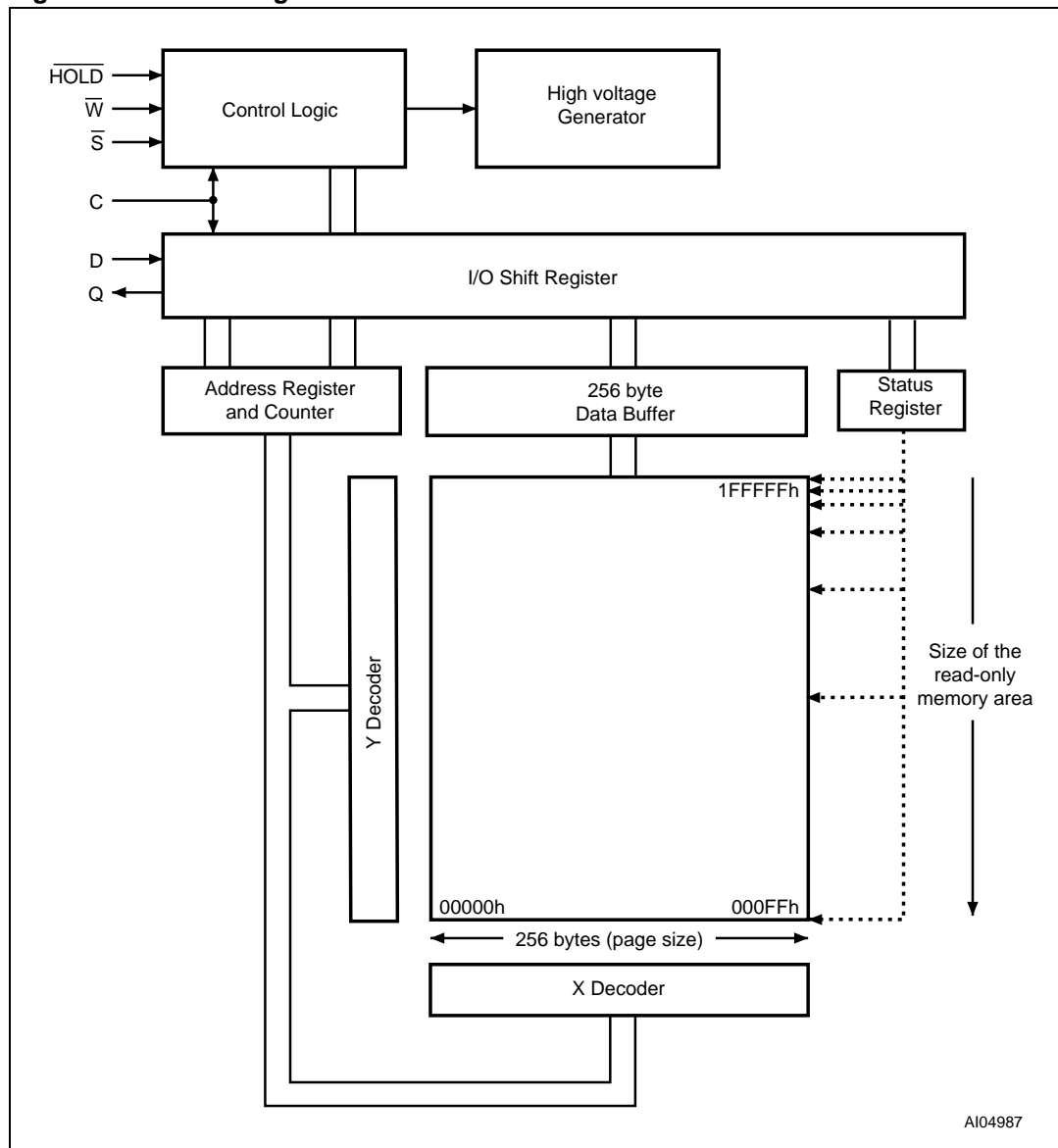

Table 3. Memory organization

Sector	Address range	
31	1F0000h	1FFFFFFh
30	1E0000h	1EFFFFFFh
29	1D0000h	1DFFFFFFh
28	1C0000h	1CFFFFFFh
27	1B0000h	1BFFFFFFh
26	1A0000h	1AFFFFFFh
25	190000h	19FFFFFFh
24	180000h	18FFFFFFh
23	170000h	17FFFFFFh
22	160000h	16FFFFFFh
21	150000h	15FFFFFFh
20	140000h	14FFFFFFh
19	130000h	13FFFFFFh
18	120000h	12FFFFFFh
17	110000h	11FFFFFFh
16	100000h	10FFFFFFh
15	0F0000h	0FFFFFFh
14	0E0000h	0EFFFFFFh
13	0D0000h	0DFFFFFFh
12	0C0000h	0CFFFFFFh
11	0B0000h	0BFFFFFFh
10	0A0000h	0AFFFFFFh
9	090000h	09FFFFFFh
8	080000h	08FFFFFFh
7	070000h	07FFFFFFh
6	060000h	06FFFFFFh
5	050000h	05FFFFFFh
4	040000h	04FFFFFFh
3	030000h	03FFFFFFh
2	020000h	02FFFFFFh
1	010000h	01FFFFFFh
0	000000h	00FFFFFFh

6 Instructions

All instructions, addresses and data are shifted in and out of the device, most significant bit first.

Serial Data input (D) is sampled on the first rising edge of Serial Clock (C) after Chip Select (\overline{S}) is driven Low. Then, the one-byte instruction code must be shifted in to the device, most significant bit first, on Serial Data input (D), each bit being latched on the rising edges of Serial Clock (C).

The instruction set is listed in [Table 4](#).

Every instruction sequence starts with a one-byte instruction code. Depending on the instruction, this might be followed by address bytes, or by data bytes, or by both or none.

In the case of a Read Data Bytes (READ), Read Data Bytes at Higher Speed (FAST_READ), Read Status Register (RDSR), Read Identification (RDID) or Release from Deep Power-down, and Read Electronic Signature (RES) instruction, the shifted-in instruction sequence is followed by a data-out sequence. Chip Select (\overline{S}) can be driven High after any bit of the data-out sequence is being shifted out.

In the case of a Page Program (PP), Sector Erase (SE), Bulk Erase (BE), Write Status Register (WRSR), Write Enable (WREN), Write Disable (WRDI) or Deep Power-down (DP) instruction, Chip Select (\overline{S}) must be driven High exactly at a byte boundary, otherwise the instruction is rejected, and is not executed. That is, Chip Select (\overline{S}) must be driven High when the number of clock pulses after Chip Select (\overline{S}) being driven Low is an exact multiple of eight.

All attempts to access the memory array during a Write Status Register cycle, Program cycle or Erase cycle are ignored, and the internal Write Status Register cycle, Program cycle or Erase cycle continues unaffected.

Note: Output Hi-Z is defined as the point where data out is no longer driven.

Table 4. Instruction set

Instruction	Description	One-byte instruction code		Address bytes	Dummy bytes	Data bytes
WREN	Write Enable	0000 0110	06h	0	0	0
WRDI	Write Disable	0000 0100	04h	0	0	0
RDID	Read Identification	1001 1111	9Fh	0	0	1 to 20
RDSR	Read Status Register	0000 0101	05h	0	0	1 to ∞
WRSR	Write Status Register	0000 0001	01h	0	0	1
READ	Read Data Bytes	0000 0011	03h	3	0	1 to ∞
FAST_READ	Read Data Bytes at Higher Speed	0000 1011	0Bh	3	1	1 to ∞
PP	Page Program	0000 0010	02h	3	0	1 to 256
SE	Sector Erase	1101 1000	D8h	3	0	0
BE	Bulk Erase	1100 0111	C7h	0	0	0
DP	Deep Power-down	1011 1001	B9h	0	0	0
RES	Release from Deep Power-down, and Read Electronic Signature	1010 1011	ABh	0	3	1 to ∞
	Release from Deep Power-down			0	0	0

6.1 Write Enable (WREN)

The Write Enable (WREN) instruction ([Figure 8](#)) sets the Write Enable Latch (WEL) bit.

The Write Enable Latch (WEL) bit must be set prior to every Page Program (PP), Sector Erase (SE), Bulk Erase (BE) and Write Status Register (WRSR) instruction.

The Write Enable (WREN) instruction is entered by driving Chip Select (\bar{S}) Low, sending the instruction code, and then driving Chip Select (\bar{S}) High.

Figure 8. Write Enable (WREN) instruction sequence

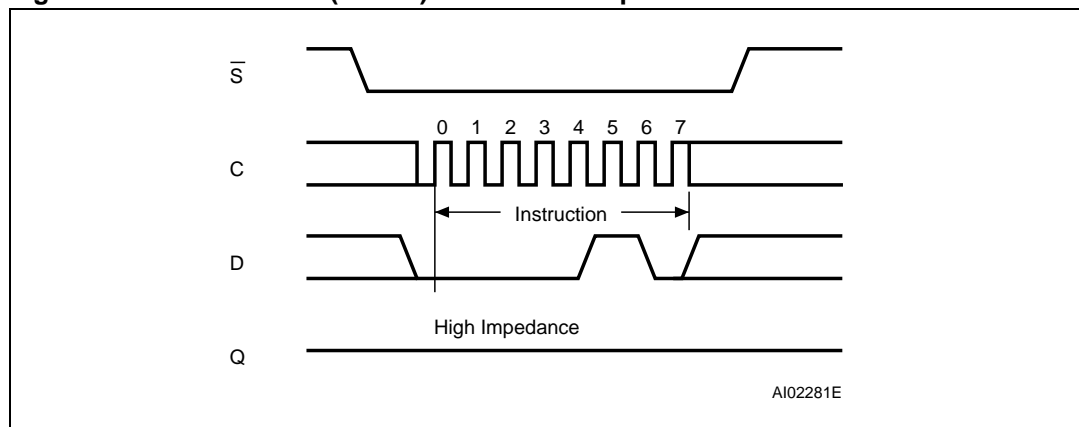

6.2 Write Disable (WRDI)

The Write Disable (WRDI) instruction (*Figure 9*) resets the Write Enable Latch (WEL) bit.

The Write Disable (WRDI) instruction is entered by driving Chip Select (\bar{S}) Low, sending the instruction code, and then driving Chip Select (\bar{S}) High.

The Write Enable Latch (WEL) bit is reset under the following conditions:

- Power-up
- Write Disable (WRDI) instruction completion
- Write Status Register (WRSR) instruction completion
- Page Program (PP) instruction completion
- Sector Erase (SE) instruction completion
- Bulk Erase (BE) instruction completion

Figure 9. Write Disable (WRDI) instruction sequence

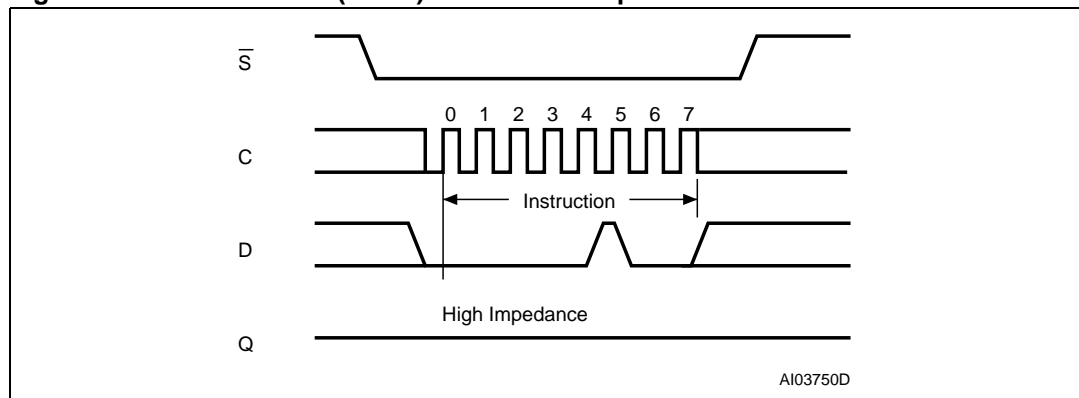

6.3 Read Identification (RDID)

The Read Identification (RDID) instruction allows to read the device identification data:

- Manufacturer identification (1 byte)
- Device identification (2 bytes)
- A Unique ID code (UID) (17 bytes, of which 16 available upon customer request).

The manufacturer identification is assigned by JEDEC, and has the value 20h for STMicroelectronics. The device identification is assigned by the device manufacturer, and indicates the memory type in the first byte (20h), and the memory capacity of the device in the second byte (15h). The UID contains the length of the following data in the first byte (set to 10h), and 16 bytes of the optional Customized Factory Data (CFD) content. The CFD bytes are read-only and can be programmed with customers data upon their demand. If the customers do not make requests, the devices are shipped with all the CFD bytes programmed to zero (00h).

Any Read Identification (RDID) instruction while an Erase or Program cycle is in progress, is not decoded, and has no effect on the cycle that is in progress.

The device is first selected by driving Chip Select (\bar{S}) Low. Then, the 8-bit instruction code for the instruction is shifted in. After this, the 24-bit device identification, stored in the memory, the 8-bit CFD length followed by 16 bytes of CFD content will be shifted out on Serial Data output (Q). Each bit is shifted out during the falling edge of Serial Clock (C).

The instruction sequence is shown in *Figure 10*.

The Read Identification (RDID) instruction is terminated by driving Chip Select (\bar{S}) High at any time during data output.

When Chip Select (\bar{S}) is driven High, the device is put in the Standby Power mode. Once in the Standby Power mode, the device waits to be selected, so that it can receive, decode and execute instructions.

Table 5. Read Identification (RDID) data-out sequence

Manufacturer identification	Device identification		UID	
	Memory type	Memory capacity	CFD length	CFD content
20h	20h	15h	10h	16 bytes

Figure 10. Read Identification (RDID) instruction sequence and data-out sequence

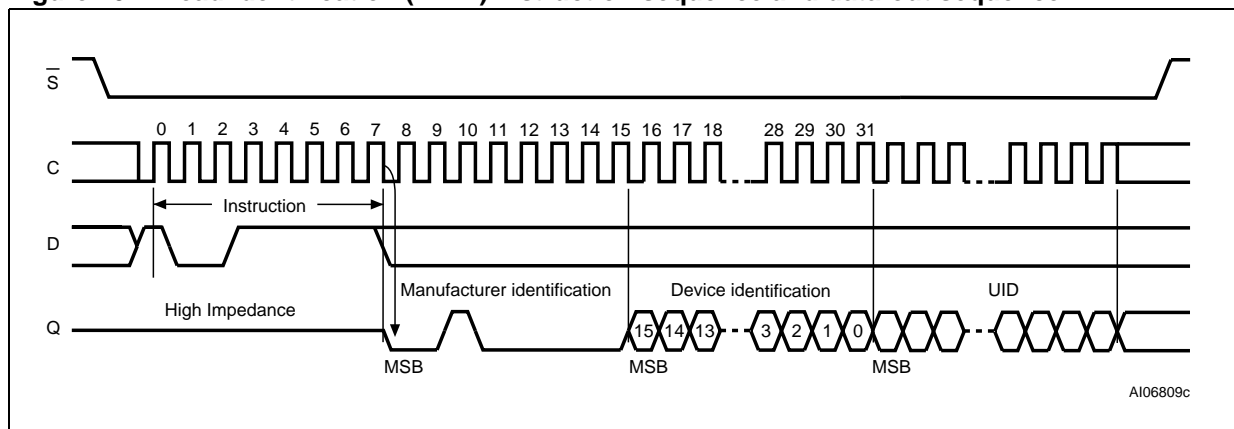

6.4 Read Status Register (RDSR)

The Read Status Register (RDSR) instruction allows the Status Register to be read. The Status Register may be read at any time, even while a Program, Erase or Write Status Register cycle is in progress. When one of these cycles is in progress, it is recommended to check the Write In Progress (WIP) bit before sending a new instruction to the device. It is also possible to read the Status Register continuously, as shown in [Figure 11](#).

Table 6. Status Register format

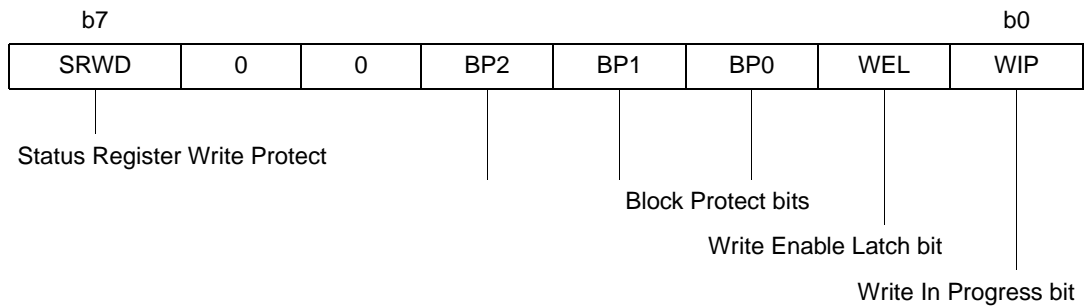

The status and control bits of the Status Register are as follows:

6.4.1 WIP bit

The Write In Progress (WIP) bit indicates whether the memory is busy with a Write Status Register, Program or Erase cycle. When set to '1', such a cycle is in progress, when reset to '0' no such cycle is in progress.

6.4.2 WEL bit

The Write Enable Latch (WEL) bit indicates the status of the internal Write Enable Latch. When set to '1' the internal Write Enable Latch is set, when set to '0' the internal Write Enable Latch is reset and no Write Status Register, Program or Erase instruction is accepted.

6.4.3 BP2, BP1, BP0 bits

The Block Protect (BP2, BP1, BP0) bits are non-volatile. They define the size of the area to be software protected against Program and Erase instructions. These bits are written with the Write Status Register (WRSR) instruction. When one or more of the Block Protect (BP2, BP1, BP0) bits is set to '1', the relevant memory area (as defined in [Table 2](#)) becomes protected against Page Program (PP) and Sector Erase (SE) instructions. The Block Protect (BP2, BP1, BP0) bits can be written provided that the Hardware Protected mode has not been set. The Bulk Erase (BE) instruction is executed if, and only if, all Block Protect (BP2, BP1, BP0) bits are 0.

6.4.4 SRWD bit

The Status Register Write Disable (SRWD) bit is operated in conjunction with the Write Protect (\overline{WP}) signal. The Status Register Write Disable (SRWD) bit and Write Protect (\overline{WP}) signal allow the device to be put in the Hardware Protected mode (when the Status Register Write Disable (SRWD) bit is set to '1', and Write Protect (\overline{WP}) is driven Low). In this mode, the non-volatile bits of the Status Register (SRWD, BP2, BP1, BP0) become read-only bits and the Write Status Register (WRSR) instruction is no longer accepted for execution.

Figure 11. Read Status Register (RDSR) instruction sequence and data-out sequence

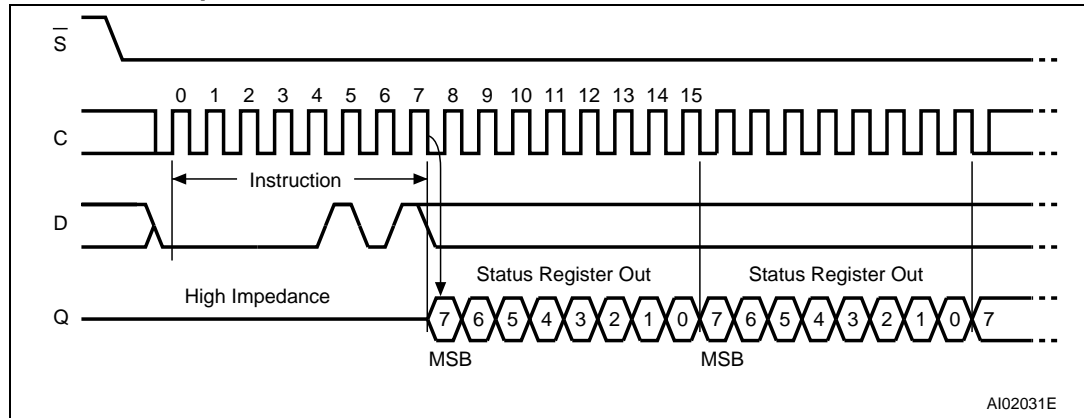

6.5 Write Status Register (WRSR)

The Write Status Register (WRSR) instruction allows new values to be written to the Status Register. Before it can be accepted, a Write Enable (WREN) instruction must previously have been executed. After the Write Enable (WREN) instruction has been decoded and executed, the device sets the Write Enable Latch (WEL).

The Write Status Register (WRSR) instruction is entered by driving Chip Select (\bar{S}) Low, followed by the instruction code and the data byte on Serial Data input (D).

The instruction sequence is shown in [Figure 12](#).

The Write Status Register (WRSR) instruction has no effect on b6, b5, b1 and b0 of the Status Register. b6 and b5 are always read as 0.

Chip Select (\bar{S}) must be driven High after the eighth bit of the data byte has been latched in. If not, the Write Status Register (WRSR) instruction is not executed. As soon as Chip Select (\bar{S}) is driven High, the self-timed Write Status Register cycle (whose duration is t_{W}) is initiated. While the Write Status Register cycle is in progress, the Status Register may still be read to check the value of the Write In Progress (WIP) bit. The Write In Progress (WIP) bit is 1 during the self-timed Write Status Register cycle, and is 0 when it is completed. When the cycle is completed, the Write Enable Latch (WEL) is reset.

The Write Status Register (WRSR) instruction allows the user to change the values of the Block Protect (BP2, BP1, BP0) bits, to define the size of the area that is to be treated as read-only, as defined in [Table 2](#). The Write Status Register (WRSR) instruction also allows the user to set or reset the Status Register Write Disable (SRWD) bit in accordance with the Write Protect (\bar{W}) signal. The Status Register Write Disable (SRWD) bit and Write Protect (\bar{W}) signal allow the device to be put in the Hardware Protected mode (HPM). The Write Status Register (WRSR) instruction is not executed once the Hardware Protected mode (HPM) is entered.

Figure 12. Write Status Register (WRSR) instruction sequence

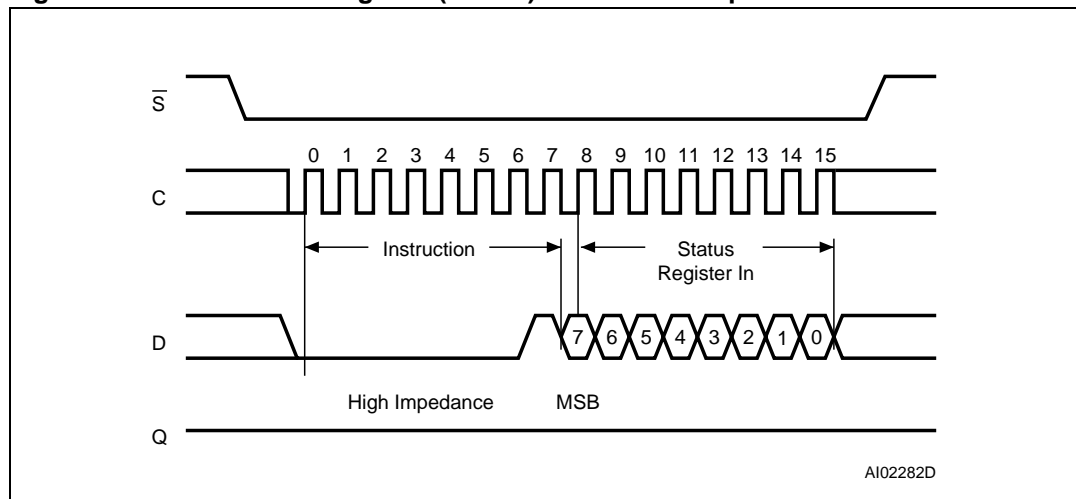

Table 7. Protection modes

\overline{W} signal	SRWD bit	Mode	Write Protection of the Status Register	Memory content	
				Protected area ⁽¹⁾	Unprotected area ⁽¹⁾
1	0	Software Protected mode (SPM)	Status Register is writable (if the WREN instruction has set the WEL bit)	Protected against Page Program, Sector Erase and Bulk Erase	Ready to accept Page Program and Sector Erase instructions
0	0		The values in the SRWD, BP2, BP1 and BP0 bits can be changed		
1	1	Hardware Protected mode (HPM)	Status Register is Hardware write protected	Protected against Page Program, Sector Erase and Bulk Erase	Ready to accept Page Program and Sector Erase instructions
0	1		The values in the SRWD, BP2, BP1 and BP0 bits cannot be changed		

1. As defined by the values in the Block Protect (BP2, BP1, BP0) bits of the Status Register, as shown in [Table 6](#).

The protection features of the device are summarized in [Table 7](#).

When the Status Register Write Disable (SRWD) bit of the Status Register is 0 (its initial delivery state), it is possible to write to the Status Register provided that the Write Enable Latch (WEL) bit has previously been set by a Write Enable (WREN) instruction, regardless of the whether Write Protect (\overline{W}) is driven High or Low.

When the Status Register Write Disable (SRWD) bit of the Status Register is set to '1', two cases need to be considered, depending on the state of Write Protect (\overline{W}):

- If Write Protect (\overline{W}) is driven High, it is possible to write to the Status Register provided that the Write Enable Latch (WEL) bit has previously been set by a Write Enable (WREN) instruction
- If Write Protect (\overline{W}) is driven Low, it is not possible to write to the Status Register even if the Write Enable Latch (WEL) bit has previously been set by a Write Enable (WREN) instruction (attempts to write to the Status Register are rejected, and are not accepted for execution). As a consequence, all the data bytes in the memory area that are software protected (SPM) by the Block Protect (BP2, BP1, BP0) bits of the Status Register, are also hardware protected against data modification.

Regardless of the order of the two events, the Hardware Protected mode (HPM) can be entered:

- by setting the Status Register Write Disable (SRWD) bit after driving Write Protect (\overline{W}) Low
- or by driving Write Protect (\overline{W}) Low after setting the Status Register Write Disable (SRWD) bit.

The only way to exit the Hardware Protected mode (HPM) once entered is to pull Write Protect (\overline{W}) High.

If Write Protect (\overline{W}) is permanently tied High, the Hardware Protected mode (HPM) can never be activated, and only the Software Protected mode (SPM), using the Block Protect (BP2, BP1, BP0) bits of the Status Register, can be used.

6.6 Read Data Bytes (READ)

The device is first selected by driving Chip Select (\bar{S}) Low. The instruction code for the Read Data Bytes (READ) instruction is followed by a 3-byte address (A23-A0), each bit being latched-in during the rising edge of Serial Clock (C). Then the memory contents, at that address, is shifted out on Serial Data output (Q), each bit being shifted out, at a maximum frequency f_R , during the falling edge of Serial Clock (C).

The instruction sequence is shown in *Figure 13*.

The first byte addressed can be at any location. The address is automatically incremented to the next higher address after each byte of data is shifted out. The whole memory can, therefore, be read with a single Read Data Bytes (READ) instruction. When the highest address is reached, the address counter rolls over to 000000h, allowing the read sequence to be continued indefinitely.

The Read Data Bytes (READ) instruction is terminated by driving Chip Select (\bar{S}) High. Chip Select (\bar{S}) can be driven High at any time during data output. Any Read Data Bytes (READ) instruction, while an Erase, Program or Write cycle is in progress, is rejected without having any effects on the cycle that is in progress.

Figure 13. Read Data Bytes (READ) instruction sequence and data-out sequence

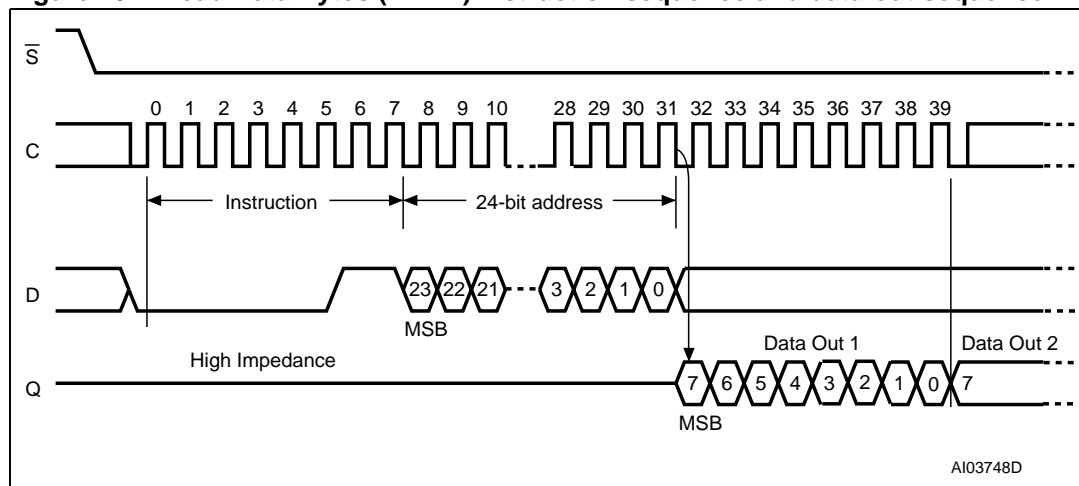

1. Address bits A23 to A21 are Don't care.

6.7 Read Data Bytes at Higher Speed (FAST_READ)

The device is first selected by driving Chip Select (\bar{S}) Low. The instruction code for the Read Data Bytes at Higher Speed (FAST_READ) instruction is followed by a 3-byte address (A23-A0) and a dummy byte, each bit being latched-in during the rising edge of Serial Clock (C). Then the memory contents, at that address, is shifted out on Serial Data output (Q), each bit being shifted out, at a maximum frequency f_C , during the falling edge of Serial Clock (C).

The instruction sequence is shown in *Figure 14*.

The first byte addressed can be at any location. The address is automatically incremented to the next higher address after each byte of data is shifted out. The whole memory can, therefore, be read with a single Read Data Bytes at Higher Speed (FAST_READ) instruction. When the highest address is reached, the address counter rolls over to 000000h, allowing the read sequence to be continued indefinitely.

The Read Data Bytes at Higher Speed (FAST_READ) instruction is terminated by driving Chip Select (\bar{S}) High. Chip Select (\bar{S}) can be driven High at any time during data output. Any Read Data Bytes at Higher Speed (FAST_READ) instruction, while an Erase, Program or Write cycle is in progress, is rejected without having any effects on the cycle that is in progress.

Figure 14. Read Data Bytes at Higher Speed (FAST_READ) instruction sequence and data-out sequence

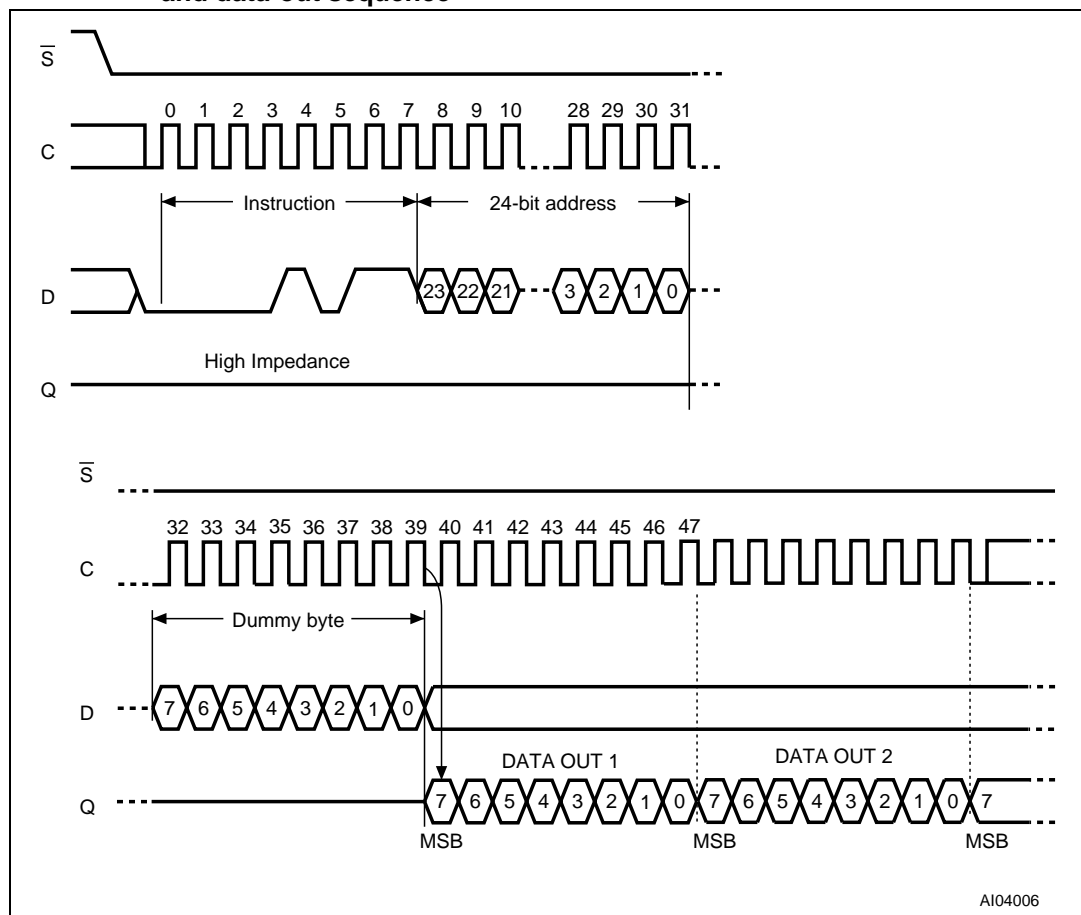

1. Address bits A23 to A21 are Don't care.

6.8 Page Program (PP)

The Page Program (PP) instruction allows bytes to be programmed in the memory (changing bits from 1 to 0). Before it can be accepted, a Write Enable (WREN) instruction must previously have been executed. After the Write Enable (WREN) instruction has been decoded, the device sets the Write Enable Latch (WEL).

The Page Program (PP) instruction is entered by driving Chip Select (\overline{S}) Low, followed by the instruction code, three address bytes and at least one data byte on Serial Data input (D). If the 8 least significant address bits (A7-A0) are not all zero, all transmitted data that goes beyond the end of the current page are programmed from the start address of the same page (from the address whose 8 least significant bits (A7-A0) are all zero). Chip Select (\overline{S}) must be driven Low for the entire duration of the sequence.

The instruction sequence is shown in [Figure 15](#).

If more than 256 bytes are sent to the device, previously latched data are discarded and the last 256 data bytes are guaranteed to be programmed correctly within the same page. If less than 256 data bytes are sent to device, they are correctly programmed at the requested addresses without having any effects on the other bytes of the same page.

For optimized timings, it is recommended to use the Page Program (PP) instruction to program all consecutive targeted bytes in a single sequence versus using several Page Program (PP) sequences with each containing only a few bytes.

Chip Select (\overline{S}) must be driven High after the eighth bit of the last data byte has been latched in, otherwise the Page Program (PP) instruction is not executed.

As soon as Chip Select (\overline{S}) is driven High, the self-timed Page Program cycle (whose duration is t_{pp}) is initiated. While the Page Program cycle is in progress, the Status Register may be read to check the value of the Write In Progress (WIP) bit. The Write In Progress (WIP) bit is 1 during the self-timed Page Program cycle, and is 0 when it is completed. At some unspecified time before the cycle is completed, the Write Enable Latch (WEL) bit is reset.

A Page Program (PP) instruction applied to a page which is protected by the Block Protect (BP2, BP1, BP0) bits (see [Table 2](#) and [Table 3](#)) is not executed.

Figure 15. Page Program (PP) instruction sequence

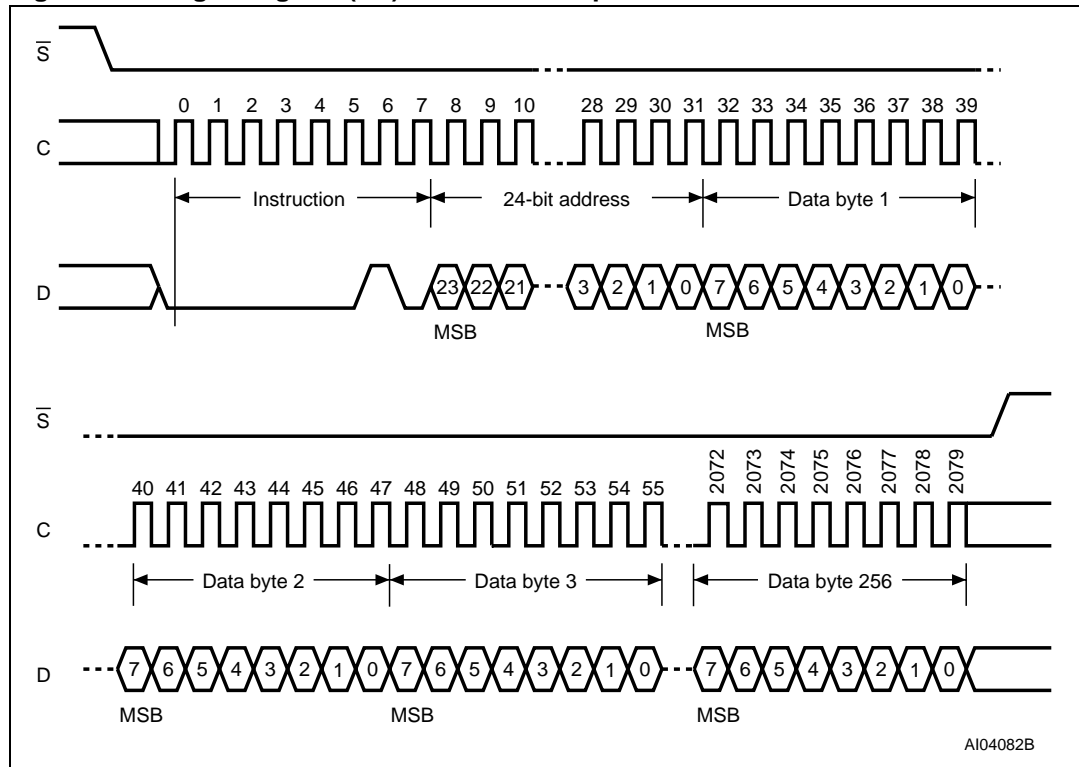

1. Address bits A23 to A21 are Don't care.

6.9 Sector Erase (SE)

The Sector Erase (SE) instruction sets to '1' (FFh) all bits inside the chosen sector. Before it can be accepted, a Write Enable (WREN) instruction must previously have been executed. After the Write Enable (WREN) instruction has been decoded, the device sets the Write Enable Latch (WEL).

The Sector Erase (SE) instruction is entered by driving Chip Select (\bar{S}) Low, followed by the instruction code, and three address bytes on Serial Data input (D). Any address inside the sector (see [Table 3](#)) is a valid address for the Sector Erase (SE) instruction. Chip Select (\bar{S}) must be driven Low for the entire duration of the sequence.

The instruction sequence is shown in [Figure 16](#).

Chip Select (\bar{S}) must be driven High after the eighth bit of the last address byte has been latched in, otherwise the Sector Erase (SE) instruction is not executed. As soon as Chip Select (\bar{S}) is driven High, the self-timed Sector Erase cycle (whose duration is t_{SE}) is initiated. While the Sector Erase cycle is in progress, the Status Register may be read to check the value of the Write In Progress (WIP) bit. The Write In Progress (WIP) bit is 1 during the self-timed Sector Erase cycle, and is 0 when it is completed. At some unspecified time before the cycle is completed, the Write Enable Latch (WEL) bit is reset.

A Sector Erase (SE) instruction applied to a page which is protected by the Block Protect (BP2, BP1, BP0) bits (see [Table 2](#) and [Table 3](#)) is not executed.

Figure 16. Sector Erase (SE) instruction sequence

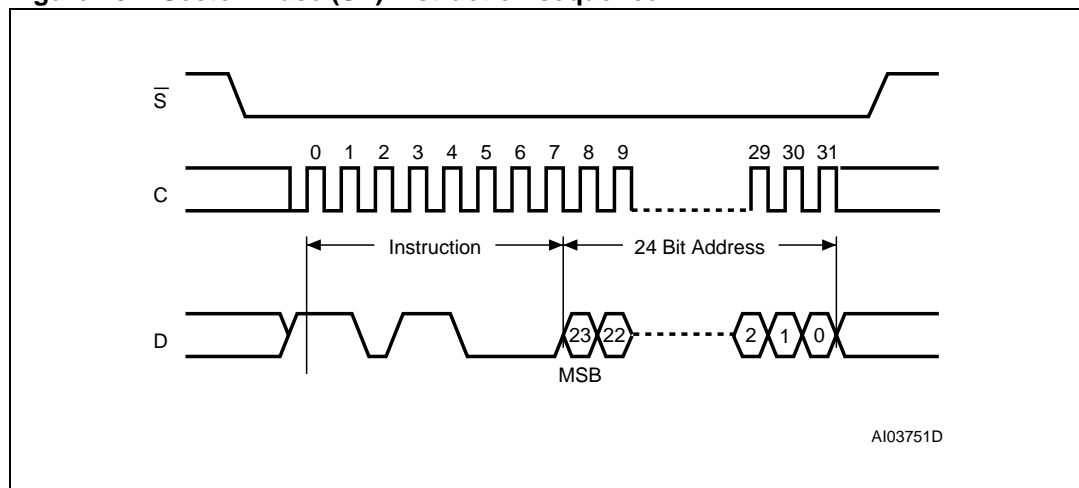

1. Address bits A23 to A21 are Don't care.

6.10 Bulk Erase (BE)

The Bulk Erase (BE) instruction sets all bits to '1' (FFh). Before it can be accepted, a Write Enable (WREN) instruction must previously have been executed. After the Write Enable (WREN) instruction has been decoded, the device sets the Write Enable Latch (WEL).

The Bulk Erase (BE) instruction is entered by driving Chip Select (\bar{S}) Low, followed by the instruction code on Serial Data input (D). Chip Select (\bar{S}) must be driven Low for the entire duration of the sequence.

The instruction sequence is shown in [Figure 17](#).

Chip Select (\bar{S}) must be driven High after the eighth bit of the instruction code has been latched in, otherwise the Bulk Erase instruction is not executed. As soon as Chip Select (\bar{S}) is driven High, the self-timed Bulk Erase cycle (whose duration is t_{BE}) is initiated. While the Bulk Erase cycle is in progress, the Status Register may be read to check the value of the Write In Progress (WIP) bit. The Write In Progress (WIP) bit is 1 during the self-timed Bulk Erase cycle, and is 0 when it is completed. At some unspecified time before the cycle is completed, the Write Enable Latch (WEL) bit is reset.

The Bulk Erase (BE) instruction is executed only if all Block Protect (BP2, BP1, BP0) bits are 0. The Bulk Erase (BE) instruction is ignored if one, or more, sectors are protected.

Figure 17. Bulk Erase (BE) instruction sequence

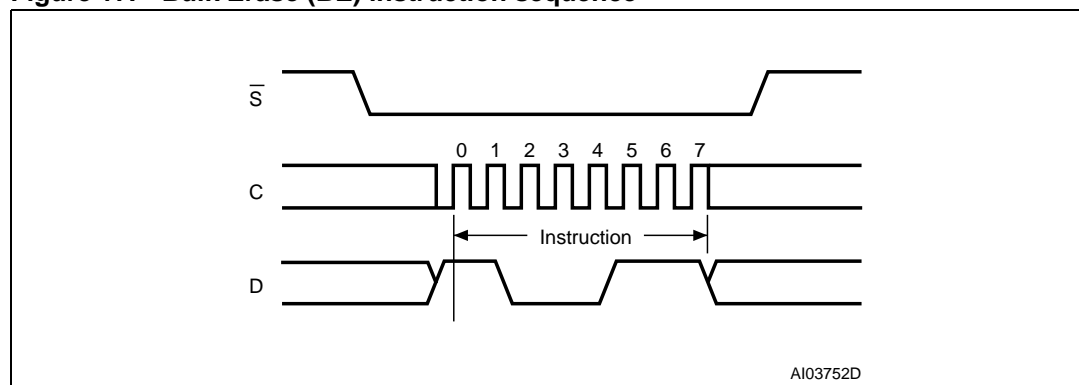

6.11 Deep Power-down (DP)

Executing the Deep Power-down (DP) instruction is the only way to put the device in the lowest consumption mode (the Deep Power-down mode). It can also be used as a software protection mechanism, while the device is not in active use, as in this mode, the device ignores all Write, Program and Erase instructions.

Driving Chip Select (\bar{S}) High deselects the device, and puts the device in the Standby mode (if there is no internal cycle currently in progress). But this mode is not the Deep Power-down mode. The Deep Power-down mode can only be entered by executing the Deep Power-down (DP) instruction, subsequently reducing the standby current (from I_{CC1} to I_{CC2} , as specified in [Table 14](#)).

To take the device out of Deep Power-down mode, the Release from Deep Power-down and Read Electronic Signature (RES) instruction must be issued. No other instruction must be issued while the device is in Deep Power-down mode.

The Release from Deep Power-down and Read Electronic Signature (RES) instruction also allows the electronic signature of the device to be output on Serial Data output (Q).

The Deep Power-down mode automatically stops at power-down, and the device always powers up in the Standby mode.

The Deep Power-down (DP) instruction is entered by driving Chip Select (\bar{S}) Low, followed by the instruction code on Serial Data input (D). Chip Select (\bar{S}) must be driven Low for the entire duration of the sequence.

The instruction sequence is shown in [Figure 18](#).

Chip Select (\bar{S}) must be driven High after the eighth bit of the instruction code has been latched in, otherwise the Deep Power-down (DP) instruction is not executed. As soon as Chip Select (\bar{S}) is driven High, it requires a delay of t_{DP} before the supply current is reduced to I_{CC2} and the Deep Power-down mode is entered.

Any Deep Power-down (DP) instruction, while an Erase, Program or Write cycle is in progress, is rejected without having any effects on the cycle that is in progress.

Figure 18. Deep Power-down (DP) instruction sequence

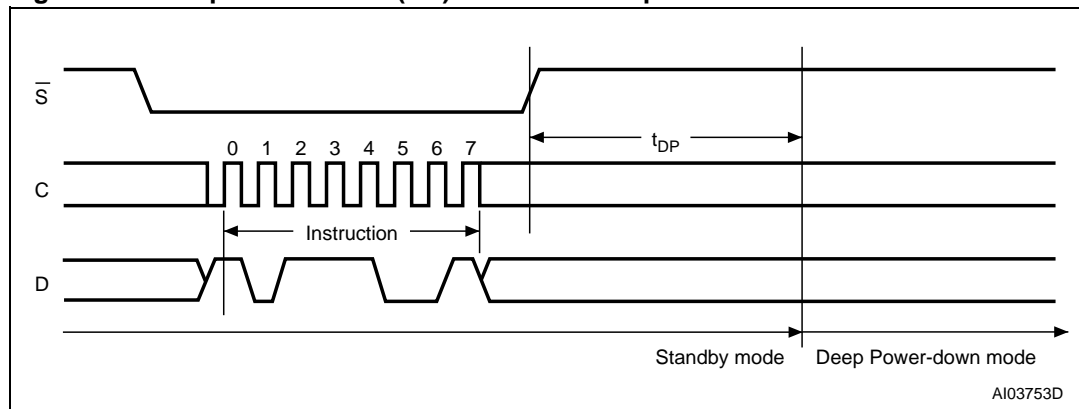

6.12 Release from Deep Power-down and Read Electronic Signature (RES)

To take the device out of Deep Power-down mode, the Release from Deep Power-down and Read Electronic Signature (RES) instruction must be issued. No other instruction must be issued while the device is in Deep Power-down mode.

The instruction can also be used to read, on Serial Data output (Q), the old-style 8-bit electronic signature, whose value for the M25P16 is 14h.

Please note that this is not the same as, or even a subset of, the JEDEC 16-bit electronic signature that is read by the Read Identifier (RDID) instruction. The old-style electronic signature is supported for reasons of backward compatibility, only, and should not be used for new designs. New designs should, instead, make use of the JEDEC 16-bit electronic signature, and the Read Identifier (RDID) instruction.

Except while an Erase, Program or Write Status Register cycle is in progress, the Release from Deep Power-down and Read Electronic Signature (RES) instruction always provides access to the old-style 8-bit electronic signature of the device, and can be applied even if the Deep Power-down mode has not been entered.

Any Release from Deep Power-down and Read Electronic Signature (RES) instruction while an Erase, Program or Write Status Register cycle is in progress, is not decoded, and has no effect on the cycle that is in progress.

The device is first selected by driving Chip Select (\overline{S}) Low. The instruction code is followed by 3 dummy bytes, each bit being latched-in on Serial Data input (D) during the rising edge of Serial Clock (C). Then, the old-style 8-bit electronic signature, stored in the memory, is shifted out on Serial Data output (Q), each bit being shifted out during the falling edge of Serial Clock (C).

The instruction sequence is shown in [Figure 19](#).

The Release from Deep Power-down and Read Electronic Signature (RES) instruction is terminated by driving Chip Select (\overline{S}) High after the electronic signature has been read at least once. Sending additional clock cycles on Serial Clock (C), while Chip Select (\overline{S}) is driven Low, cause the electronic signature to be output repeatedly.

When Chip Select (\overline{S}) is driven High, the device is put in the Standby Power mode. If the device was not previously in the Deep Power-down mode, the transition to the Standby Power mode is immediate. If the device was previously in the Deep Power-down mode, though, the transition to the Standby Power mode is delayed by t_{RES2} , and Chip Select (\overline{S}) must remain High for at least $t_{RES2(max)}$. Once in the Standby Power mode, the device waits to be selected, so that it can receive, decode and execute instructions.

Figure 19. Release from Deep Power-down and Read Electronic Signature (RES) instruction sequence and data-out sequence

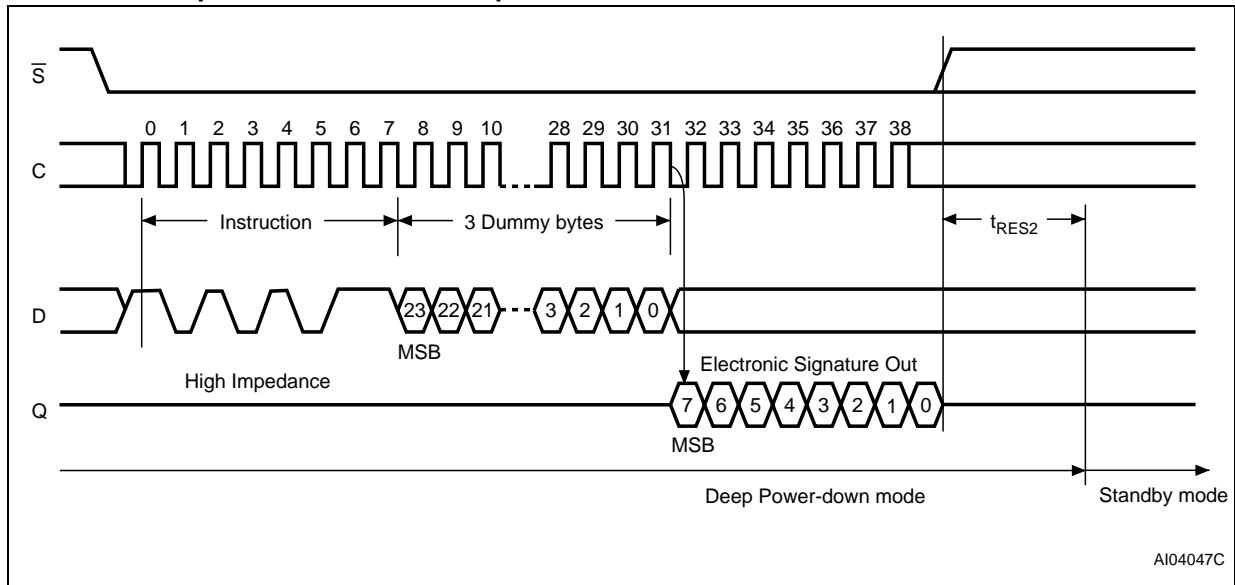

1. The value of the 8-bit electronic signature, for the M25P16, is 14h.

Figure 20. Release from Deep Power-down (RES) instruction sequence

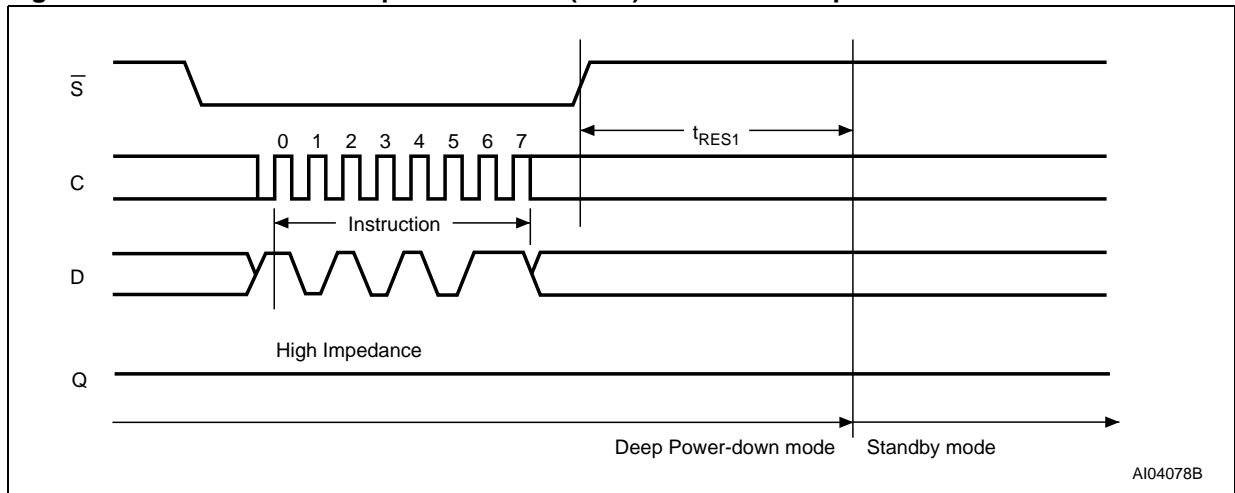

Driving Chip Select (\bar{S}) High after the 8-bit instruction byte has been received by the device, but before the whole of the 8-bit electronic signature has been transmitted for the first time (as shown in [Figure 20](#)), still ensures that the device is put into Standby Power mode. If the device was not previously in the Deep Power-down mode, the transition to the Standby Power mode is immediate. If the device was previously in the Deep Power-down mode, though, the transition to the Standby Power mode is delayed by t_{RES1} , and Chip Select (\bar{S}) must remain High for at least $t_{RES1(max)}$. Once in the Standby Power mode, the device waits to be selected, so that it can receive, decode and execute instructions.

7 Power-up and power-down

At power-up and power-down, the device must not be selected (that is Chip Select (\overline{S}) must follow the voltage applied on V_{CC}) until V_{CC} reaches the correct value:

- $V_{CC}(\text{min})$ at power-up, and then for a further delay of t_{VSL}
- V_{SS} at power-down

A safe configuration is provided in [Section 3: SPI modes](#).

To avoid data corruption and inadvertent write operations during power-up, a Power On Reset (POR) circuit is included. The logic inside the device is held reset while V_{CC} is less than the Power On Reset (POR) threshold voltage, V_{WI} – all operations are disabled, and the device does not respond to any instruction.

Moreover, the device ignores all Write Enable (WREN), Page Program (PP), Sector Erase (SE), Bulk Erase (BE) and Write Status Register (WRSR) instructions until a time delay of t_{PUW} has elapsed after the moment that V_{CC} rises above the V_{WI} threshold. However, the correct operation of the device is not guaranteed if, by this time, V_{CC} is still below $V_{CC}(\text{min})$. No Write Status Register, Program or Erase instructions should be sent until the later of:

- t_{PUW} after V_{CC} passed the V_{WI} threshold
- t_{VSL} after V_{CC} passed the $V_{CC}(\text{min})$ level.

These values are specified in [Table 8](#).

If the delay, t_{VSL} , has elapsed, after V_{CC} has risen above $V_{CC}(\text{min})$, the device can be selected for READ instructions even if the t_{PUW} delay is not yet fully elapsed.

At power-up, the device is in the following state:

- The device is in the Standby mode (not the Deep Power-down mode)
- The Write Enable Latch (WEL) bit is reset
- The Write In Progress (WIP) bit is reset.

Normal precautions must be taken for supply rail decoupling, to stabilize the V_{CC} supply. Each device in a system should have the V_{CC} rail decoupled by a suitable capacitor close to the package pins (generally, this capacitor is of the order of 100 nF).

At power-down, when V_{CC} drops from the operating voltage, to below the Power On Reset (POR) threshold voltage, V_{WI} , all operations are disabled and the device does not respond to any instruction (the designer needs to be aware that if a power-down occurs while a Write, Program or Erase cycle is in progress, some data corruption can result).

Figure 21. Power-up timing

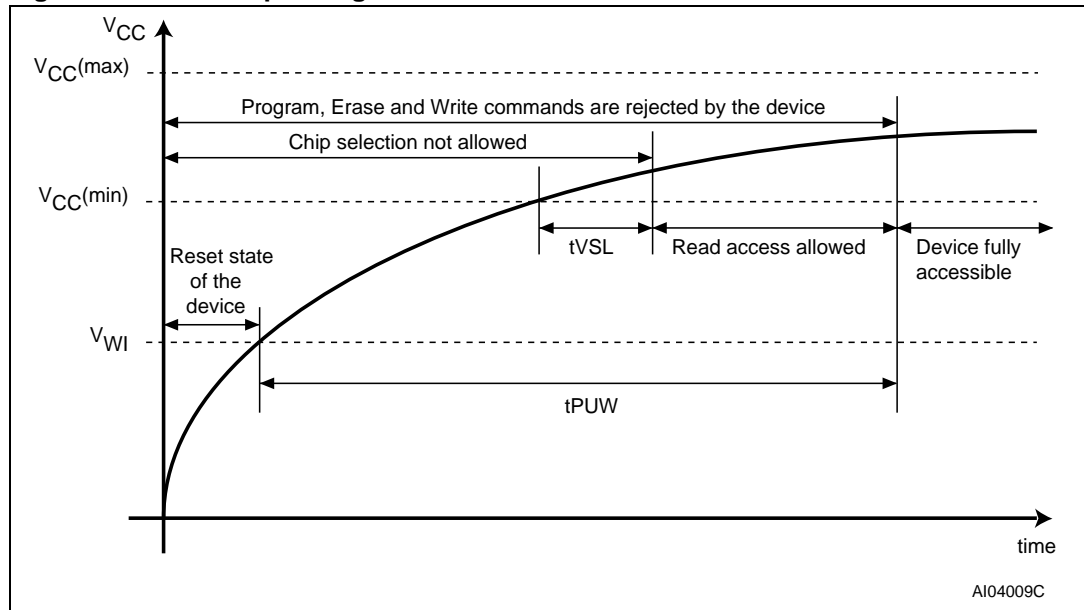

Table 8. Power-up timing and V_{WI} threshold

Symbol	Parameter	Min	Max	Unit
$t_{VSL}^{(1)}$	$V_{CC(min)}$ to \bar{S} Low	30		μs
$t_{PUW}^{(1)}$	Time delay to Write instruction	1	10	ms
$V_{WI}^{(1)}$	Write Inhibit voltage	1.5	2.5	V

1. These parameters are characterized only.

8 Initial delivery state

The device is delivered with the memory array erased: all bits are set to '1' (each byte contains FFh). The Status Register contains 00h (all Status Register bits are 0).

9 Maximum rating

Stressing the device above the rating listed in [Table 9: Absolute maximum ratings](#) may cause permanent damage to the device. These are stress ratings only and operation of the device at these or any other conditions above those indicated in the operating sections of this specification is not implied. Exposure to absolute maximum rating conditions for extended periods may affect device reliability. Refer also to the STMicroelectronics SURE Program and other relevant quality documents.

Table 9. Absolute maximum ratings

Symbol	Parameter	Min	Max	Unit
T_{STG}	Storage temperature	-65	150	°C
T_{LEAD}	Lead temperature during soldering		see ⁽¹⁾	°C
V_{IO}	Input and output voltage (with respect to ground)	-0.6 ⁽²⁾	$V_{CC} + 0.6$ ⁽³⁾	V
V_{CC}	Supply voltage	-0.6	4.0	V
V_{ESD}	Electrostatic discharge voltage (Human Body model) ⁽⁴⁾	-2000	2000	V

1. Compliant with JEDEC Std J-STD-020C (for small body, Sn-Pb or Pb assembly), the ST ECOPACK® 7191395 specification, and the European directive on Restrictions on Hazardous Substances (RoHS) 2002/95/EU.
2. The minimum voltage may reach the value of -2 V for no more than 20 ns during transitions.
3. The maximum voltage may reach the value of $V_{CC}+2$ V for no more than 20 ns during transitions.
4. JEDEC Std JESD22-A114A (C1 = 100 pF, R1 = 1500 Ω, R2 = 500 Ω).

10 DC and AC parameters

This section summarizes the operating and measurement conditions, and the DC and AC characteristics of the device. The parameters in the DC and AC characteristic tables that follow are derived from tests performed under the measurement conditions summarized in the relevant tables. Designers should check that the operating conditions in their circuit match the measurement conditions when relying on the quoted parameters.

Table 10. Operating conditions

Symbol	Parameter	Min	Max	Unit	
V_{CC}	Supply voltage	2.7	3.6	V	
T_A	Ambient operating temperature	grade 3	-40	125	°C
		grade 6	-40	85	°C

Table 11. Data retention and endurance

Parameter	Condition	Min	Max	Unit
Erase/Program cycles	Device grade 6		100 000	Cycles per sector
	Device grade 3		10 000	
Data retention	at 55 °C		20	years

Table 12. AC measurement conditions

Symbol	Parameter	Min	Max	Unit
C_L	Load capacitance	30		pF
	Input rise and fall times		5	ns
	Input pulse voltages	0.2 V_{CC} to 0.8 V_{CC}		V
	Input timing reference voltages	0.3 V_{CC} to 0.7 V_{CC}		V
	Output timing reference voltages	$V_{CC} / 2$		V

Figure 22. AC measurement I/O waveform

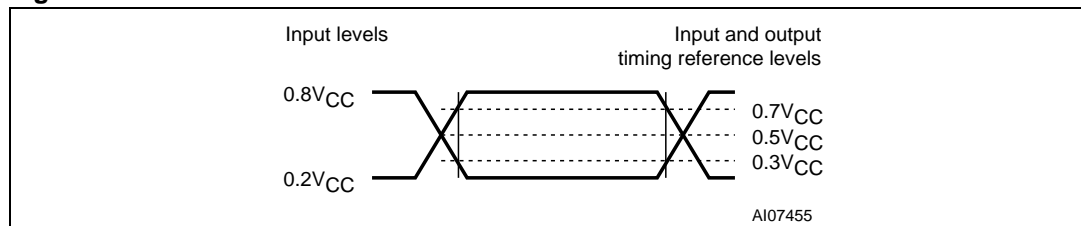

Table 13. Capacitance⁽¹⁾

Symbol	Parameter	Test Condition	Min	Max	Unit
C_{OUT}	Output capacitance (Q)	$V_{OUT} = 0 V$		8	pF
C_{IN}	Input capacitance (other pins)	$V_{IN} = 0 V$		6	pF

1. Sampled only, not 100% tested, at $T_A = 25 °C$ and a frequency of 20 MHz.

Table 14. DC characteristics

Symbol	Parameter	Test condition (in addition to those in Table 10)	Min	Max	Unit
I_{LI}	Input leakage current			± 2	μA
I_{LO}	Output leakage current			± 2	μA
I_{CC1}	Standby current	Grade 6	$\bar{S} = V_{CC}, V_{IN} = V_{SS} \text{ or } V_{CC}$	50	μA
		Grade 3		100	μA
I_{CC2}	Deep Power-down current	Grade 6	$\bar{S} = V_{CC}, V_{IN} = V_{SS} \text{ or } V_{CC}$	10	μA
		Grade 3		100	μA
I_{CC3}	Operating current (READ)	$C = 0.1V_{CC} / 0.9.V_{CC}$ at 75 MHz, Q = open		12	mA
		$C = 0.1V_{CC} / 0.9.V_{CC}$ at 33 MHz, Q = open		4	mA
I_{CC4}	Operating current (PP)	$\bar{S} = V_{CC}$		15	mA
I_{CC5}	Operating current (WRSR)	$\bar{S} = V_{CC}$		15	mA
I_{CC6}	Operating current (SE)	$\bar{S} = V_{CC}$		15	mA
I_{CC7}	Operating current (BE)	$\bar{S} = V_{CC}$		15	mA
V_{IL}	Input low voltage		-0.5	$0.3V_{CC}$	V
V_{IH}	Input high voltage		$0.7V_{CC}$	$V_{CC}+0.4$	V
V_{OL}	Output low voltage	$I_{OL} = 1.6 \text{ mA}$		0.4	V
V_{OH}	Output high voltage	$I_{OH} = -100 \mu\text{A}$		$V_{CC}-0.2$	V

Table 15. AC characteristics (grade 6, T9HX technology)

Applies only to products made with T9HX technology, identified with process digit '4' ⁽¹⁾ Test conditions specified in Table 10 and Table 12						
Symbol	Alt.	Parameter	Min	Typ ⁽²⁾	Max	Unit
f_C	f_C	Clock frequency for the following instructions: FAST_READ, PP, SE, BE, DP, RES, WREN, WRDI, RDID, RDSR, WRSR	D.C.		75	MHz
f_R		Clock frequency for READ instructions	D.C.		33	MHz
$t_{CH}^{(3)}$	t_{CLH}	Clock High time	6			ns
$t_{CL}^{(2)}$	t_{CLL}	Clock Low time	6			ns
$t_{CLCH}^{(4)}$		Clock Rise time ⁽⁵⁾ (peak to peak)	0.1			V/ns
$t_{CHCL}^{(4)}$		Clock Fall time ⁽⁵⁾ (peak to peak)	0.1			V/ns
t_{SLCH}	t_{CSS}	\overline{S} Active Setup time (relative to C)	5			ns
t_{CHSL}		\overline{S} Not Active Hold time (relative to C)	5			ns
t_{DVCH}	t_{DSU}	Data In Setup time	2			ns
t_{CHDX}	t_{DH}	Data In Hold time	5			ns
t_{CHSH}		\overline{S} Active Hold time (relative to C)	5			ns
t_{SHCH}		\overline{S} Not Active Setup time (relative to C)	5			ns
t_{SHSL}	t_{CSH}	\overline{S} Deselect time	100			ns
$t_{SHQZ}^{(4)}$	t_{DIS}	Output Disable time			8	ns
t_{CLQV}	t_V	Clock Low to Output Valid under 30 pF/10 pF			8/6	ns
t_{CLQX}	t_{HO}	Output Hold time	0			ns
t_{HLCH}		\overline{HOLD} Setup time (relative to C)	5			ns
t_{CHHH}		\overline{HOLD} Hold time (relative to C)	5			ns
t_{HHCH}		\overline{HOLD} Setup time (relative to C)	5			ns
t_{CHHL}		\overline{HOLD} Hold time (relative to C)	5			ns
$t_{HHQX}^{(4)}$	t_{LZ}	\overline{HOLD} to Output Low-Z			8	ns
$t_{HLQZ}^{(4)}$	t_{HZ}	\overline{HOLD} to Output High-Z			8	ns
$t_{WHSL}^{(6)}$		Write Protect Setup time	20			ns
$t_{SHWL}^{(6)}$		Write Protect Hold time	100			ns
$t_{DP}^{(4)}$		\overline{S} High to Deep Power-down mode			3	μ s
$t_{RES1}^{(4)}$		\overline{S} High to Standby mode without Read Electronic Signature			30	μ s
$t_{RES2}^{(4)}$		\overline{S} High to Standby mode with Read Electronic Signature			30	μ s
t_W		Write Status Register cycle time		1.3	15	ms

Table 15. AC characteristics (grade 6, T9HX technology) (continued)

Applies only to products made with T9HX technology, identified with process digit '4' ⁽¹⁾ Test conditions specified in Table 10 and Table 12						
Symbol	Alt.	Parameter	Min	Typ ⁽²⁾	Max	Unit
t _{PP} ⁽⁷⁾		Page Program cycle time (256 bytes)		0.64	5	ms
		Page Program cycle time (n bytes, where n = 1 to 4)		0.01		
		Page Program cycle time (n bytes, where n = 5 to 256)		int(n/8) × 0.02 ⁽⁸⁾		
t _{SE}		Sector Erase cycle time		0.6	3	s
t _{BE}		Bulk Erase cycle time		13	40	s

1. Details of how to find the technology process in the marking are given in AN1995, see also [Section 12: Part numbering](#).
2. Typical values given for T_A = 25 °C.
3. t_{CH} + t_{CL} must be greater than or equal to 1/f_C.
4. Value guaranteed by characterization, not 100% tested in production.
5. Expressed as a slew-rate.
6. Only applicable as a constraint for a WRSR instruction when SRWD is set at '1'.
7. When using the Page Program (PP) instruction to program consecutive bytes, optimized timings are obtained with one sequence including all the bytes versus several sequences of only a few bytes (1 ≤ n ≤ 256).
8. int(A) corresponds to the upper integer part of A. For instance, int(12/8) = 2, int(32/8) = 4, int(15.3) = 16.

Table 16. AC characteristics (25 MHz operation, grade 3)⁽¹⁾

Test conditions specified in Table 10 and Table 12						
Symbol	Alt.	Parameter	Min	Typ	Max	Unit
f _C	f _C	Clock frequency for the following instructions: FAST_READ, PP, SE, BE, DP, RES, WREN, WRDI, RDSR, WRSR	D.C.		25	MHz
f _R		Clock frequency for READ instructions	D.C.		20	MHz
t _{CH} ⁽²⁾	t _{CLH}	Clock High time	18			ns
t _{CL} ⁽²⁾	t _{CLL}	Clock Low time	18			ns
t _{CLCH} ⁽³⁾		Clock Rise time ⁽⁴⁾ (peak to peak)	0.1			V/ns
t _{CHCL} ⁽³⁾		Clock Fall time ⁽⁴⁾ (peak to peak)	0.1			V/ns
t _{SLCH}	t _{CSS}	\overline{S} Active Setup time (relative to C)	10			ns
t _{CHSL}		\overline{S} Not Active Hold time (relative to C)	10			ns
t _{DVCH}	t _{DSU}	Data In Setup time	5			ns
t _{CHDX}	t _{DH}	Data In Hold time	5			ns
t _{CHSH}		\overline{S} Active Hold time (relative to C)	10			ns
t _{SHCH}		\overline{S} Not Active Setup time (relative to C)	10			ns
t _{SHSL}	t _{CSH}	\overline{S} Deselect time	100			ns
t _{SHQZ} ⁽³⁾	t _{DIS}	Output Disable time			15	ns
t _{CLQV}	t _V	Clock Low to Output Valid			15	ns
t _{CLQX}	t _{HO}	Output Hold time	0			ns
t _{HLCH}		\overline{HOLD} Setup time (relative to C)	10			ns
t _{CHHH}		\overline{HOLD} Hold time (relative to C)	10			ns
t _{HHCH}		\overline{HOLD} Setup time (relative to C)	10			ns
t _{CHHL}		\overline{HOLD} Hold time (relative to C)	10			ns
t _{HHQX} ⁽³⁾	t _{LZ}	\overline{HOLD} to Output Low-Z			15	ns
t _{HLQZ} ⁽³⁾	t _{HZ}	\overline{HOLD} to Output High-Z			20	ns
t _{WHSL} ⁽⁵⁾		Write Protect Setup time	20			ns
t _{SHWL} ⁽⁵⁾		Write Protect Hold time	100			ns
t _{DP} ⁽³⁾		\overline{S} High to Deep Power-down mode			3	μs
t _{RES1} ⁽³⁾		\overline{S} High to Standby mode without Electronic Signature Read			3	μs
t _{RES2} ⁽³⁾		\overline{S} High to Standby mode with Electronic Signature Read			1.8	μs
t _W ⁽⁶⁾		Write Status Register cycle time		1.5	15	ms
t _{PP} ⁽⁶⁾		Page Program cycle time (256 bytes)		0.8	5	ms
		Page Program cycle time (n bytes)		int(n/8) × 0.025 ⁽⁷⁾		

Table 16. AC characteristics (25 MHz operation, grade 3)⁽¹⁾ (continued)

Test conditions specified in Table 10 and Table 12						
Symbol	Alt.	Parameter	Min	Typ	Max	Unit
$t_{SE}^{(6)}$		Sector Erase cycle time		0.8	3	s
$t_{BE}^{(6)}$		Bulk Erase cycle time		17	40	s

1. Preliminary data.
2. $t_{CH} + t_{CL}$ must be greater than or equal to $1/f_C$.
3. Value guaranteed by characterization, not 100% tested in production.
4. Expressed as a slew-rate.
5. Only applicable as a constraint for a WRSR instruction when SRWD is set at '1'.
6. Typical values given for $T_A = 85\text{ }^\circ\text{C}$.
7. $\text{int}(A)$ corresponds to the upper integer part of A. For instance, $\text{int}(12/8) = 2$, $\text{int}(32/8) = 4$ $\text{int}(15.3) = 16$.

Figure 23. Serial input timing

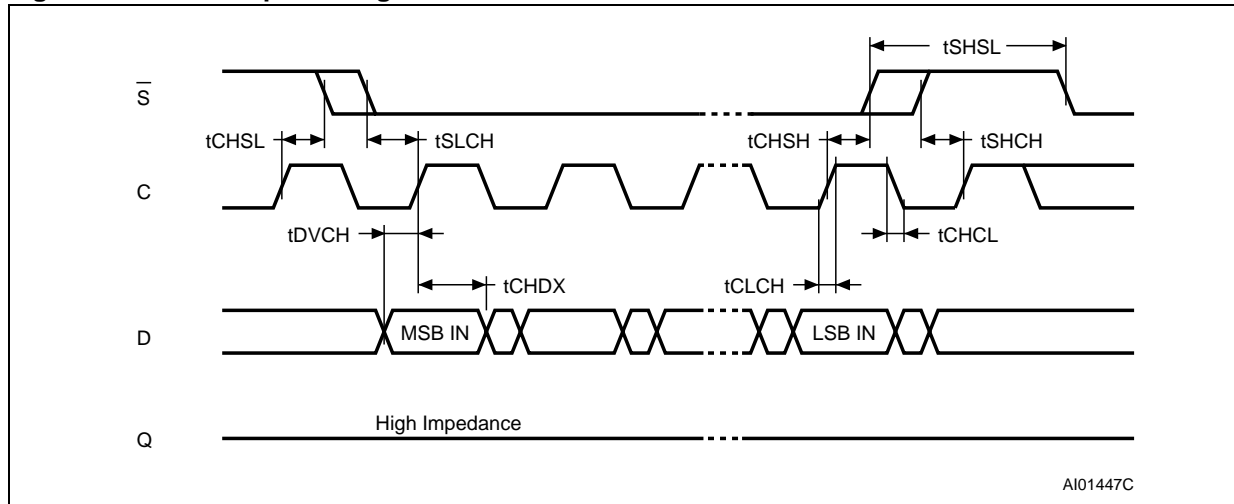

Figure 24. Write Protect setup and hold timing during WRSR when SRWD = 1

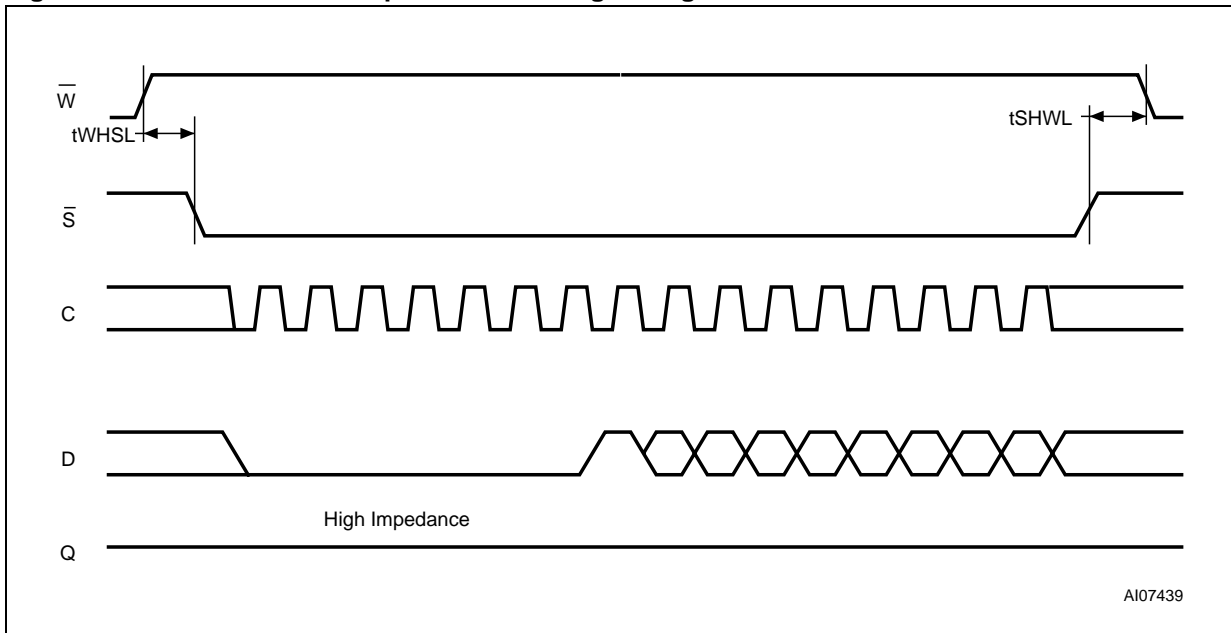

Figure 25. Hold timing

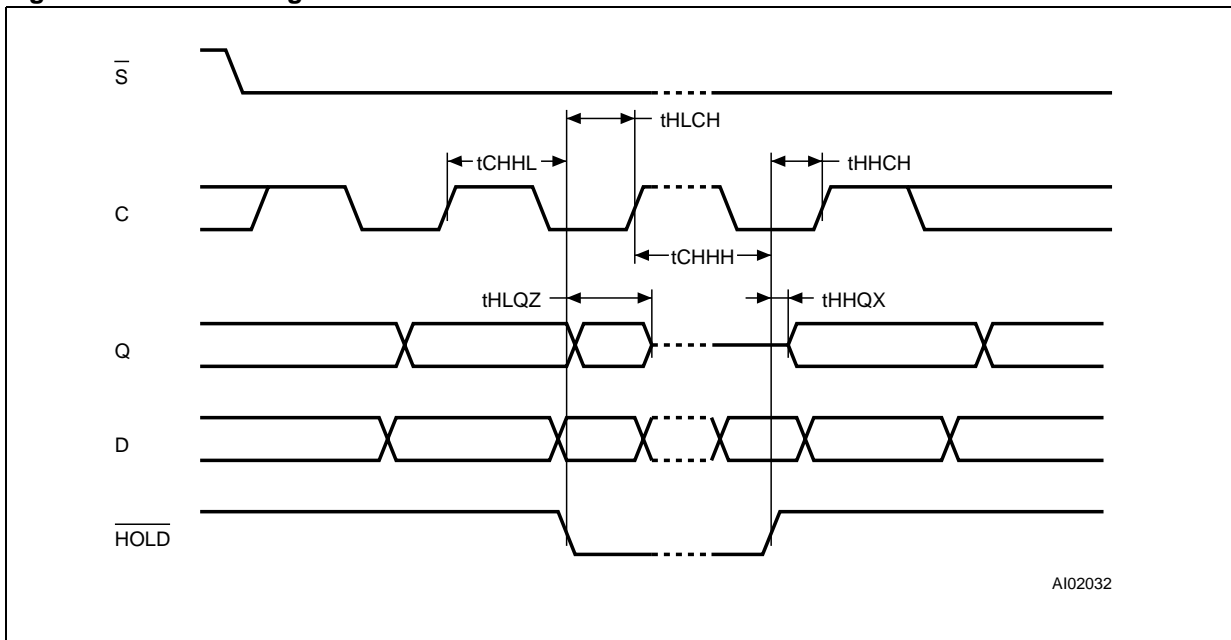
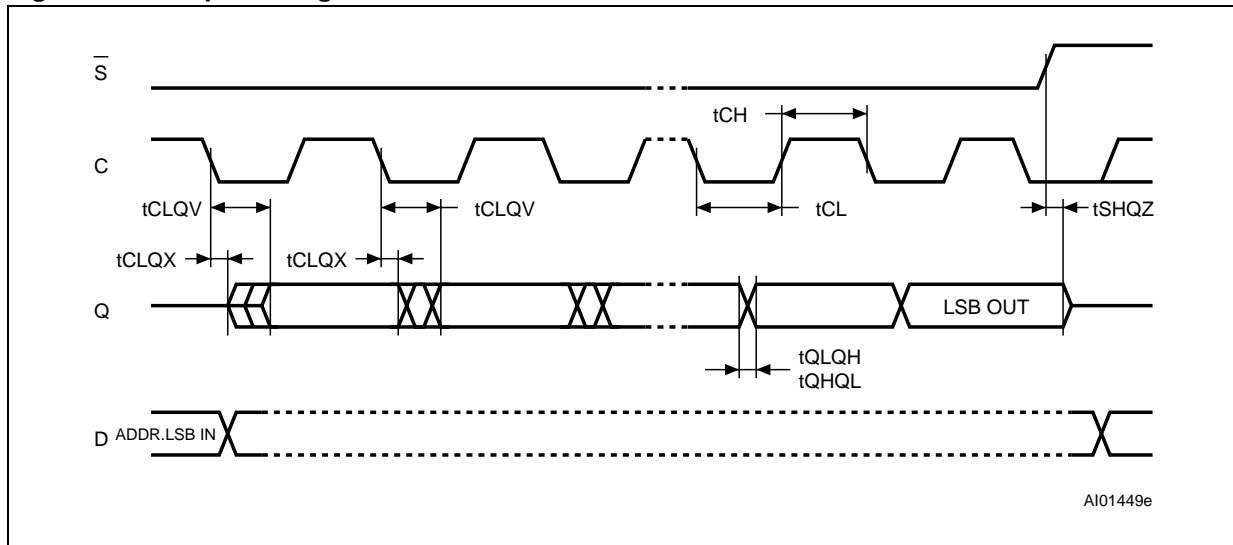

Figure 26. Output timing



11 Package mechanical

In order to meet environmental requirements, ST offers these devices in ECOPACK® packages. These packages have a Lead-free second level interconnect. The category of second level interconnect is marked on the package and on the inner box label, in compliance with JEDEC Standard JESD97. The maximum ratings related to soldering conditions are also marked on the inner box label. ECOPACK is an ST trademark. ECOPACK specifications are available at: www.st.com.

Figure 27. VFQFPN8 (MLP8) 8-lead very thin fine pitch quad flat package no lead, 6 × 5 mm, package outline

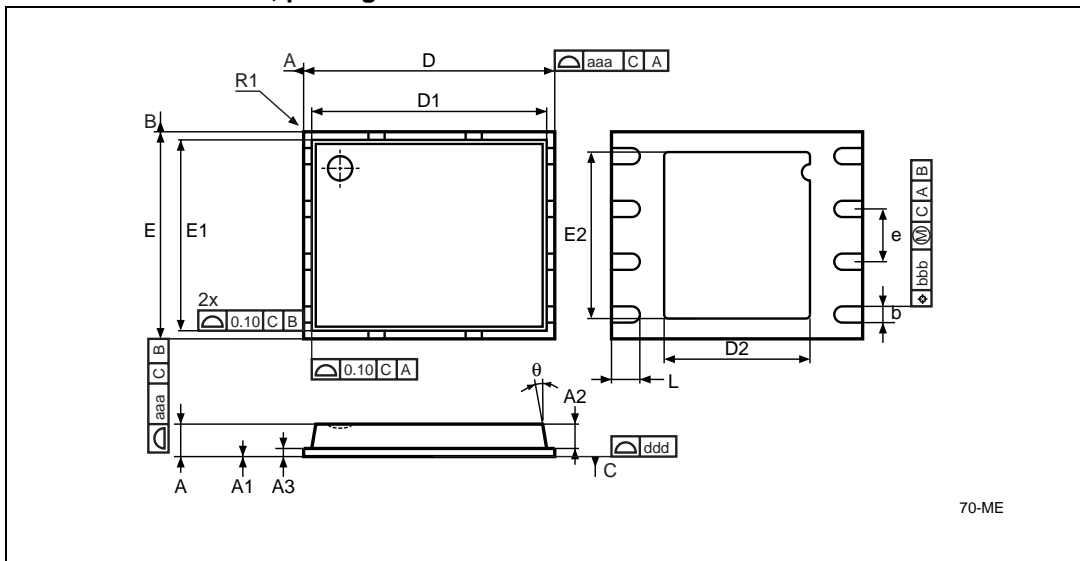

1. Drawing is not to scale.
2. The circle in the top view of the package indicates the position of pin 1.

Table 17. VFQFPN8 (MLP8) 8-lead very thin fine pitch quad flat package no lead, 6 x 5 mm, package mechanical data

Symbol	millimeters			inches		
	Typ	Min	Max	Typ	Min	Max
A	0.85	0.80	1.00	0.033	0.031	0.039
A1		0.00	0.05		0.000	0.002
A2	0.65			0.026		
A3	0.20			0.008		
b	0.40	0.35	0.48	0.016	0.014	0.019
D	6.00			0.236		
D1	5.75			0.226		
D2	3.40	3.20	3.60	0.134	0.126	0.142
E	5.00			0.197		
E1	4.75			0.187		
E2	4.00	3.80	4.30	0.157	0.150	0.169
e	1.27	–	–	0.050	–	–
R1	0.10	0.00		0.004	0.000	
L	0.60	0.50	0.75	0.024	0.020	0.029
∅			12°			12°
aaa			0.15			0.006
bbb			0.10			0.004
ddd			0.05			0.002

Figure 28. VDFPN8 (MLP8) 8-lead very thin dual flat package no lead, 8 × 6 mm, package outline

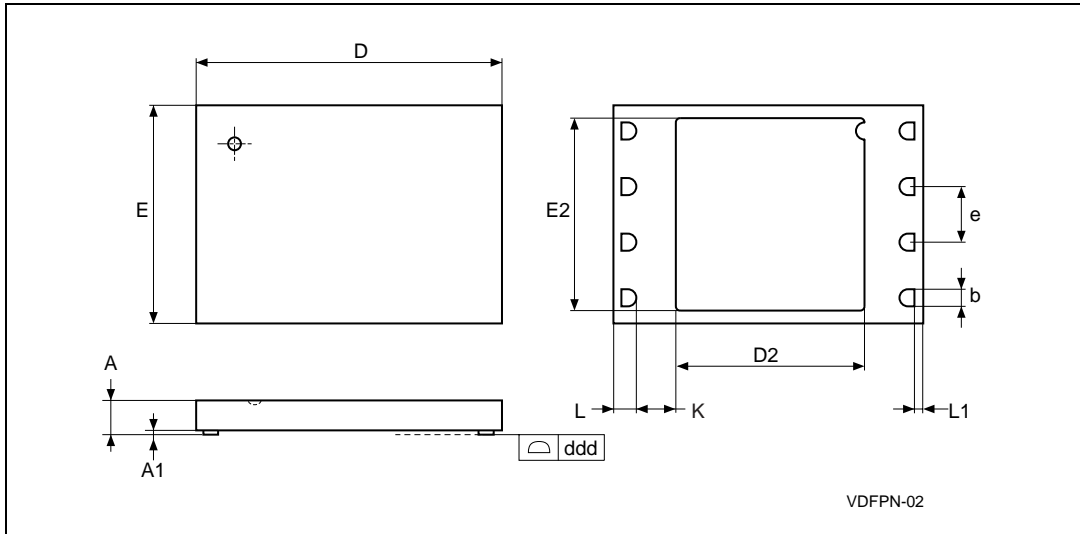

1. Drawing is not to scale.
2. The circle in the top view of the package indicates the position of pin 1.

Table 18. VDFPN8 (MLP8) 8-lead very thin dual flat package no lead, 8 × 6 mm, package mechanical data

Symbol	millimeters			inches		
	Typ	Min	Max	Typ	Min	Max
A	0.85		1.00	0.033		0.039
A1		0.00	0.05		0.000	0.002
b	0.40	0.35	0.48	0.016	0.014	0.019
D	8.00			0.315		
D2	5.16		(1)	0.203		
ddd			0.05			0.002
E	6.00			0.236		
E2	4.80			0.189		
e	1.27	–	–	0.050	–	–
K		0.82			0.032	
L	0.50	0.45	0.60	0.020	0.018	0.024
L1			0.15			0.006
N	8			8		

1. D2 Max should not exceed (D – K – 2 × L).

Figure 29. SO8N – 8 lead plastic small outline, 150 mils body width, package outline

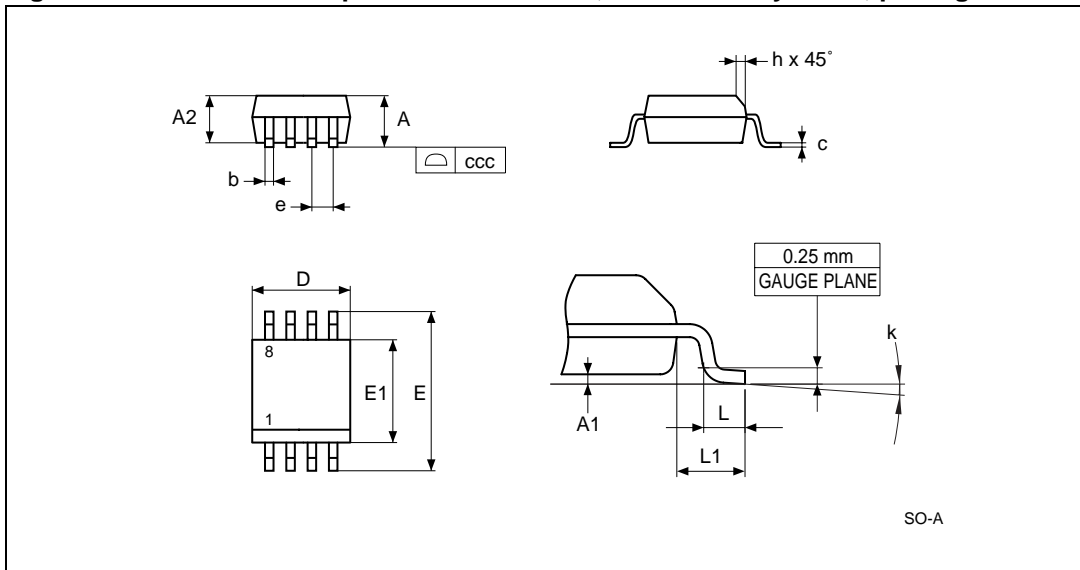

1. Drawing is not to scale.

Table 19. SO8N – 8 lead plastic small outline, 150 mils body width, package mechanical data

Symbol	millimeters			inches		
	Typ	Min	Max	Typ	Min	Max
A			1.75			0.069
A1		0.10	0.25		0.004	0.010
A2		1.25			0.049	
b		0.28	0.48		0.011	0.019
c		0.17	0.23		0.007	0.009
ccc			0.10			0.004
D	4.90	4.80	5.00	0.193	0.189	0.197
E	6.00	5.80	6.20	0.236	0.228	0.244
E1	3.90	3.80	4.00	0.154	0.150	0.157
e	1.27	–	–	0.050	–	–
h		0.25	0.50		0.010	0.020
k		0°	8°		0°	8°
L		0.40	1.27		0.016	0.050
L1	1.04			0.041		

Figure 30. SO8W – 8 lead plastic small outline, 208 mils body width, package outline

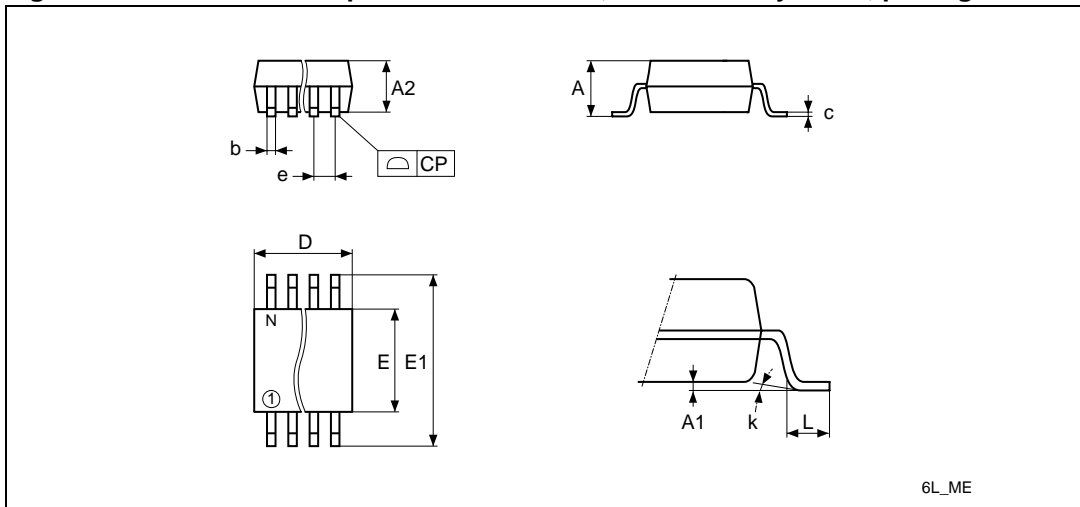

1. Drawing is not to scale.

Table 20. SO8 wide – 8 lead plastic small outline, 208 mils body width, package mechanical data

Symbol	millimeters			inches		
	Typ	Min	Max	Typ	Min	Max
A			2.50			0.098
A1		0.00	0.25		0.000	0.010
A2		1.51	2.00		0.059	0.079
b	0.40	0.35	0.51	0.016	0.014	0.020
c	0.20	0.10	0.35	0.008	0.004	0.014
CP			0.10			0.004
D			6.05			0.238
E		5.02	6.22		0.198	0.245
E1		7.62	8.89		0.300	0.350
e	1.27	–	–	0.050	–	–
k		0°	10°		0°	10°
L		0.50	0.80		0.020	0.031
N	8			8		

Figure 31. SO16 wide – 16-lead plastic small outline, 300 mils body width, package outline

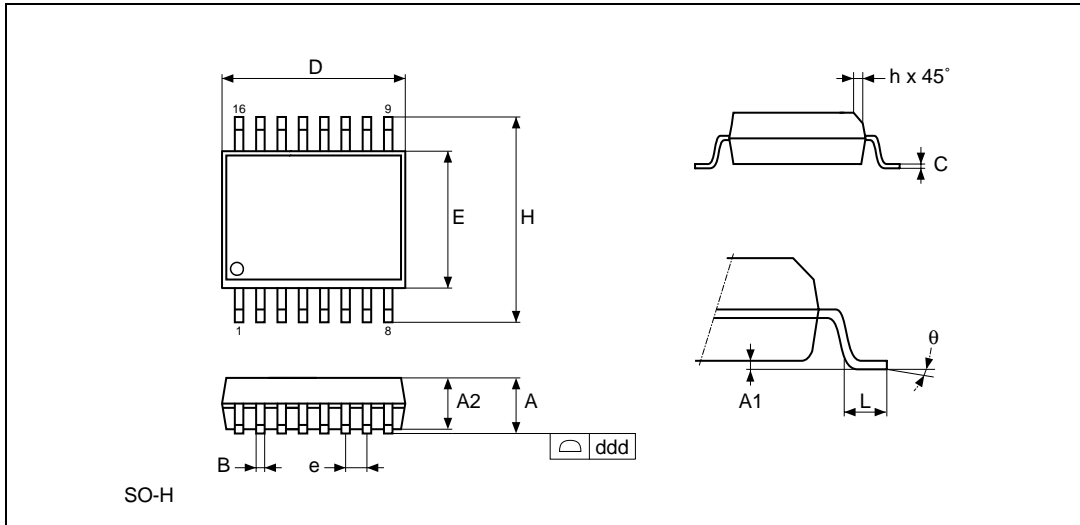

1. Drawing is not to scale.

Table 21. SO16 wide – 16-lead plastic small outline, 300 mils body width, mechanical data

Symbol	millimeters			inches		
	Typ	Min	Max	Typ	Min	Max
A		2.35	2.65		0.093	0.104
A1		0.10	0.30		0.004	0.012
B		0.33	0.51		0.013	0.020
C		0.23	0.32		0.009	0.013
D		10.10	10.50		0.398	0.413
E		7.40	7.60		0.291	0.299
e	1.27	–	–	0.050	–	–
H		10.00	10.65		0.394	0.419
h		0.25	0.75		0.010	0.030
L		0.40	1.27		0.016	0.050
θ		0°	8°		0°	8°
ddd			0.10			0.004

12 Part numbering

Table 22. Ordering information scheme

Example:	M25P16	-	V	ME	6	T	P
Device type							
M25P = Serial Flash memory for code storage							
Device function							
16 = 16 Mbit (2 Mbit x 8)							
Operating voltage							
V = V _{CC} = 2.7 V to 3.6 V							
Package							
MP = VFQFPN8 6 x 5 mm (MLP8)							
ME = VDFPN8 8 x 6 mm (MLP8) ⁽¹⁾							
MN = SO8N (150 mils width)							
MW = SO8W (208 mils width)							
MF = SO16 (300 mils width)							
Device grade							
6 = Industrial temperature range, -40 to 85 °C.							
Device tested with standard test flow							
3 ⁽²⁾ = Automotive temperature range, -40 to 125 °C.							
Device tested with high reliability certified flow.							
Option							
blank = Standard packing							
T = Tape and reel packing							
Plating Technology							
P or G = ECOPACK® (RoHS compliant)							

1. Not for new design, please use VFQFPN8 6 x 5 mm.
2. Grade 3 is available only in devices delivered in SO8N packages.

Note: For a list of available options (speed, package, etc.), for further information on any aspect of this device or when ordering parts operating at 75 MHz (0.11 μm, process digit '4'), please contact your nearest ST Sales Office.

13 Revision history

Table 23. Document revision history

Date	Revision	Changes
16-Jan-2002	0.1	Target Specification Document written
23-Apr-2002	0.4	Clarification of descriptions of entering Standby Power mode from Deep Power-down mode, and of terminating an instruction sequence or data-out sequence. ICC2(max) value changed to 10 μ A
13-Dec-2002	0.5	Typical Page Program time improved. Write Protect setup and hold times specified, for applications that switch Write Protect to exit the Hardware Protection mode immediately before a WRSR, and to enter the Hardware Protection mode again immediately after
15-May-2003	0.6	MLP8 package added
	0.7	50MHz operation, and RDID instruction added. Published internally, only
20-Jun-2003	0.8	8x6 MLP8 and SO16(300 mil) packages added
24-Sep-2003	1.0	t _{PP} , t _{SE} and t _{BE} revised. SO16 package code changed. Output Timing Reference Voltage changed. Document promoted to Preliminary Data.
24-Nov-2003	2.0	Table of contents, warning about exposed paddle on MLP8, and Pb-free options added. Value of t _{VSL} (min) and t _{BE} (typ) changed. Change of naming for VDFPN8 packages. Document promoted to full Datasheet.
17-May-2004	3.0	MLP8(5x6) package removed. Soldering temperature information clarified for RoHS compliant devices. Device Grade clarified
01-Apr-2005	4.0	Notes 1 and 2 removed from Table 22: Ordering information scheme . Small text changes. Read Identification (RDID) , Deep Power-down (DP) and Release from Deep Power-down and Read Electronic Signature (RES) instructions, and Active Power, Standby Power and Deep Power-down modes paragraph clarified.
01-Aug-2005	5.0	Updated Page Program (PP) instructions in Page programming, Page Program (PP) and Table 15: AC characteristics (Grade 6).
20-Oct-2005	6.0	VFQFPN8 package added (see Figure 27: VFQFPN8 (MLP8) 8-lead very thin fine pitch quad flat package no lead, 6 x 5 mm, package outline and Table 17: VFQFPN8 (MLP8) 8-lead very thin fine pitch quad flat package no lead, 6 x 5 mm, package mechanical data). All packages are ECOPACK®. "Blank" option removed under Plating Technology .
27-Feb-2006	7	SO8 Narrow and SO8 Wide packages added (see Section 11: Package mechanical). VDFPN8 package updated (see Table 18: VDFPN8 (MLP8) 8-lead very thin dual flat package no lead, 8 x 6 mm, package mechanical data). Note 1 added to Table 22: Ordering information scheme .
04-Jul-2006	8	Figure 4: Bus master and memory devices on the SPI bus updated and Note 2 added. SO8N package specifications updated (see Figure 29 and Table 19). Small text changes.

Table 23. Document revision history (continued)

Date	Revision	Changes
10-Oct-2006	9	Page Program, Sector Erase and Bulk Erase updated in Features . V_{IO} max modified in Table 9: Absolute maximum ratings . Table 15: AC characteristics (grade 6, T9HX technology) added. VFQFPN8 package specifications updated (see Table 17). Note 1 added to Table 18 . Note: on page 52 modified.
09-Jan-2007	10	Small text changes. Hardware Write protection added to Features . VCC supply voltage and VSS ground signal descriptions added. Figure 4: Bus master and memory devices on the SPI bus modified, note 2 removed and replaced by an explanatory paragraph. Write In Progress bit behavior specified at Power-up (see Section 7: Power-up and power-down). T_{LEAD} added to Table 9: Absolute maximum ratings . Grade 3 temperature range added. Table 11: Data retention and endurance and Table 16: AC characteristics (25 MHz operation, grade 3) added. SO8W and VFQFPN8 package specifications updated (see Section 11: Package mechanical).
15-Jun-2007	11	Eliminated the reference to the Deep Power-down mode and updated the Read Identification instruction in Section 6.3: Read Identification (RDID) . Inserted UID and CFI content columns in Table 5: Read Identification (RDID) data-out sequence . Modified Data bytes for RDID instruction in Table 4: Instruction set . Modified Q signal in Figure 10: Read Identification (RDID) instruction sequence and data-out sequence . Modified Test condition and maximum values for I_{CC3} in Table 14: DC characteristics . Eliminated Table 15: AC characteristics (Grade 6) . Modified the maximum value for f_C in Table 15: AC characteristics (grade 6, T9HX technology) .
31-Oct-2007	12	Removed 'low voltage' from the title. Changed the typical time for Bulk Erase on page 1. Section 6.3: Read Identification (RDID) updated. Added note 2 and 3 to Table 9: Absolute maximum ratings . Modified maximum value for t_{CLQV} in Table 15: AC characteristics (grade 6, T9HX technology) .

Please Read Carefully:

Information in this document is provided solely in connection with ST products. STMicroelectronics NV and its subsidiaries ("ST") reserve the right to make changes, corrections, modifications or improvements, to this document, and the products and services described herein at any time, without notice.

All ST products are sold pursuant to ST's terms and conditions of sale.

Purchasers are solely responsible for the choice, selection and use of the ST products and services described herein, and ST assumes no liability whatsoever relating to the choice, selection or use of the ST products and services described herein.

No license, express or implied, by estoppel or otherwise, to any intellectual property rights is granted under this document. If any part of this document refers to any third party products or services it shall not be deemed a license grant by ST for the use of such third party products or services, or any intellectual property contained therein or considered as a warranty covering the use in any manner whatsoever of such third party products or services or any intellectual property contained therein.

UNLESS OTHERWISE SET FORTH IN ST'S TERMS AND CONDITIONS OF SALE ST DISCLAIMS ANY EXPRESS OR IMPLIED WARRANTY WITH RESPECT TO THE USE AND/OR SALE OF ST PRODUCTS INCLUDING WITHOUT LIMITATION IMPLIED WARRANTIES OF MERCHANTABILITY, FITNESS FOR A PARTICULAR PURPOSE (AND THEIR EQUIVALENTS UNDER THE LAWS OF ANY JURISDICTION), OR INFRINGEMENT OF ANY PATENT, COPYRIGHT OR OTHER INTELLECTUAL PROPERTY RIGHT.

UNLESS EXPRESSLY APPROVED IN WRITING BY AN AUTHORIZED ST REPRESENTATIVE, ST PRODUCTS ARE NOT RECOMMENDED, AUTHORIZED OR WARRANTED FOR USE IN MILITARY, AIR CRAFT, SPACE, LIFE SAVING, OR LIFE SUSTAINING APPLICATIONS, NOR IN PRODUCTS OR SYSTEMS WHERE FAILURE OR MALFUNCTION MAY RESULT IN PERSONAL INJURY, DEATH, OR SEVERE PROPERTY OR ENVIRONMENTAL DAMAGE. ST PRODUCTS WHICH ARE NOT SPECIFIED AS "AUTOMOTIVE GRADE" MAY ONLY BE USED IN AUTOMOTIVE APPLICATIONS AT USER'S OWN RISK.

Resale of ST products with provisions different from the statements and/or technical features set forth in this document shall immediately void any warranty granted by ST for the ST product or service described herein and shall not create or extend in any manner whatsoever, any liability of ST.

ST and the ST logo are trademarks or registered trademarks of ST in various countries.

Information in this document supersedes and replaces all information previously supplied.

The ST logo is a registered trademark of STMicroelectronics. All other names are the property of their respective owners.

© 2007 STMicroelectronics - All rights reserved

STMicroelectronics group of companies

Australia - Belgium - Brazil - Canada - China - Czech Republic - Finland - France - Germany - Hong Kong - India - Israel - Italy - Japan - Malaysia - Malta - Morocco - Singapore - Spain - Sweden - Switzerland - United Kingdom - United States of America

www.st.com

