



# UPSD3212A UPSD3212C, UPSD3212CV

Flash programmable system devices  
with 8032 MCU and USB and programmable logic

## Features

- Fast 8-bit 8032 MCU
  - 40 MHz at 5.0 V, 24 MHz at 3.3 V
  - Core, 12-clocks per instruction
- Dual Flash memories with memory management
  - Place either memory into 8032 program address space or data address space
  - Read-while-write operation for in-application programming and EEPROM emulation
  - Single voltage program and erase
  - 100 K minimum erase cycles, 15-year retention
- Clock, reset, and supply management
  - Normal, idle, and power down modes
  - Power-on and low voltage reset supervisor
  - Programmable watchdog timer
- Programmable logic, general-purpose
  - 16 macrocells
  - Implements state machines, glue-logic, etc.
- Timers and interrupts
  - Three 8032 standard 16-bit timers
  - 10 Interrupt sources with two external interrupt pins
- A/D converter
  - Four channels, 8-bit resolution, 10  $\mu$ s

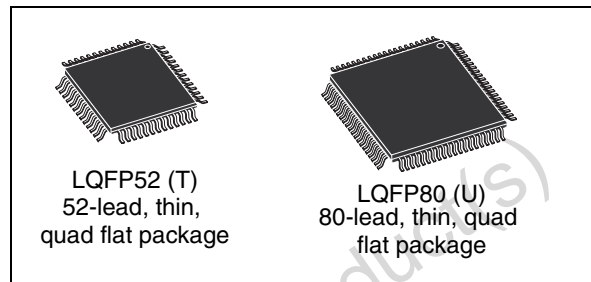

- Communication interfaces
  - USB v1.1, low-speed 1.5 Mbps, 3 endpoints
  - I<sup>2</sup>C master/slave bus controller
  - Two UARTs with independent baud rate
  - Six I/O ports with up to 46 I/O pins
  - 8032 address/data bus available on TQFP80 package
  - 5 PWM outputs, 8-bit resolution
- JTAG in-system programming
  - Program the entire device in as little as 10 seconds
- Single supply voltage
  - 4.5 to 5.5 V
  - 3.0 to 3.6 V
- ECOPACK® packages

Table 1. Device summary

Order code	Max. clock (MHz)	1st Flash	2nd Flash	SRAM	GPIO	USB	8032 bus	V <sub>CC</sub> (V)	Pkg.	Temp.
UPSD3212C-40T6	40	64 KB	16 KB	2 KB	37	No	No	4.5-5.5	TQFP52	–40°C to 85°C
UPSD3212CV-24T6	24	64 KB	16 KB	2 KB	37	No	No	3.0-3.6	TQFP52	–40°C to 85°C
UPSD3212C-40U6	40	64 KB	16 KB	2 KB	46	No	Yes	4.5-5.5	TQFP80	–40°C to 85°C
UPSD3212CV-24U6	24	64 KB	16 KB	2 KB	46	No	Yes	3.0-3.6	TQFP80	–40°C to 85°C
UPSD3212A-40T6	40	64 KB	16 KB	2 KB	37	Yes	No	4.5-5.5	TQFP52	–40°C to 85°C
UPSD3212A-40U6	40	64 KB	16 KB	2 KB	46	Yes	Yes	4.5-5.5	TQFP80	–40°C to 85°C

# Contents

<b>1</b>	<b>UPSD321xx description</b>	<b>9</b>
1.1	52-pin package I/O port	15
<b>2</b>	<b>Architecture overview</b>	<b>16</b>
2.1	Memory organization	16
2.2	Registers	16
2.2.1	Accumulator	17
2.2.2	B register	17
2.2.3	Stack pointer	17
2.2.4	Program counter	18
2.2.5	Program status word	18
2.2.6	Registers R0~R7	18
2.2.7	Data pointer register	18
2.3	Program memory	19
2.4	Data memory	19
2.5	RAM	19
2.6	XRAM-PSD	20
2.7	SFR	20
2.8	Addressing modes	21
2.8.1	Direct addressing	21
2.8.2	Indirect addressing	21
2.8.3	Register addressing	22
2.8.4	Register-specific addressing	22
2.8.5	Immediate constants addressing	22
2.8.6	Indexed addressing	22
2.9	Arithmetic instructions	23
2.10	Logical instructions	24
2.11	Data transfers	25
2.11.1	Internal RAM	25
2.11.2	External RAM	27
2.11.3	Lookup tables	28
2.12	Boolean instructions	29
2.13	Relative offset	30

2.14	Jump instructions .....	30
2.15	Machine cycles .....	33
<b>3</b>	<b>UPSD321xx hardware description .....</b>	<b>35</b>
<b>4</b>	<b>MCU module description .....</b>	<b>36</b>
4.1	Special function registers .....	36
<b>5</b>	<b>Interrupt system .....</b>	<b>42</b>
5.1	External Int0 interrupt .....	42
5.2	Timer 0 and 1 interrupts .....	42
5.3	Timer 2 interrupt .....	42
5.4	I <sup>2</sup> C interrupt .....	42
5.5	External Int1 interrupt .....	43
5.6	USB interrupt .....	43
5.7	USART interrupt .....	43
5.8	Interrupt priority structure .....	44
5.9	Interrupt enable structure .....	45
5.10	How interrupts are handled .....	47
<b>6</b>	<b>Power-saving mode .....</b>	<b>48</b>
6.1	Idle mode .....	48
6.2	Power-down mode .....	48
6.3	Power control register .....	48
6.4	Idle mode .....	49
6.5	Power-down mode .....	49
<b>7</b>	<b>I/O ports (MCU module) .....</b>	<b>50</b>
7.1	Port type and description .....	51
<b>8</b>	<b>Oscillator .....</b>	<b>53</b>
<b>9</b>	<b>Supervisory .....</b>	<b>54</b>
9.1	External reset .....	54
9.2	Low V <sub>DD</sub> voltage reset .....	54

9.3	Watchdog timer overflow	55
9.4	USB reset	55
<b>10</b>	<b>Watchdog timer</b>	<b>56</b>
<b>11</b>	<b>Timer/counters (Timer 0, Timer 1 and Timer 2)</b>	<b>58</b>
11.1	Timer 0 and Timer 1	58
11.1.1	Mode 0	59
11.1.2	Mode 1	59
11.1.3	Mode 2	60
11.1.4	Mode 3	61
11.2	Timer 2	61
<b>12</b>	<b>Standard serial interface (UART)</b>	<b>65</b>
12.1	Multiprocessor communications	65
12.2	Serial port control register	66
12.2.1	Baud rates	67
12.2.2	Using Timer 1 to generate baud rates	67
12.2.3	Using Timer/counter 2 to generate baud rates	67
12.2.4	More about Mode 0	68
12.2.5	More about Mode 1	69
12.2.6	More about Modes 2 and 3	70
<b>13</b>	<b>Analog-to-digital convertor (ADC)</b>	<b>76</b>
13.1	ADC interrupt	76
<b>14</b>	<b>Pulse width modulation (PWM)</b>	<b>79</b>
14.1	4-channel PWM unit (PWM 0-3)	79
14.2	Programmable period 8-bit PWM	81
14.3	PWM 4-channel operation	82
<b>15</b>	<b>I<sup>2</sup>C interface</b>	<b>83</b>
15.1	Serial status register (SxSTA: S1STA, S2STA)	85
15.2	Data shift register (SxDAT: S1DAT, S2DAT)	85
15.3	Address register (SxADR: S1ADR, S2ADR)	86

<b>16</b>	<b>USB hardware</b> .....	<b>88</b>
16.1	USB related registers .....	88
16.2	Transceiver .....	94
16.2.1	USB physical layer characteristics .....	94
16.2.2	Low speed driver characteristics .....	95
16.3	Receiver characteristics .....	95
16.4	External USB pull-up resistor .....	96
<b>17</b>	<b>PSD module</b> .....	<b>99</b>
17.1	Functional overview .....	99
17.2	In-system programming (ISP) .....	100
<b>18</b>	<b>Development system</b> .....	<b>102</b>
<b>19</b>	<b>PSD module register description and address offset</b> .....	<b>103</b>
<b>20</b>	<b>PSD module detailed operation</b> .....	<b>104</b>
<b>21</b>	<b>Memory blocks</b> .....	<b>105</b>
21.1	Primary Flash memory and secondary Flash memory description ....	105
21.2	Memory block select signals .....	105
21.2.1	Ready/Busy (PC3) .....	105
21.2.2	Memory operation .....	105
21.3	Instructions .....	106
21.4	Power-down instruction and Power-up mode .....	107
21.4.1	Power-up mode .....	107
21.5	Read .....	108
21.5.1	Read memory contents .....	108
21.5.2	Read memory sector protection status .....	108
21.5.3	Reading the Erase/Program status bits .....	108
21.5.4	Data polling flag (DQ7) .....	108
21.5.5	Toggle flag (DQ6) .....	109
21.5.6	Error flag (DQ5) .....	109
21.5.7	Erase time-out flag (DQ3) .....	109
21.6	Programming Flash memory .....	110
21.6.1	Data Polling .....	110

	21.6.2	Data toggle	111
21.7		Erasing Flash memory	112
	21.7.1	Flash Bulk Erase	112
	21.7.2	Flash Sector Erase	113
	21.7.3	Suspend Sector Erase	113
	21.7.4	Resume Sector Erase	113
21.8		Specific features	114
	21.8.1	Flash memory sector protect	114
	21.8.2	Reset Flash	114
21.9		SRAM	115
21.10		Sector Select and SRAM Select	115
	21.10.1	Example	115
	21.10.2	Memory Select configuration in Program and Data spaces	116
	21.10.3	Separate Space mode	116
	21.10.4	Combined Space modes	117
21.11		Page register	117
<b>22</b>		<b>PLDs</b>	<b>119</b>
	22.1	Turbo bit in PSD module	119
	22.2	Decode PLD (DPLD)	120
	22.3	Complex PLD (CPLD)	121
	22.4	Output macrocell (OMC)	122
	22.5	Product term allocator	123
	22.5.1	Loading and Reading the Output Macrocells (OMC)	124
	22.5.2	OMC mask register	124
	22.5.3	Output enable of the OMC	124
	22.6	Input macrocells (IMC)	125
<b>23</b>		<b>I/O ports (PSD module)</b>	<b>126</b>
	23.1	General port architecture	126
	23.2	Port operating modes	127
	23.3	MCU I/O mode	128
	23.4	PLD I/O mode	128
	23.5	Address Out mode	128
	23.6	Peripheral I/O mode	128

23.7	JTAG in-system programming (ISP) .....	128
23.8	Port configuration registers (PCR) .....	130
23.8.1	Control register .....	130
23.8.2	Direction register .....	130
23.8.3	Drive Select register .....	130
23.9	Port data registers .....	131
23.9.1	Data In .....	131
23.9.2	Data Out register .....	131
23.9.3	Output macrocells (OMC) .....	131
23.9.4	OMC mask register .....	132
23.9.5	Input macrocells (IMC) .....	132
23.9.6	Enable out .....	132
23.10	Ports A and B – functionality and structure .....	133
23.11	Port C – functionality and structure .....	133
23.12	Port D – functionality and structure .....	134
23.13	External chip select .....	135
<b>24</b>	<b>Power management .....</b>	<b>137</b>
24.1	PLD power management .....	139
24.2	PSD chip select input (CSI, PD2) .....	140
24.3	Input clock .....	140
24.4	Input control signals .....	140
<b>25</b>	<b>RESET timing and device status at reset .....</b>	<b>142</b>
25.1	Warm RESET .....	142
25.2	I/O pin, register and PLD status at RESET .....	142
<b>26</b>	<b>Programming in-circuit using the JTAG serial interface .....</b>	<b>144</b>
26.1	Standard JTAG Signals .....	144
26.2	JTAG extensions .....	144
26.3	Security and Flash memory protection .....	145
<b>27</b>	<b>Initial delivery state .....</b>	<b>146</b>
<b>28</b>	<b>AC/DC parameters .....</b>	<b>147</b>

<b>29</b>	<b>Maximum ratings</b> .....	<b>150</b>
<b>30</b>	<b>EMC characteristics</b> .....	<b>151</b>
30.1	Functional EMS (electromagnetic susceptibility) .....	151
30.1.1	ESD .....	151
30.1.2	FTB .....	151
30.2	Designing hardened software to avoid noise problems .....	151
30.2.1	Software recommendations .....	151
30.2.2	Prequalification trials .....	151
30.3	Absolute maximum ratings (electrical sensitivity) .....	152
30.3.1	Electro-static discharge (ESD) .....	152
30.3.2	Latch-up .....	152
30.3.3	Dynamic latch-up .....	152
<b>31</b>	<b>DC and AC parameters</b> .....	<b>153</b>
<b>32</b>	<b>Package mechanical information</b> .....	<b>177</b>
<b>33</b>	<b>Part numbering</b> .....	<b>179</b>
<b>34</b>	<b>Revision history</b> .....	<b>180</b>

Obsolete Product(s) - Obsolete Product(s)



# 1 UPSD321xx description

The UPSD321xx Series combines a fast 8051-based microcontroller with a flexible memory structure, programmable logic, and a rich peripheral mix including USB, to form an ideal embedded controller. At its core is an industry-standard 8032 MCU operating up to 40MHz.

A JTAG serial interface is used for In-System Programming (ISP) in as little as 10 seconds, perfect for manufacturing and lab development.

The USB 1.1 low-speed interface has one Control endpoint and two Interrupt endpoints suitable for HID class drivers.

The 8032 core is coupled to Programmable System Device (PSD) architecture to optimize the 8032 memory structure, offering two independent banks of Flash memory that can be placed at virtually any address within 8032 program or data address space, and easily paged beyond 64 Kbytes using on-chip programmable decode logic.

Dual Flash memory banks provide a robust solution for remote product updates in the field through In-Application Programming (IAP). Dual Flash banks also support EEPROM emulation, eliminating the need for external EEPROM chips.

General purpose programmable logic (PLD) is included to build an endless variety of glue-logic, saving external logic devices. The PLD is configured using the software development tool, PSDsoft Express, available from the web at [www.st.com/psm](http://www.st.com/psm), at no charge.

The UPSD321xx also includes supervisor functions such as a programmable watchdog timer and low-voltage reset.

In order to meet environmental requirements, ST offers these devices in different grades of ECOPACK® packages, depending on their level of environmental compliance. ECOPACK® specifications, grade definitions and product status are available at: [www.st.com](http://www.st.com).

ECOPACK® is an ST trademark.

Figure 1. UPSD321xx block diagram

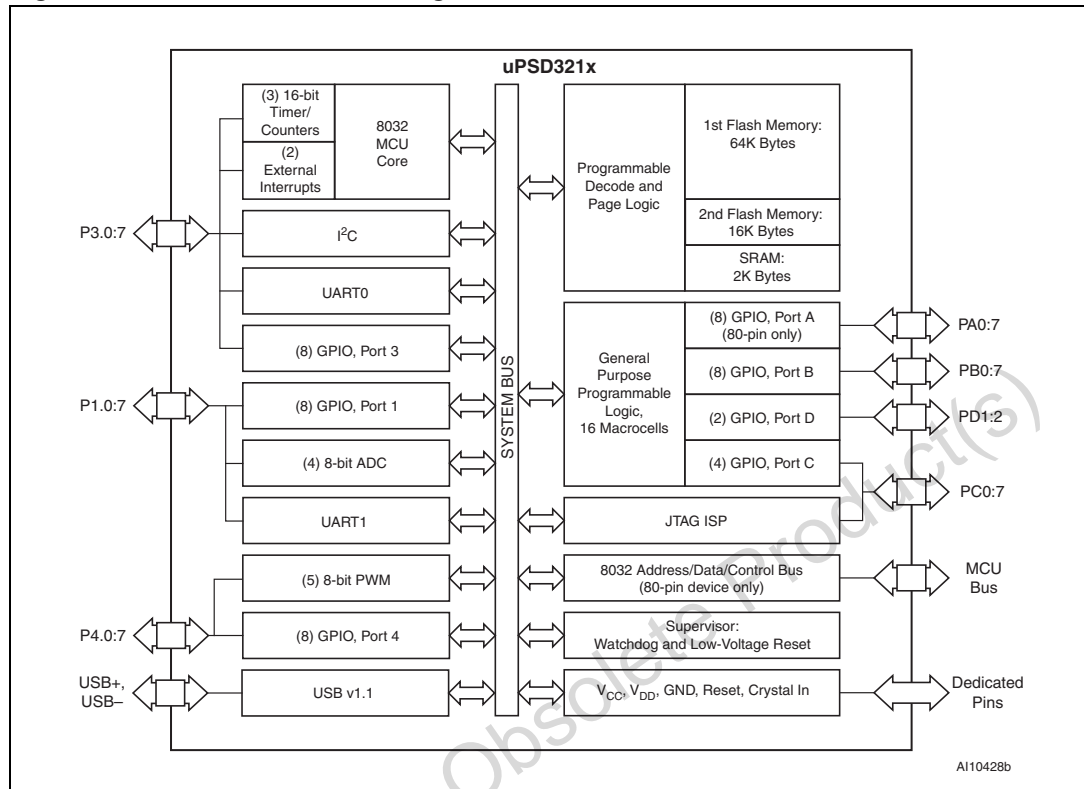

Obsolete Product(s) - Obsolete Product(s)

Figure 2. TQFP52 connections

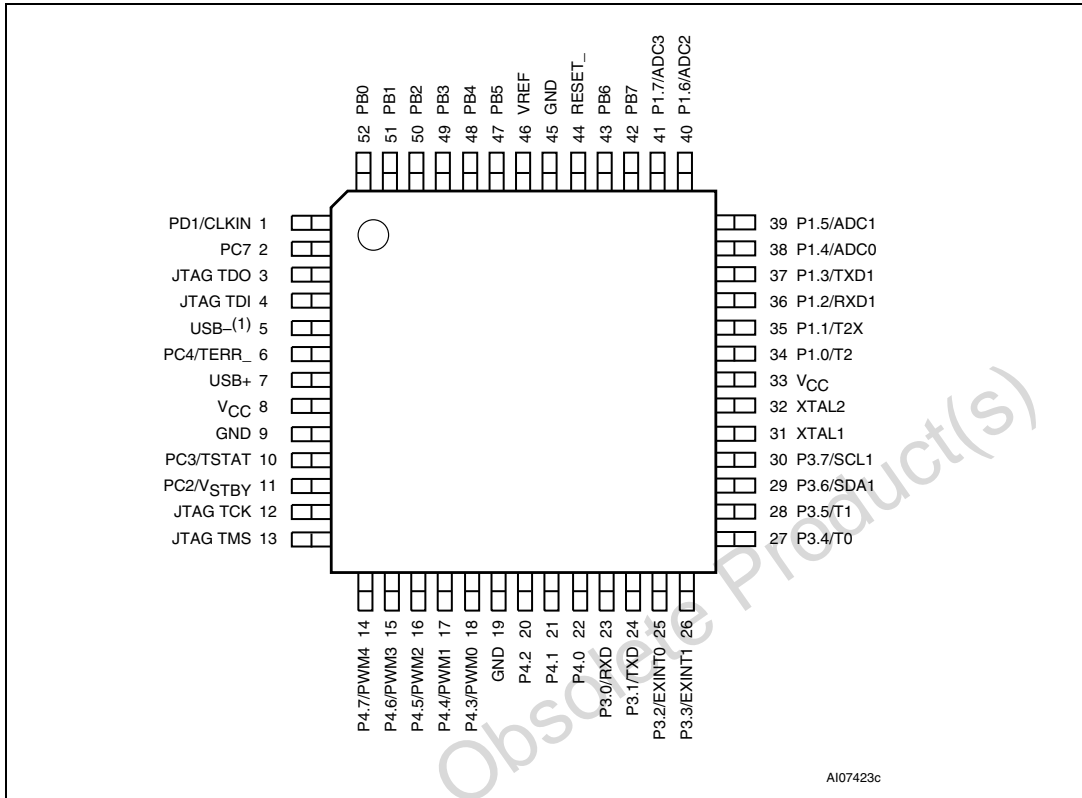

1. Pull-up resistor required on pin 5 (2 kΩ for 3 V devices, 7.5 kΩ for 5 V devices) for all 52-pin devices, with or without USB function.

Figure 3. TQFP80 connections

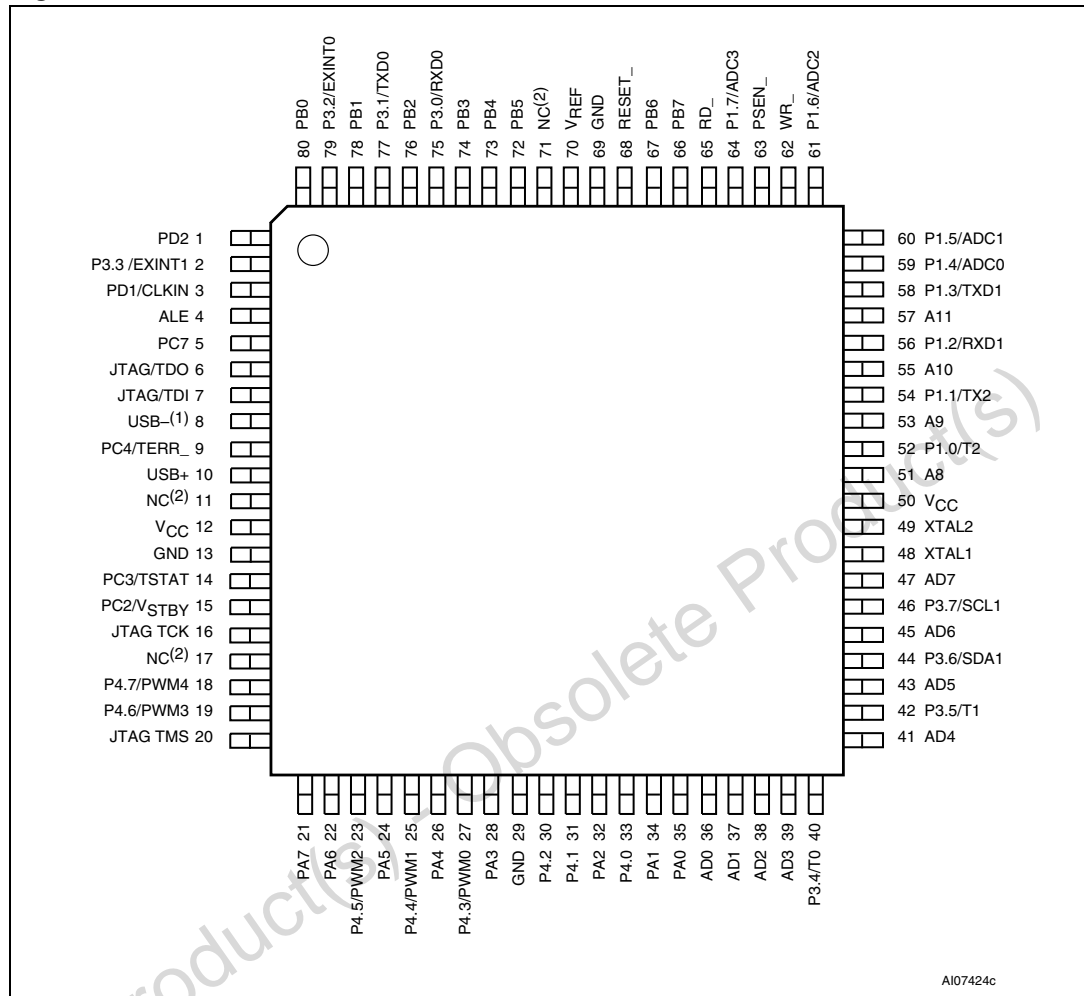

1. Pull-up resistor required on pin 8 (2 kΩ for 3 V devices, 7.5 kΩ for 5 V devices) for all 82-pin devices, with or without USB function.
2. NC = Not Connected

Table 2. 80-pin package pin description

Port pin	Signal name	Pin no.	In/ out	Function	
				Basic	Alternate
	AD0	36	I/O	External Bus: Multiplexed Address/Data bus A1/D1	
	AD1	37	I/O	Multiplexed Address/Data bus A0/D0	
	AD2	38	I/O	Multiplexed Address/Data bus A2/D2	
	AD3	39	I/O	Multiplexed Address/Data bus A3/D3	
	AD4	41	I/O	Multiplexed Address/Data bus A4/D4	
	AD5	43	I/O	Multiplexed Address/Data bus A5/D5	
	AD6	45	I/O	Multiplexed Address/Data bus A6/D6	

**Table 2. 80-pin package pin description (continued)**

Port pin	Signal name	Pin no.	In/ out	Function	
				Basic	Alternate
	AD7	47	I/O	Multiplexed Address/Data bus A7/D7	
P1.0	T2	52	I/O	General I/O port pin	Timer 2 Count input
P1.1	TX2	54	I/O	General I/O port pin	Timer 2 Trigger input
P1.2	RxD1	56	I/O	General I/O port pin	2nd UART Receive
P1.3	TxD1	58	I/O	General I/O port pin	2nd UART Transmit
P1.4	ADC0	59	I/O	General I/O port pin	ADC Channel 0 input
P1.5	ADC1	60	I/O	General I/O port pin	ADC Channel 1 input
P1.6	ADC2	61	I/O	General I/O port pin	ADC Channel 2 input
P1.7	ADC3	64	I/O	General I/O port pin	ADC Channel 3 input
	A8	51	O	External Bus, Address A8	
	A9	53	O	External Bus, Address A9	
	A10	55	O	External Bus, Address A10	
	A11	57	O	External Bus, Address A11	
P3.0	RxD0	75	I/O	General I/O port pin	UART Receive
P3.1	TxD0	77	I/O	General I/O port pin	UART Transmit
P3.2	EXINT0	79	I/O	General I/O port pin	Interrupt 0 input / Timer 0 gate control
P3.3	EXINT1	2	I/O	General I/O port pin	Interrupt 1 input / Timer 1 gate control
P3.4	T0	40	I/O	General I/O port pin	Counter 0 input
P3.5	T1	42	I/O	General I/O port pin	Counter 1 input
P3.6	SDA1	44	I/O	General I/O port pin	I <sup>2</sup> C Bus serial data I/O
P3.7	SCL1	46	I/O	General I/O port pin	I <sup>2</sup> C Bus clock I/O
P4.0	DDC SDA	33	I/O	General I/O port pin	
P4.1	DDC SCL	31	I/O	General I/O port pin	
P4.2	DDC V <sub>SYNC</sub>	30	I/O	General I/O port pin	
P4.3	PWM0	27	I/O	General I/O port pin	8-bit Pulse Width Modulation output 0
P4.4	PWM1	25	I/O	General I/O port pin	8-bit Pulse Width Modulation output 1
P4.5	PWM2	23	I/O	General I/O port pin	8-bit Pulse Width Modulation output 2
P4.6	PWM3	19	I/O	General I/O port pin	8-bit Pulse Width Modulation output 3

**Table 2. 80-pin package pin description (continued)**

Port pin	Signal name	Pin no.	In/ out	Function	
				Basic	Alternate
P4.7	PWM4	18	I/O	General I/O port pin	Programmable 8-bit Pulse Width modulation output 4
	USB-	8	I/O	Pull-up resistor required (2 kΩ for 3 V devices, 7.5 kΩ for 5 V devices)	
	V <sub>REF</sub>	70	O	Reference Voltage input for ADC	
	RD_	65	O	READ signal, external bus	
	WR_	62	O	WRITE signal, external bus	
	PSEN_	63	O	$\overline{\text{PSEN}}$ signal, external bus	
	ALE	4	O	Address Latch signal, external bus	
	RESET_	68	I	Active low $\overline{\text{RESET}}$ input	
	XTAL1	48	I	Oscillator input pin for system clock	
	XTAL2	49	O	Oscillator output pin for system clock	
PA0		35	I/O	General I/O port pin	PLD macrocell outputs PLD inputs Latched address out (A0-A7) Peripheral I/O mode
PA1		34	I/O	General I/O port pin	
PA2		32	I/O	General I/O port pin	
PA3		28	I/O	General I/O port pin	
PA4		26	I/O	General I/O port pin	
PA5		24	I/O	General I/O port pin	
PA6		22	I/O	General I/O port pin	
PA7		21	I/O	General I/O port pin	
PB0		80	I/O	General I/O port pin	PLD macrocell outputs PLD inputs Latched address out (A0-A7)
PB1		78	I/O	General I/O port pin	
PB2		76	I/O	General I/O port pin	
PB3		74	I/O	General I/O port pin	
PB4		73	I/O	General I/O port pin	
PB5		72	I/O	General I/O port pin	
PB6		67	I/O	General I/O port pin	
PB7		66	I/O	General I/O port pin	

**Table 2. 80-pin package pin description (continued)**

Port pin	Signal name	Pin no.	In/ out	Function	
				Basic	Alternate
	JTAG TMS	20	I	JTAG pin	PLD macrocell outputs PLD inputs JTAG pins are dedicated pins
	JTAG TCK	16	I	JTAG pin	
PC3	TSTAT	14	I/O	General I/O port pin	
PC4	TERR_	9	I/O	General I/O port pin	
	JTAG TDI	7	I	JTAG pin	
	JTAG TDO	6	O	JTAG pin	
PC7		5	I/O	General I/O port pin	
PD1	CLKIN	3	I/O	General I/O port pin	PLD I/O Clock input to PLD and APD
PD2		1	I/O	General I/O port pin	PLD I/O Chip select to PSD module
Vcc		12			
Vcc		50			
GND		13			
GND		29			
GND		69			
	USB+	10			
NC		11			
NC		17			
NC		71			

### 1.1 52-pin package I/O port

The 52-pin package members of the UPSD321xx devices have the same port pins as those of the 80-pin package except:

- Port 0 (P0.0-P0.7, external address/data bus AD0-AD7)
- Port 2 (P2.0-P2.3, external address bus A8-A11)
- Port A (PA0-PA7)
- Port D (PD2)
- Bus control signal (RD,WR,PSEN,ALE)
- Pin 5 requires a pull-up resistor (2 kΩ for 3 V devices, 7.5 kΩ for 5 V devices) for all devices, with or without USB function.

## 2 Architecture overview

### 2.1 Memory organization

The UPSD321xx devices' standard 8032 Core has separate 64-Kbyte address spaces for Program memory and Data Memory. Program memory is where the 8032 executes instructions from. Data memory is used to hold data variables. Flash memory can be mapped in either program or data space. The Flash memory consists of two Flash memory blocks: the main Flash memory (512 Kbit) and the Secondary Flash memory (128 Kbit). Except during flash memory programming or update, Flash memory can only be read, not written to. A Page Register is used to access memory beyond the 64-Kbyte address space. Refer to the PSD module for details on mapping of the Flash memory.

The 8032 core has two types of data memory (internal and external) that can be read and written. The internal SRAM consists of 256 bytes, and includes the stack area.

The SFR (Special Function Registers) occupies the upper 128 bytes of the internal SRAM, the registers can be accessed by Direct addressing only. Another 2 Kbytes resides in the PSD module that can be mapped to any address space defined by the user.

Figure 4. Memory map and address space

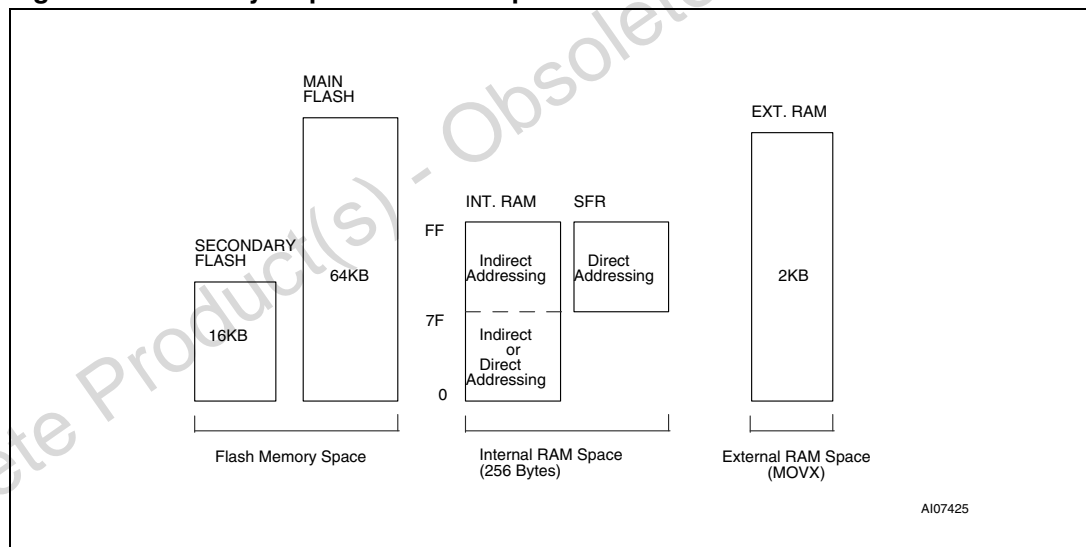

### 2.2 Registers

The 8032 has several registers; these are the Program Counter (PC), Accumulator (A), B Register (B), the Stack Pointer (SP), the Program Status Word (PSW), General purpose registers (R0 to R7), and DPTR (Data Pointer register).



**Figure 5. 8032 MCU registers**

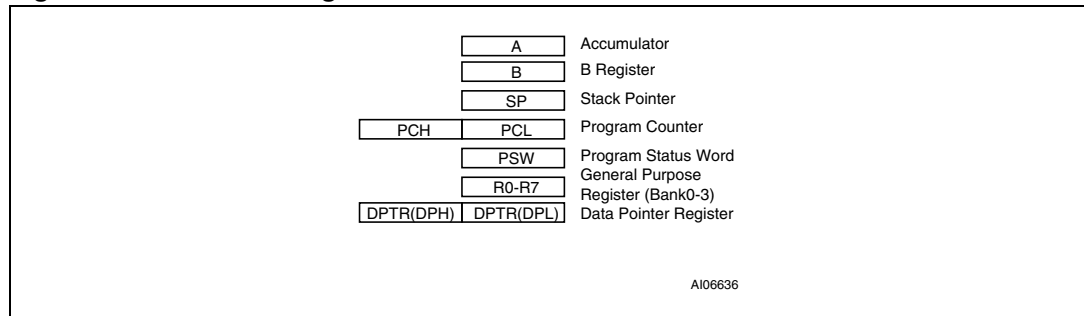

**2.2.1 Accumulator**

The Accumulator is the 8-bit general purpose register, used for data operation such as transfer, temporary saving, and conditional tests. The Accumulator can be used as a 16-bit register with B Register as shown below.

**Figure 6. Configuration of BA 16-bit registers**

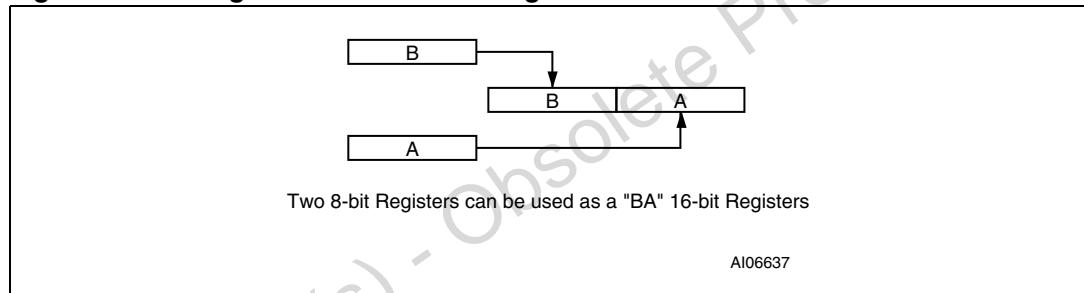

**2.2.2 B register**

The B Register is the 8-bit general purpose register, used for an arithmetic operation such as multiply, division with Accumulator.

**2.2.3 Stack pointer**

The Stack Pointer Register is 8 bits wide. It is incremented before data is stored during PUSH and CALL executions. While the stack may reside anywhere in on-chip RAM, the Stack Pointer is initialized to 07h after reset. This causes the stack to begin at location 08h.

**Figure 7. Stack pointer**

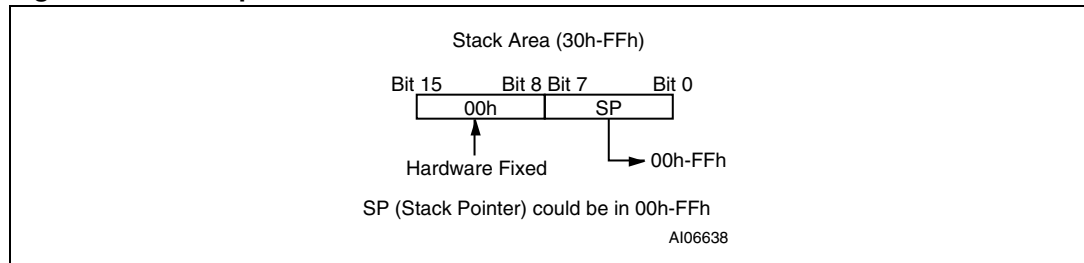

### 2.2.4 Program counter

The Program Counter is a 16-bit wide which consists of two 8-bit registers, PCH and PCL. This counter indicates the address of the next instruction to be executed. In  $\overline{\text{RESET}}$  state, the program counter has reset routine address (PCH:00h, PCL:00h).

### 2.2.5 Program status word

The Program Status Word (PSW) contains several bits that reflect the current state of the CPU and select Internal RAM (00h to 1Fh: Bank0 to Bank3). The PSW is described in *Figure 8*. It contains the Carry flag, the Auxiliary Carry flag, the Half Carry (for BCD operation), the General Purpose flag, the Register Bank Select flags, the Overflow flag, and Parity flag.

[Carry flag, CY]. This flag stores any carry or not borrow from the ALU of CPU after an arithmetic operation and is also changed by the Shift Instruction or Rotate Instruction.

[Auxiliary Carry flag, AC]. After operation, this flag is set when there is a carry from Bit 3 of ALU or there is no borrow from Bit 4 of ALU.

[Register Bank Select flags, RS0, RS1]. These flags select one of four banks (00~07H:bank0, 08~0Fh:bank1, 10~17h:bank2, 17~1Fh:bank3) in Internal RAM.

[Overflow flag, OV]. This flag is set to '1' when an overflow occurs as the result of an arithmetic operation involving signs. An overflow occurs when the result of an addition or subtraction exceeds +127 (7Fh) or -128 (80h). The CLR V instruction clears the overflow flag. There is no set instruction. When the BIT instruction is executed, Bit 6 of memory is copied to this flag.

[Parity flag, P]. This flag reflects the number of Accumulator's 1. If the number of Accumulator's 1 is odd, P=0; otherwise, P=1. The sum when adding Accumulator's 1 to P is always even.

### 2.2.6 Registers R0~R7

General purpose 8-bit registers that are locked in the lower portion of internal data area.

### 2.2.7 Data pointer register

Data Pointer Register is 16-bit wide which consists of two-8bit registers, DPH and DPL. This register is used as a data pointer for the data transmission with external data memory in the PSD module.

**Figure 8. PSW (Program Status Word) register**

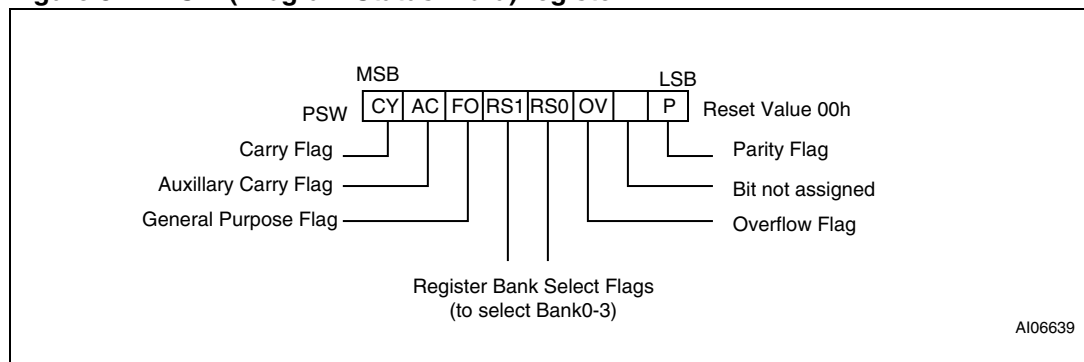

## 2.3 Program memory

The program memory consists of two Flash memories: the main Flash memory (64 Kbit) and the Secondary Flash memory (16 Kbit). The Flash memory can be mapped to any address space as defined by the user in the PSDsoft Tool. It can also be mapped to Data memory space during Flash memory update or programming.

After reset, the CPU begins execution from location 0000h. As shown in [Figure 9](#), each interrupt is assigned a fixed location in Program Memory. The interrupt causes the CPU to jump to that location, where it commences execution of the service routine. External Interrupt 0, for example, is assigned to location 0003h. If External Interrupt 0 is going to be used, its service routine must begin at location 0003h. If the interrupt is not going to be used, its service location is available as general purpose Program Memory.

The interrupt service locations are spaced at 8-byte intervals: 0003h for External Interrupt 0, 000Bh for Timer 0, 0013h for External Interrupt 1, 001Bh for Timer 1 and so forth. If an interrupt service routine is short enough (as is often the case in control applications), it can reside entirely within that 8-byte interval. Longer service routines can use a jump instruction to skip over subsequent interrupt locations, if other interrupts are in use.

## 2.4 Data memory

The internal data memory is divided into four physically separated blocks: 256 bytes of internal RAM, 128 bytes of Special Function Registers (SFRs) areas and 2 Kbytes (XRAM-PSD) in the PSD module.

## 2.5 RAM

Four register banks, each 8 registers wide, occupy locations 0 through 31 in the lower RAM area. Only one of these banks may be enabled at a time. The next 16 bytes, locations 32 through 47, contain 128 directly addressable bit locations. The stack depth is only limited by the available internal RAM space of 256 bytes.

**Figure 9. Interrupt location of program memory**

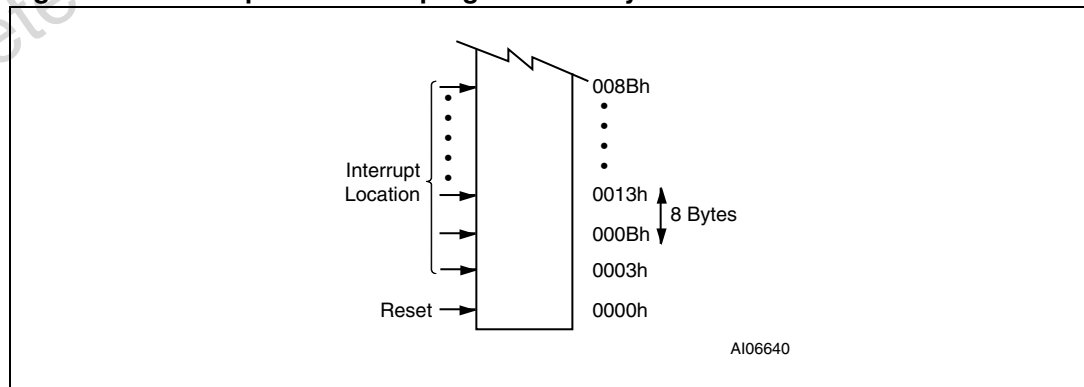

AI06640

## 2.6 XRAM-PSD

The 2 Kbytes of XRAM-PSD resides in the PSD module and can be mapped to any address space through the DPLD (Decoding PLD) as defined by the user in PSDsoft Development tool.

## 2.7 SFR

The SFRs can only be addressed directly in the address range from 80h to FFh. [Table 15](#) gives an overview of the Special Function Registers. Sixteen address in the SFRs space are both-byte and bit-addressable. The bit-addressable SFRs are those whose address ends in 0h and 8h. The bit addresses in this area are 80h to FFh.

**Table 3. RAM address**

Byte address (in hexadecimal)	Bit address (hex)								Byte address (in decimal)
	MSB							LSB	
-									-
FFh									255
30h									48
2Fh	7F	7E	7D	7C	7B	7A	79	78	47
2Eh	77	76	75	74	73	72	71	70	46
2Dh	6F	6E	6D	6C	6B	6A	69	68	45
2Ch	67	66	65	64	63	62	61	60	44
2Bh	5F	5E	5D	5C	5B	5A	59	58	43
2Ah	57	56	55	54	53	52	51	50	42
29h	4F	4E	4D	4C	4B	4A	49	48	41
28h	47	46	45	44	43	42	41	40	40
27h	3F	3E	3D	3C	3B	3A	39	38	39
26h	37	36	35	34	33	32	31	30	38
25h	2F	2E	2D	2C	2B	2A	29	28	37
24h	27	26	25	24	23	22	21	20	36
23h	1F	1E	1D	1C	1B	1A	19	18	35
22h	17	16	15	14	13	12	11	10	34
21h	0F	0E	0D	0C	0B	0A	09	08	33
20h	07	06	05	04	03	02	01	00	32
1Fh	Register bank 3								31
18h	Register bank 3								24
17h	Register bank 2								23
10h	Register bank 2								16
0Fh	Register bank 1								15
08h	Register bank 1								8
07h	Register bank 0								7
00h	Register bank 0								0

## 2.8 Addressing modes

The addressing modes in UPSD321xx devices instruction set are as follows

1. Direct addressing
2. Indirect addressing
3. Register addressing
4. Register-specific addressing
5. Immediate constants addressing
6. Indexed addressing

### 2.8.1 Direct addressing

In a direct addressing the operand is specified by an 8-bit address field in the instruction. Only internal Data RAM and SFRs (80~FFH RAM) can be directly addressed.

Example:

```
mov A, 3EH ; A <----- RAM[3E]
```

**Figure 10. Direct addressing**

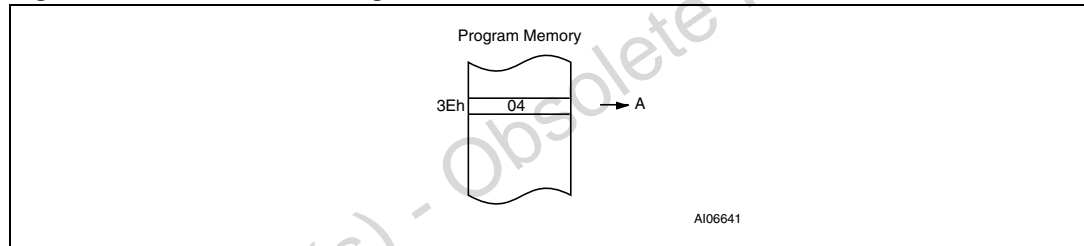

### 2.8.2 Indirect addressing

In indirect addressing the instruction specifies a register which contains the address of the operand. Both internal and external RAM can be indirectly addressed. The address register for 8-bit addresses can be R0 or R1 of the selected register bank, or the Stack Pointer. The address register for 16-bit addresses can only be the 16-bit “data pointer” register, DPTR.

Example:

```
mov @R1, #40 H ;[R1] <-----40H
```

**Figure 11. Indirect addressing**

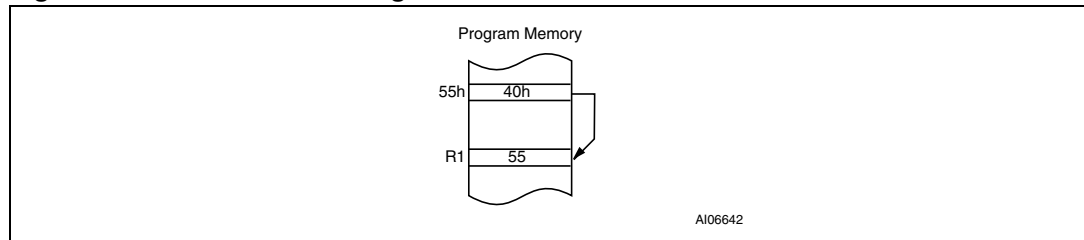

### 2.8.3 Register addressing

The register banks, containing registers R0 through R7, can be accessed by certain instructions which carry a 3-bit register specification within the opcode of the instruction. Instructions that access the registers this way are code efficient, since this mode eliminates an address byte. When the instruction is executed, one of four banks is selected at execution time by the two bank select bits in the PSW.

Example:

```
mov PSW, #0001000B ; select Bank0
mov A, #30H
mov R1, A
```

### 2.8.4 Register-specific addressing

Some instructions are specific to a certain register. For example, some instructions always operate on the Accumulator, or Data Pointer, etc., so no address byte is needed to point it. The opcode itself does that.

### 2.8.5 Immediate constants addressing

The value of a constant can follow the opcode in Program memory.

Example:

```
mov A, #10H.
```

### 2.8.6 Indexed addressing

Only Program memory can be accessed with indexed addressing, and it can only be read. This addressing mode is intended for reading look-up tables in Program memory. A 16-bit base register (either DPTR or PC) points to the base of the table, and the Accumulator is set up with the table entry number. The address of the table entry in Program memory is formed by adding the Accumulator data to the base pointer.

Example:

```
movc A, @A+DPTR
```

Figure 12. Indexed addressing

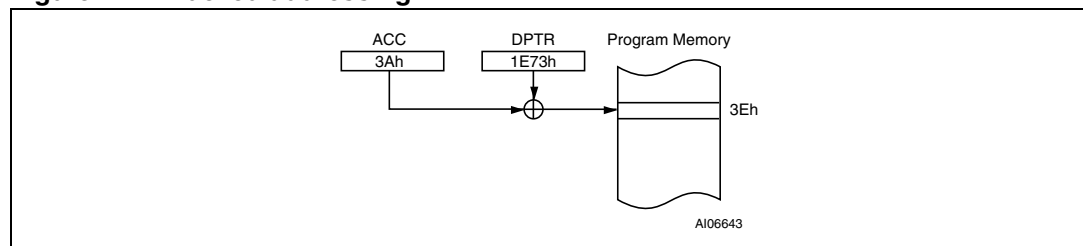

## 2.9 Arithmetic instructions

The arithmetic instructions is listed in [Table 4](#). The table indicates the addressing modes that can be used with each instruction to access the <byte> operand. For example, the ADD A, <byte> instruction can be written as:

ADD a, 7FH (direct addressing)  
 ADD A, @R0 (indirect addressing)  
 ADD a, R7 (register addressing)  
 ADD A, #127 (immediate constant)

*Note:* Any byte in the internal Data Memory space can be incremented without going through the Accumulator.

One of the INC instructions operates on the 16-bit Data Pointer. The Data Pointer is used to generate 16-bit addresses for external memory, so being able to increment it in one 16-bit operation is a useful feature.

The MUL AB instruction multiplies the Accumulator by the data in the B register and puts the 16-bit product into the concatenated B and Accumulator registers.

The DIV AB instruction divides the Accumulator by the data in the B register and leaves the 8-bit quotient in the Accumulator, and the 8-bit remainder in the B register.

In shift operations, dividing a number by  $2^n$  shifts its “n” bits to the right. Using DIV AB to perform the division completes the shift in 4’s and leaves the B register holding the bits that were shifted out. The DAA instruction is for BCD arithmetic operations. In BCD arithmetic, ADD and ADDC instructions should always be followed by a DAA operation, to ensure that the result is also in BCD.

*Note:* DAA will not convert a binary number to BCD. The DAA operation produces a meaningful result only as the second step in the addition of two BCD bytes.

**Table 4. Arithmetic instructions**

Mnemonic	Operation	Addressing modes			
		Dir.	Ind.	Reg.	Imm.
ADD A,<byte>	$A = A + \text{<byte>}$	X	X	X	X
ADDC A,<byte>	$A = A + \text{<byte>} + C$	X	X	X	X
SUBB A,<byte>	$A = A - \text{<byte>} - C$	X	X	X	X
INC	$A = A + 1$	Accumulator only			
INC <byte>	$\text{<byte>} = \text{<byte>} + 1$	X	X	X	
INC DPTR	$\text{DPTR} = \text{DPTR} + 1$	Data Pointer only			
DEC	$A = A - 1$	Accumulator only			
DEC <byte>	$\text{<byte>} = \text{<byte>} - 1$	X	X	X	
MUL AB	$B:A = B \times A$	Accumulator and B only			
DIV AB	$A = \text{Int}[ A / B ]$ $B = \text{Mod}[ A / B ]$	Accumulator and B only			
DA A	Decimal Adjust	Accumulator only			

## 2.10 Logical instructions

[Table 5](#) lists logical instructions for UPSD321xx devices. The instructions that perform Boolean operations (AND, OR, Exclusive OR, NOT) on bytes perform the operation on a bit-by-bit basis. That is, if the Accumulator contains 00110101B and byte contains 01010011B, then:

```
ANL A, <byte>
```

will leave the Accumulator holding 00010001B.

The addressing modes that can be used to access the <byte> operand are listed in [Table 5](#).

The ANL A, <byte> instruction may take any of the forms:

```
ANL A,7FH(direct addressing)
```

```
ANL A, @R1 (indirect addressing)
```

```
ANL A,R6 (register addressing)
```

```
ANL A,#53H (immediate constant)
```

*Note:* Boolean operations can be performed on any byte in the internal Data Memory space without going through the Accumulator. The XRL <byte>, #data instruction, for example, offers a quick and easy way to invert port bits, as in:

```
XRL P1, #0FFH.
```

If the operation is in response to an interrupt, not using the Accumulator saves the time and effort to push it onto the stack in the service routine.

The Rotate instructions (RL A, RLC A, etc.) shift the Accumulator 1 bit to the left or right. For a left rotation, the MSB rolls into the LSB position. For a right rotation, the LSB rolls into the MSB position.

The SWAP A instruction interchanges the high and low nibbles within the Accumulator. This is a useful operation in BCD manipulations. For example, if the Accumulator contains a binary number which is known to be less than 100, it can be quickly converted to BCD by the following code:

```
MOVE B,#10
```

```
DIV AB
```

```
SWAP A
```

```
ADD A,B
```

Dividing the number by 10 leaves the tens digit in the low nibble of the Accumulator, and the ones digit in the B register. The SWAP and ADD instructions move the tens digit to the high nibble of the Accumulator, and the ones digit to the low nibble.

**Table 5. Logical instructions**

Mnemonic	Operation	Addressing modes			
		Dir.	Ind.	Reg.	Imm.
ANL A,<byte>	A = A .AND. <byte>	X	X	X	X
ANL <byte>,A	A = <byte> .AND. A	X			
ANL <byte>,#data	A = <byte> .AND. #data	X			
ORL A,<byte>	A = A .OR. <byte>	X	X	X	X



Table 5. Logical instructions

Mnemonic	Operation	Addressing modes			
		Dir.	Ind.	Reg.	Imm.
ORL <byte>,A	A = <byte> .OR. A	X			
ORL <byte>,#data	A = <byte> .OR. #data	X			
XRL A,<byte>	A = A .XOR. <byte>	X	X	X	X
XRL <byte>,A	A = <byte> .XOR. A	X			
XRL <byte>,#data	A = <byte> .XOR. #data	X			
CRL A	A = 00h	Accumulator only			
CPL A	A = .NOT. A	Accumulator only			
RL A	Rotate A Left 1 bit	Accumulator only			
RLC A	Rotate A Left through Carry	Accumulator only			
RR A	Rotate A Right 1 bit	Accumulator only			
RRC A	Rotate A Right through Carry	Accumulator only			
SWAP A	Swap Nibbles in A	Accumulator only			

## 2.11 Data transfers

### 2.11.1 Internal RAM

*Table 6* shows the menu of instructions that are available for moving data around within the internal memory spaces, and the addressing modes that can be used with each one. The MOV <dest>, <src> instruction allows data to be transferred between any two internal RAM or SFR locations without going through the Accumulator. Remember, the Upper 128 bytes of data RAM can be accessed only by indirect addressing, and SFR space only by direct addressing.

*Note:* In UPSD321xx devices, the stack resides in on-chip RAM, and grows upwards. The PUSH instruction first increments the Stack Pointer (SP), then copies the byte into the stack. PUSH and POP use only direct addressing to identify the byte being saved or restored, but the stack itself is accessed by indirect addressing using the SP register. This means the stack can go into the Upper 128 bytes of RAM, if they are implemented, but not into SFR space.

The Data Transfer instructions include a 16-bit MOV that can be used to initialize the Data Pointer (DPTR) for look-up tables in Program Memory.

The XCH A, <byte> instruction causes the Accumulator and addressed byte to exchange data. The XCHD A, @Ri instruction is similar, but only the low nibbles are involved in the exchange. To see how XCH and XCHD can be used to facilitate data manipulations, consider first the problem of shifting and 8-digit BCD number two digits to the right. *Table 8* shows how this can be done using XCH instructions. To aid in understanding how the code works, the contents of the registers that are holding the BCD number and the content of the Accumulator are shown alongside each instruction to indicate their status after the instruction has been executed.

After the routine has been executed, the Accumulator contains the two digits that were shifted out on the right. Doing the routine with direct MOVs uses 14 code bytes. The same operation with XCHs uses only 9 bytes and executes almost twice as fast. To right-shift by an odd number of digits, a one-digit must be executed. [Table 9](#) shows a sample of code that will right-shift a BCD number one digit, using the XCHD instruction. Again, the contents of the registers holding the number and of the accumulator are shown alongside each instruction.

**Table 6. Data transfer instructions that access internal data memory space**

Mnemonic	Operation	Addressing modes			
		Dir.	Ind.	Reg.	Imm.
MOV A,<src>	A = <src>	X	X	X	X
MOV <dest>,A	<dest> = A	X	X	X	
MOV <dest>,<src>	<dest> = <src>	X	X	X	X
MOV DPTR,#data16	DPTR = 16-bit immediate constant				X
PUSH <src>	INC SP; MOV “@SP”,<src>	X			
POP <dest>	MOV <dest>,”@SP”; DEC SP	X			
XCH A,<byte>	Exchange contents of A and <byte>	X	X	X	
XCHD A,@Ri	Exchange low nibbles of A and @Ri		X		

First, pointers R1 and R0 are set up to point to the two bytes containing the last four BCD digits. Then a loop is executed which leaves the last byte, location 2EH, holding the last two digits of the shifted number. The pointers are decremented, and the loop is repeated for location 2DH. The CJNE instruction (Compare and Jump if Not equal) is a loop control that will be described later. The loop executed from LOOP to CJNE for R1 = 2EH, 2DH, 2CH, and 2BH. At that point the digit that was originally shifted out on the right has propagated to location 2AH. Since that location should be left with 0s, the lost digit is moved to the Accumulator.

**Table 7. Shifting a BCD number 2 digits to the right (using direct MOVs: 14 bytes)**

		2A	2B	2C	2D	2E	ACC
MOV	A,2Eh	00	12	34	56	78	78
MOV	2Eh,2Dh	00	12	34	56	56	78
MOV	2Dh,2Ch	00	12	34	34	56	78
MOV	2Ch,2Bh	00	12	12	34	56	78
MOV	2Bh,#0	00	00	12	34	56	78

**Table 8. Shifting a BCD number 2 digits to the right (using direct XCHs: 9 bytes)**

		2A	2B	2C	2D	2E	ACC
CLR	A	00	12	34	56	78	00
XCH	A,2Bh	00	00	34	56	78	12
XCH	A,2Ch	00	00	12	56	78	34
XCH	A,2Dh	00	00	12	34	78	56
XCH	A,2Eh	00	00	12	34	56	78

**Table 9. Shifting a BCD number one digit to the right**

			2A	2B	2C	2D	2E	ACC
MOV	R1,#2Eh		00	12	34	56	78	xx
MOV	R0,#2Dh		00	12	34	56	78	xx
; loop for R1 = 2Eh								
LOOP:	MOV	A,@R1	00	12	34	56	78	78
	XCHD	A,@R0	00	12	34	58	78	76
	SWAP	A	00	12	34	58	78	67
	MOV	@R1,A	00	12	34	58	67	67
	DEC	R1	00	12	34	58	67	67
	DEC	R0	00	12	34	58	67	67
	CNJE	R1,#2Ah,LOOP	00	12	34	58	67	67
; loop for R1 = 2Dh			00	12	38	45	67	45
; loop for R1 = 2Ch			00	18	23	45	67	23
; loop for R1 = 2Bh			08	01	23	45	67	01
	CLR	A	08	01	23	45	67	00
	XCH	A,2Ah	00	01	23	45	67	08

### 2.11.2 External RAM

*Table 10* shows a list of the Data Transfer instructions that access external Data Memory. Only indirect addressing can be used. The choice is whether to use a one-byte address, @Ri, where Ri can be either R0 or R1 of the selected register bank, or a two-byte address, @DTPR.

*Note:* In all external Data RAM accesses, the Accumulator is always either the destination or source of the data.

### 2.11.3 Lookup tables

*Table 11* shows the two instructions that are available for reading lookup tables in Program Memory. Since these instructions access only Program Memory, the lookup tables can only be read, not updated.

The mnemonic is MOVC for “move constant.” The first MOVC instruction in *Table 11* can accommodate a table of up to 256 entries numbered 0 through 255. The number of the desired entry is loaded into the Accumulator, and the Data Pointer is set up to point to the beginning of the table. Then:

```
MOVC A, @A+DPTR
```

copies the desired table entry into the Accumulator.

The other MOVC instruction works the same way, except the Program Counter (PC) is used as the table base, and the table is accessed through a subroutine. First the number of the desired en-try is loaded into the Accumulator, and the subroutine is called:

```
MOV A, ENTRY NUMBER
CALL TABLE
```

The subroutine “TABLE” would look like this:

```
TABLE: MOVC A, @A+PC
RET
```

The table itself immediately follows the RET (return) instruction in Program Memory. This type of table can have up to 255 entries, numbered 1 through 255. Number 0 cannot be used, because at the time the MOVC instruction is executed, the PC contains the address of the RET instruction. An entry numbered 0 would be the RET opcode itself.

**Table 10. Data transfer instruction that access external data memory space**

Address Width	Mnemonic	Operation
8 bits	MOVX A, @Ri	READ external RAM @Ri
8 bits	MOVX @Ri, A	WRITE external RAM @Ri
16 bits	MOVX A, @DPTR	READ external RAM @DPTR
16 bits	MOVX @DPTR, a	WRITE external RAM @DPTR

**Table 11. Lookup table READ instruction**

Mnemonic	Operation
MOVC A, @A+DPTR	READ program memory at (A+DPTR)
MOVC A, @A+PC	READ program memory at (A+PC)

## 2.12 Boolean instructions

The UPSD321xx devices contain a complete Boolean (single-bit) processor. One page of the internal RAM contains 128 address-able bits, and the SFR space can support up to 128 addressable bits as well. All of the port lines are bit-addressable, and each one can be treated as a separate single-bit port. The instructions that access these bits are not just conditional branches, but a complete menu of move, set, clear, complement, OR and AND instructions. These kinds of bit operations are not easily obtained in other architectures with any amount of byte-oriented software.

The instruction set for the Boolean processor is shown in [Table 12](#). All bits accesses are by direct addressing.

Bit addresses 00h through 7Fh are in the Lower 128, and bit addresses 80h through FFh are in SFR space.

Note how easily an internal flag can be moved to a port pin:

```
MOV C,FLAG
MOV P1.0,C
```

In this example, FLAG is the name of any addressable bit in the Lower 128 or SFR space. An I/O line (the LSB of Port 1, in this case) is set or cleared depending on whether the Flag bit is '1' or '0.'

The Carry Bit in the PSW is used as the single-bit Accumulator of the Boolean processor. Bit instructions that refer to the Carry Bit as C assemble as Carry-specific instructions (CLR C, etc.). The Carry Bit also has a direct address, since it resides in the PSW register, which is bit-addressable.

*Note:* The Boolean instruction set includes ANL and ORL operations, but not the XRL (Exclusive OR) operation. An XRL operation is simple to implement in software. Suppose, for example, it is required to form the Exclusive OR of two bits:

```
C = bit 1 .XRL. bit2
```

The software to do that could be as follows:

```
MOV C , bit1
JNB bit2, OVER
CPL C
OVER: (continue)
```

First, Bit 1 is moved to the Carry. If bit2 = 0, then C now contains the correct result. That is, Bit 1 .XRL. bit2 = bit1 if bit2 = 0. On the other hand, if bit2 = 1, C now contains the complement of the correct result. It need only be inverted (CPL C) to complete the operation.

This code uses the JNB instruction, one of a series of bit-test instructions which execute a jump if the addressed bit is set (JC, JB, JBC) or if the addressed bit is not set (JNC, JNB). In the above case, Bit 2 is being tested, and if bit2 = 0, the CPL C instruction is jumped over.

JBC executes the jump if the addressed bit is set, and also clears the bit. Thus a flag can be tested and cleared in one operation. All the PSW bits are directly addressable, so the Parity Bit, or the general-purpose flags, for example, are also available to the bit-test instructions.

**Table 12. Boolean instructions**

Mnemonic	Operation
ANL C,bit	C = A .AND. bit
ANL C,/bit	C = C .AND. .NOT. bit
ORL C,bit	C = A .OR. bit
ORL C,/bit	C = C .OR. .NOT. bit
MOV C,bit	C = bit
MOV bit,C	bit = C
CLR C	C = 0
CLR bit	bit = 0
SETB C	C = 1
SETB bit	bit = 1
CPL C	C = .NOT. C
CPL bit	bit = .NOT. bit
JC rel	Jump if C = 1
JNC rel	Jump if C = 0
JB bit,rel	Jump if bit = 1
JNB bit,rel	Jump if bit = 0
JBC bit,rel	Jump if bit = 1; CLR bit

## 2.13 Relative offset

The destination address for these jumps is specified to the assembler by a label or by an actual address in Program memory. However, the destination address assembles to a relative offset byte. This is a signed (two's complement) offset byte which is added to the PC in two's complement arithmetic if the jump is executed.

The range of the jump is therefore -128 to +127 Program Memory bytes relative to the first byte following the instruction.

## 2.14 Jump instructions

[Table 13](#) shows the list of unconditional jump instructions. The table lists a single "JMP add" instruction, but in fact there are three SJMP, LJMP, and AJMP, which differ in the format of the destination address. JMP is a generic mnemonic which can be used if the programmer does not care which way the jump is en-coded.

The SJMP instruction encodes the destination address as a relative offset, as described above. The instruction is 2 bytes long, consisting of the opcode and the relative offset byte. The jump distance is limited to a range of -128 to +127 bytes relative to the instruction following the SJMP.

The LJMP instruction encodes the destination address as a 16-bit constant. The instruction is 3 bytes long, consisting of the opcode and two address bytes. The destination address can be anywhere in the 64K Program Memory space.

The AJMP instruction encodes the destination address as an 11-bit constant. The instruction is 2 bytes long, consisting of the opcode, which itself contains 3 of the 11 address bits, followed by another byte containing the low 8 bits of the destination address. When the instruction is executed, these 11 bits are simply substituted for the low 11 bits in the PC. The high 5 bits stay the same. Hence the destination has to be within the same 2K block as the instruction following the AJMP.

In all cases the programmer specifies the destination address to the assembler in the same way: as a label or as a 16-bit constant. The assembler will put the destination address into the correct format for the given instruction. If the format required by the instruction will not support the distance to the specified destination address, a "Destination out of range" message is written into the List file.

The JMP @A+DPTR instruction supports case jumps. The destination address is computed at execution time as the sum of the 16-bit DPTR register and the Accumulator. Typically, DPTR is set up with the address of a jump table. In a 5-way branch, for example, an integer 0 through 4 is loaded into the Accumulator. The code to be executed might be as follows:

```
MOV DPTR,#JUMP_TABLE
MOV A,INDEX_NUMBER
RL A
JMP @A+DPTR
```

The RL A instruction converts the index number (0 through 4) to an even number on the range 0 through 8, because each entry in the jump table is 2 bytes long:

```
JUMP_TABLE:
AJMP CASE_0
AJMP CASE_1
AJMP CASE_2
AJMP CASE_3
AJMP CASE_4
```

[Table 13](#) shows a single "CALL addr" instruction, but there are two of them, LCALL and ACALL, which differ in the format in which the subroutine address is given to the CPU. CALL is a generic mnemonic which can be used if the programmer does not care which way the address is encoded.

The LCALL instruction uses the 16-bit address format, and the subroutine can be anywhere in the 64K Program Memory space. The ACALL instruction uses the 11-bit format, and the subroutine must be in the same 2K block as the instruction following the ACALL.

In any case, the programmer specifies the subroutine address to the assembler in the same way: as a label or as a 16-bit constant. The assembler will put the address into the correct format for the given instructions.

Subroutines should end with a RET instruction, which returns execution to the instruction following the CALL.

RETI is used to return from an interrupt service routine. The only difference between RET and RETI is that RETI tells the interrupt control system that the interrupt in progress is done.

If there is no interrupt in progress at the time RETI is executed, then the RETI is functionally identical to RET.

**Table 13. Unconditional Jump instructions**

Mnemonic	Operation
JMP addr	Jump to addr
JMP @A+DPTR	Jump to A+DPTR
CALL addr	Call Subroutine at addr
RET	Return from subroutine
RETI	Return from interrupt
NOP	No operation

[Table 14](#) shows the list of conditional jumps available to the UPSD321xx device user. All of these jumps specify the destination address by the relative offset method, and so are limited to a jump distance of -128 to +127 bytes from the instruction following the conditional jump instruction. Important to note, however, the user specifies to the assembler the actual destination address the same way as the other jumps: as a label or a 16-bit constant.

There is no Zero Bit in the PSW. The JZ and JNZ instructions test the Accumulator data for that condition.

The DJNZ instruction (Decrement and Jump if Not Zero) is for loop control. To execute a loop N times, load a counter byte with N and terminate the loop with a DJNZ to the beginning of the loop, as shown below for N = 10:

```

MOV COUNTER,#10
LOOP: (begin loop)
    .
    .
    .
(end loop)
DJNZ COUNTER, LOOP
(continue)

```

The CJNE instruction (Compare and Jump if Not Equal) can also be used for loop control as in [Table 9](#). Two bytes are specified in the operand field of the instruction. The jump is executed only if the two bytes are not equal. In the example of [Table 9](#) Shifting a BCD Number One Digits to the Right, the two bytes were data in R1 and the constant 2Ah. The initial data in R1 was 2Eh.

Every time the loop was executed, R1 was decremented, and the looping was to continue until the R1 data reached 2Ah.

Another application of this instruction is in “greater than, less than” comparisons. The two bytes in the operand field are taken as unsigned integers. If the first is less than the second, then the Carry Bit is set (1). If the first is greater than or equal to the second, then the Carry Bit is cleared.



## 2.15 Machine cycles

A machine cycle consists of a sequence of six states, numbered S1 through S6. Each state time lasts for two oscillator periods. Thus, a machine cycle takes 12 oscillator periods or 1µs if the oscillator frequency is 12MHz. Refer to [Table 13: State sequence in UPSD321xx devices](#).

Each state is divided into a Phase 1 half and a Phase 2 half. State Sequence in UPSD321xx devices shows that retrieve/execute sequences in states and phases for various kinds of instructions.

Normally two program retrievals are generated during each machine cycle, even if the instruction being executed does *not* require it. If the instruction being executed does not need more code bytes, the CPU simply ignores the extra retrieval, and the Program Counter is not incremented.

Execution of a one-cycle instruction ([Figure 13: State sequence in UPSD321xx devices](#)) begins during State 1 of the machine cycle, when the opcode is latched into the Instruction Register. A second retrieve occurs during S4 of the same machine cycle. Execution is complete at the end of State 6 of this machine cycle.

The MOVX instructions take two machine cycles to execute. No program retrieval is generated during the second cycle of a MOVX instruction. This is the only time program retrievals are skipped. The retrieve/execute sequence for MOVX instruction is shown in [Figure 13 \(d\)](#).

**Table 14. Conditional jump instructions**

Mnemonic	Operation	Addressing modes			
		Dir.	Ind.	Reg.	Imm.
JZ rel	Jump if A = 0	Accumulator only			
JNZ rel	Jump if A ≠ 0	Accumulator only			
DJNZ <byte>,rel	Decrement and jump if not zero	X		X	
CJNE A,<byte>,rel	Jump if A ≠ <byte>	X			X
CJNE <byte>,#data,rel	Jump if <byte> ≠ #data		X	X	

Figure 13. State sequence in UPSD321xx devices

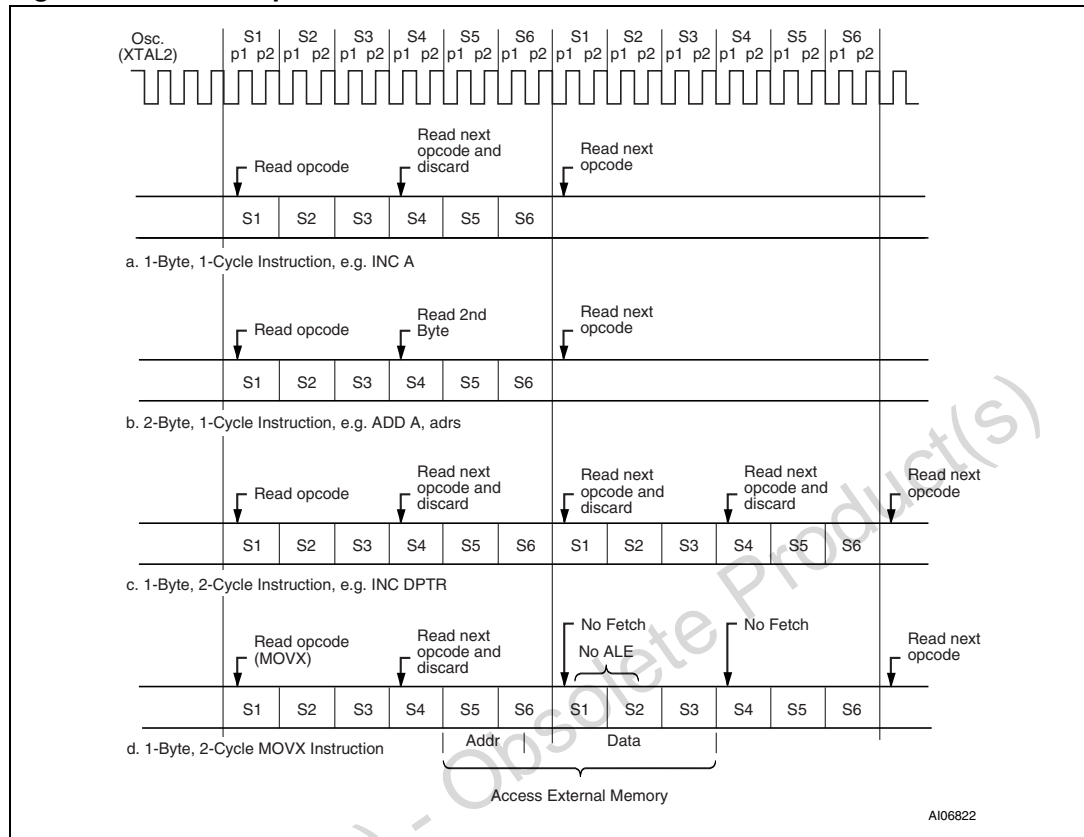

### 3 UPSD321xx hardware description

The UPSD321xx devices have a modular architecture with two main functional modules: the MCU module and the PSD module. The MCU module consists of a standard 8032 core, peripherals and other system supporting functions. The PSD module provides configurable Program and Data memories to the 8032 CPU core. In addition, it has its own set of I/O ports and a PLD with 16 macrocells for general logic implementation. Ports A,B,C, and D are general purpose programmable I/O ports that have a port architecture which is different from Ports 0-4 in the MCU module.

The PSD module communicates with the CPU Core through the internal address, data bus (A0-A15, D0-D7) and control signals (RD\_, WR\_, PSEN\_, ALE, RESET\_). The user defines the Decoding PLD in the PSDsoft Development Tool and can map the resources in the PSD module to any program or data address space.

Figure 14. UPSD321xx functional modules

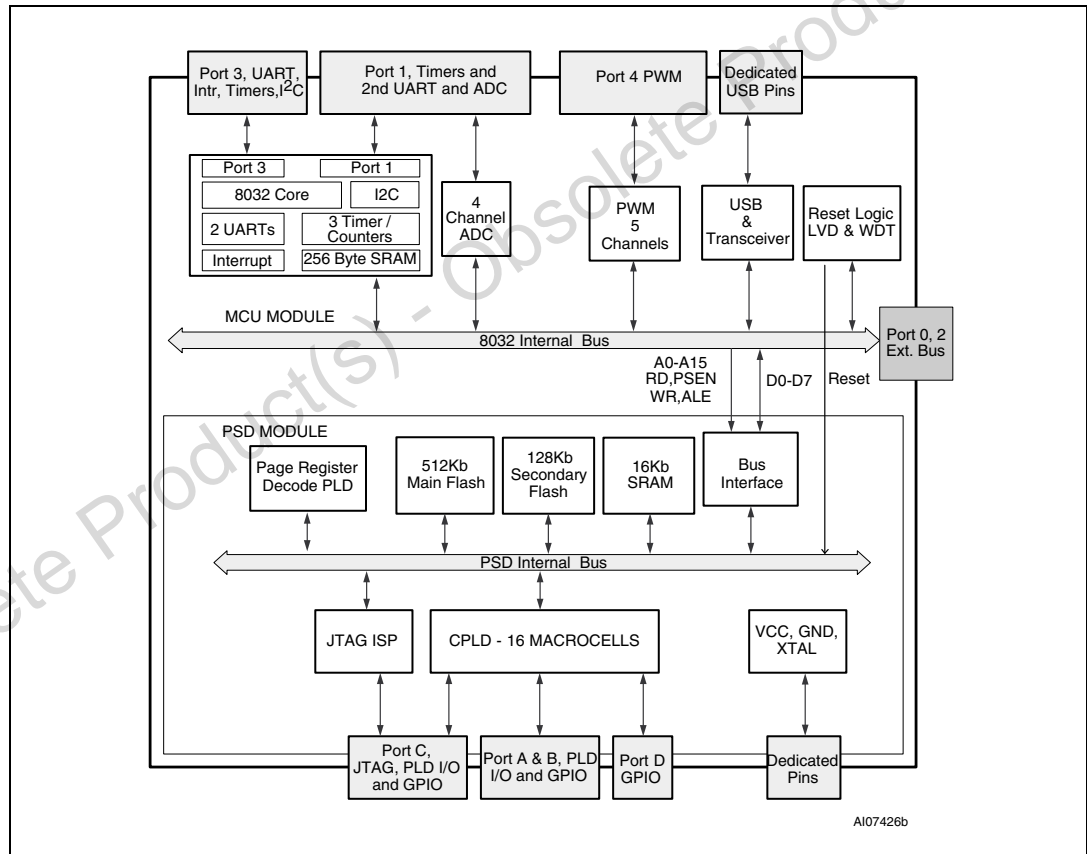

## 4 MCU module description

This section provides a detail description of the MCU module system functions and Peripherals, including:

- Special function registers
- Timers/counter
- Interrupts
- PWM
- Supervisory function (LVD and Watchdog)
- USART
- Power-saving modes
- I<sup>2</sup>C Bus
- On-chip oscillator
- ADC
- I/O Ports

### 4.1 Special function registers

A map of the on-chip memory area called the Special Function Register (SFR) space is shown in [Table 15](#).

*Note:* In the SFRs not all of the addresses are occupied. Unoccupied addresses are not implemented on the chip. READ accesses to these addresses will in general return random data, and WRITE accesses will have no effect. User software should write '0s' to these unimplemented locations.

**Table 15. SFR memory map**

F8									FF
F0	B <sup>(1)</sup>								F7
E8	UISTA <sup>(1)</sup>	UIEN	UCON0	UCON1	UCON2	USTA	UADR	UDR0	EF
E0	ACC <sup>(1)</sup>	USCL					UDT1	UDT0	E7
D8					S2CON	S2STA	S2DAT	S2ADR	DF
D0	PSW <sup>(1)</sup>								D7
C8	T2CON <sup>(1)</sup>	T2MOD	RCAP2L	RCAP2H	TL2	TH2			CF
C0	P4 <sup>(1)</sup>								C7
B8	IP <sup>(1)</sup>								BF
B0	P3 <sup>(1)</sup>	PSCL0L	PSCL0H	PSCL1L	PSCL1H			IPA	B7
A8	IE <sup>(1)</sup>		PWM4P	PWM4W			WDKEY		AF
A0	P2 <sup>(1)</sup>	PWMCON	PWM0	PWM1	PWM2	PWM3	WDRST	IEA	A7
98	SCON	SBUF	SCON2	SBUF2					9F
90	P1 <sup>(1)</sup>	P1SFS		P3SFS	P4SFS	ASCL	ADAT	ACON	97

**Table 15. SFR memory map (continued)**

88	TCON <sup>(1)</sup>	TMOD	TL0	TL1	TH0	TH1			8F
80	P0 <sup>(1)</sup>	SP	DPL	DPH				PCON	87

1. Register can be bit addressing

**Table 16. List of all SFRs**

SFR Addr	Reg Name	Bit Register Name								Reset Value	Comments
		7	6	5	4	3	2	1	0		
80	P0									FF	Port 0
81	SP									07	Stack Ptr
82	DPL									00	Data Ptr Low
83	DPH									00	Data Ptr High
87	PCON	SMOD	SMOD1	LVREN	ADSFINT	RCLK1	TCLK1	PD	IDLE	00	Power Ctrl
88	TCON	TF1	TR1	TF0	TR0	IE1	IT1	IE0	IT0	00	Timer / Cntr Control
89	TMOD	Gate	C/T	M1	M0	Gate	C/T	M1	M0	00	Timer / Cntr mode Control
8A	TL0									00	Timer 0 Low
8B	TL1									00	Timer 1 Low
8C	TH0									00	Timer 0 High
8D	TH1									00	Timer 1 High
90	P1									FF	Port 1
91	P1SFS	P1S7	P1S6	P1S5	P1S4					00	Port 1 Select Register
93	P3SFS	P3S7	P3S6							00	Port 3 Select Register
94	P4SFS	P4S7	P4S6	P4S5	P4S4	P4S3	P4S2	P4S1	P4S0	00	Port 4 Select Register
95	ASCL									00	8-bit Prescaler for ADC clock
96	ADAT	ADAT7	ADAT6	ADAT5	ADAT4	ADAT3	ADAT2	ADAT1	ADAT0	00	ADC Data Register
97	ACON			ADEN		ADS1	ADS0	ADST	ADSF	00	ADC Control Register
98	SCON	SM0	SM1	SM2	REN	TB8	RB8	TI	RI	00	Serial Control Register
99	SBUF									00	Serial Buffer
9A	SCON2	SM0	SM1	SM2	REN	TB8	RB8	TI	RI	00	2nd UART Ctrl Register
9B	SBUF2									00	2nd UART Serial Buffer
A0	P2									FF	Port 2

Table 16. List of all SFRs (continued)

SFR Addr	Reg Name	Bit Register Name								Reset Value	Comments
		7	6	5	4	3	2	1	0		
A1	PWMCON	PWML	PWMP	PWME	CFG4	CFG3	CFG2	CFG1	CFG0	00	PWM Control Polarity
A2	PWM0									00	PWM0 Output Duty Cycle
A3	PWM1									00	PWM1 Output Duty Cycle
A4	PWM2									00	PWM2 Output Duty Cycle
A5	PWM3									00	PWM3 Output Duty Cycle
A6	WDRST									00	Watch Dog Reset
A7	IEA				ES2			EI <sup>2</sup> C		00	Interrupt Enable (2nd)
A8	IE	EA	-	ET2	ES	ET1	EX1	ET0	EX0	00	Interrupt Enable
A9											
AA	PWM4P									00	PWM 4 Period
AB	PWM4W									00	PWM 4 Pulse Width
AE	WDKEY									00	Watch Dog Key Register
B0	P3									FF	Port 3
B1	PSCL0L									00	Prescaler 0 Low (8-bit)
B2	PSCL0H									00	Prescaler 0 High (8-bit)
B3	PSCL1L									00	Prescaler 1 Low (8-bit)
B4	PSCL1H									00	Prescaler 1 High (8-bit)
B7	IPA				PS2			PI <sup>2</sup> C		00	Interrupt Priority (2nd)
B8	IP			PT2	PS	PT1	PX1	PT0	PX0	00	Interrupt Priority
C0	P4									FF	New Port 4
C8	T2CON	TF2	EXF2	RCLK	TCLK	EXEN2	TR2	C/T2	CP/RL2	00	Timer 2 Control

Table 16. List of all SFRs (continued)

SFR Addr	Reg Name	Bit Register Name								Reset Value	Comments
		7	6	5	4	3	2	1	0		
C9	T2MOD								DCEN	00	Timer 2 mode
CA	RCAP2L									00	Timer 2 Reload low
CB	RCAP2H									00	Timer 2 Reload High
CC	TL2									00	Timer 2 Low byte
CD	TH2									00	Timer 2 High byte
D0	PSW	CY	AC	FO	RS1	RS0	OV		P	00	Program Status Word
D2	S2SETUP									00	I <sup>2</sup> C (S2) Setup
DC	S2CON	CR2	EN1	STA	STO	ADDR	AA	CR1	CR0	00	I <sup>2</sup> C Bus Control Reg
DD	S2STA	GC	Stop	Intr	TX-Md	Bbusy	Blost	ACK_R	SLV	00	I <sup>2</sup> C Bus Status
DE	S2DAT									00	Data Hold Register
DF	S2ADR									00	I <sup>2</sup> C address
E0	ACC									00	Accumulator
E1	USCL									00	8-bit Prescaler for USB logic
E6	UDT1	UDT1.7	UDT1.6	UDT1.5	UDT1.4	UDT1.3	UDT1.2	UDT1.1	UDT1.0	00	USB Endpt1 Data Xmit
E7	UDT0	UDT0.7	UDT0.6	UDT0.5	UDT0.4	UDT0.3	UDT0.2	UDT0.1	UDT0.0	00	USB Endpt0 Data Xmit
E8	UISTA	SUSPND	—	RSTF	TXD0F	RXD0F	RXD1F	EOPF	RESUMF	00	USB Interrupt Status
E9	UIEN									00	USB Interrupt Enable
EA	UCON0	TSEQ0	STALL0	TX0E	RX0E	TP0SiZ3	TP0SiZ2	TP0SiZ1	TP0SiZ0	00	USB Endpt0 Xmit Control
EB	UCON1	TSEQ1	EP12SEL	—	FRESUM	TP1SiZ3	TP1SiZ2	TP1SiZ1	TP1SiZ0	00	USB Endpt1 Xmit Control
EC	UCON2	—	—	—	SOUT	EP2E	EP1E	STALL2	STALL1	00	USB Control Register
ED	USTA	RSEQ	SETUP	IN	OUT	RP0SiZ3	RP0SiZ2	RP0SiZ1	RP0SiZ0	00	USB Endpt0 Status
EE	UADR	USBEN	UADD6	UADD5	UADD4	UADD3	UADD2	UADD1	UADD0	00	USB Address Register

**Table 16. List of all SFRs (continued)**

SFR Addr	Reg Name	Bit Register Name								Reset Value	Comments
		7	6	5	4	3	2	1	0		
EF	UDR0	UDR0.7	UDR0.6	UDR0.5	UDR0.4	UDR0.3	UDR0.2	UDR0.1	UDR0.0	00	USB Endpt0 Data Recv
F0	B									00	B Register

**Table 17. PSD module register address offset**

CSIOP addr offset	Register name	Bit register name								Reset value	Comments
		7	6	5	4	3	2	1	0		
00	Data In (Port A)	Reads Port pins as input									
02	Control (Port A)	Configure pin between I/O or Address Out mode. Bit = 0 selects I/O								00	
04	Data Out (Port A)	Latched data for output to Port pins, I/O Output mode								00	
06	Direction (Port A)	Configures Port pin as input or output. Bit = 0 selects input								00	
08	Drive (Port A)	Configures Port pin between CMOS, Open Drain or Slew rate. Bit = 0 selects CMOS								00	
0A	Input Macrocell (Port A)	Reads latched value on Input Macrocells									
0C	Enable Out (Port A)	Reads the status of the output enable control to the Port pin driver. Bit = 0 indicates pin is in input mode.									
01	Data In (Port B)										
03	Control (Port B)									00	
05	Data Out (Port B)									00	
07	Direction (Port B)									00	
09	Drive (Port B)									00	
0B	Input Macrocell (Port B)										
0D	Enable Out (Port B)										
10	Data In (Port C)										
12	Data Out (Port C)									00	
14	Direction (Port C)									00	
16	Drive (Port C)									00	
18	Input Macrocell (Port C)										



Table 17. PSD module register address offset (continued)

CSIOP addr offset	Register name	Bit register name								Reset value	Comments	
		7	6	5	4	3	2	1	0			
1A	Enable Out (Port C)											
11	Data In (Port D)	*	*	*	*	*		*				Only Bit 1 and 2 are used
13	Data Out (Port D)	*	*	*	*	*		*		00		Only Bit 1 and 2 are used
15	Direction (Port D)	*	*	*	*	*		*		00		Only Bit 1 and 2 are used
17	Drive (Port D)	*	*	*	*	*		*		00		Only Bit 1 and 2 are used
1B	Enable Out (Port D)	*	*	*	*	*		*				Only Bit 1 and 2 are used
20	Output Macrocells AB											
21	Output Macrocells BC											
22	Mask Macrocells AB											
23	Mask Macrocells BC											
C0	Primary Flash Protection					Sec3_Prot	Sec2_Prot	Sec1_Prot	Sec0_Prot			Bit = 1 sector is protected
C2	Secondary Flash Protection	Security_Bit	*	*	*	*	*	Sec1_Prot	Sec0_Prot			Security Bit = 1 device is secured
B0	PMMR0	*	*	PLD Mcells clk	PLD array-clk	PLD Turbo	*	APD enable	*	00		Control PLD power consumption
B4	PMMR2	*		PLD array Ale	PLD array Cntl2	PLD array Cntl1	PLD array Cntl0	*	*	00		Blocking inputs to PLD array
E0	Page									00		Page Register
E2	VM	Periph-mode	*	*	FL_data	Boot_data	FL_code	Boot_code	SR_code			Configure 8032 Program and Data Space

1. (Register address = CSIOP address + address offset; where CSIOP address is defined by user in PSDsoft)  
 \* indicates bit is not used and must be set to '0'.

## 5 Interrupt system

There are interrupt requests from 10 sources as follows.

- INT0 external interrupt
- 2nd USART interrupt
- Timer 0 interrupt
- I<sup>2</sup>C interrupt
- INT1 external interrupt (or ADC interrupt)
- Timer 1 interrupt
- USB interrupt
- USART interrupt
- Timer 2 interrupt

### 5.1 External Int0 interrupt

- The INT0 can be either level-active or transition-active depending on Bit IT0 in register TCON. The flag that actually generates this interrupt is Bit IE0 in TCON.
- When an external interrupt is generated, the corresponding request flag is cleared by the hardware when the service routine is vectored to only if the interrupt was transition activated.
- If the interrupt was level activated then the interrupt request flag remains set until the requested interrupt is actually generated. Then it has to deactivate the request before the interrupt service routine is completed, or else another interrupt will be generated.

### 5.2 Timer 0 and 1 interrupts

- Timer 0 and Timer 1 Interrupts are generated by TF0 and TF1 which are set by an overflow of their respective Timer/Counter registers (except for Timer 0 in Mode 3).
- These flags are cleared by the internal hardware when the interrupt is serviced.

### 5.3 Timer 2 interrupt

- Timer 2 Interrupt is generated by TF2 which is set by an overflow of Timer 2. This flag has to be cleared by the software - not by hardware.
- It is also generated by the T2EX signal (Timer 2 External Interrupt P1.1) which is controlled by EXEN2 and EXF2 Bits in the T2CON register.

### 5.4 I<sup>2</sup>C interrupt

- The interrupt of the I<sup>2</sup>C is generated by Bit INTR in the register S2STA.
- This flag is cleared by hardware.

## 5.5 External Int1 interrupt

- The INT1 can be either level active or transition active depending on Bit IT1 in register TCON. The flag that actually generates this interrupt is Bit IE1 in TCON.
- When an external interrupt is generated, the corresponding request flag is cleared by the hardware when the service routine is vectored to only if the interrupt was transition activated.
- If the interrupt was level activated then the interrupt request flag remains set until the requested interrupt is actually generated. Then it has to deactivate the request before the interrupt service routine is completed, or else another interrupt will be generated.
- The ADC can take over the External INT1 to generate an interrupt on conversion being completed

## 5.6 USB interrupt

- The USB interrupt is generated when endpoint0 has transmitted a packet or received a packet, when Endpoint1 or Endpoint2 has transmitted a packet, when the suspend or resume state is detected and every EOP received.
- When the USB interrupt is generated, the corresponding request flag must be cleared by software. The interrupt service routine will have to check the various USB registers to determine the source and clear the corresponding flag.
- Please see the dedicated interrupt control registers for the USB peripheral for more information.

## 5.7 USART interrupt

- The USART Interrupt is generated by RI (receive interrupt) OR TI (transmit interrupt).
- When the USART Interrupt is generated, the corresponding request flag must be cleared by software. The interrupt service routine will have to check the various USART registers to determine the source and clear the corresponding flag.
- Both USART's are identical, except for the additional interrupt controls in the Bit 4 of the additional interrupt control registers (A7h, B7h)

Figure 15. Interrupt system

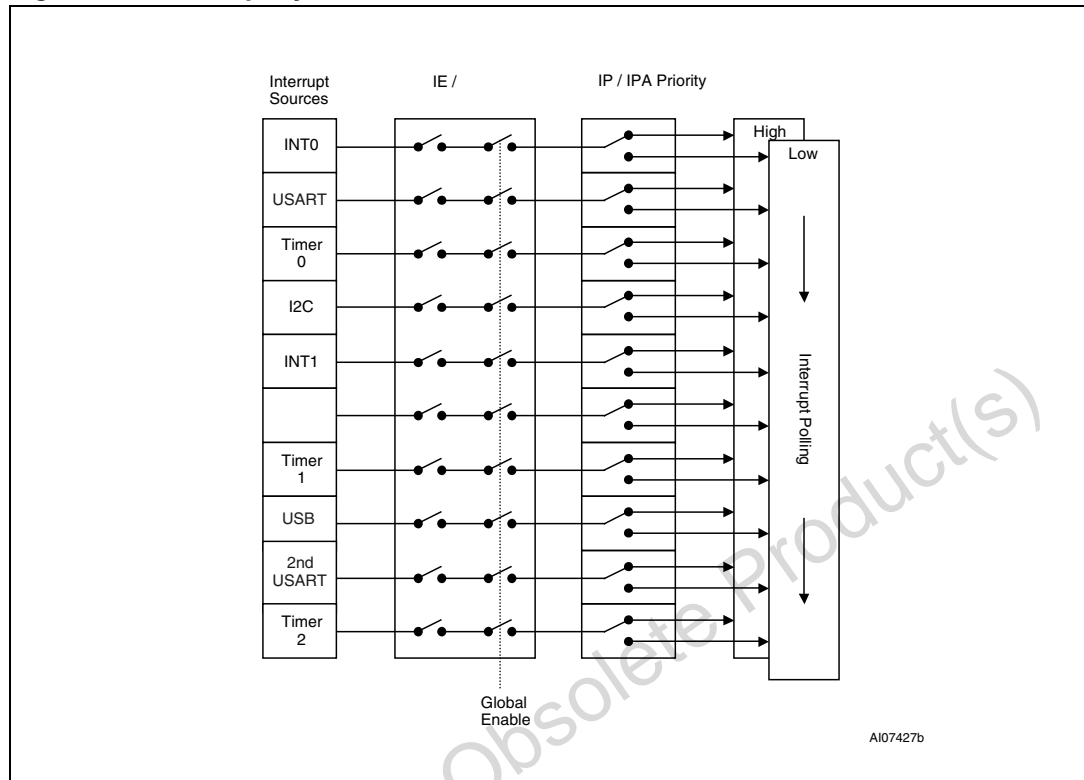

Table 18. SFR register description

SFR Addr	Reg Name	Bit Register Name								Reset Value	Comments
		7	6	5	4	3	2	1	0		
A7	IEA	—	—	—	ES2	—	—	EI <sup>2</sup> C	EUSB	00	Interrupt Enable (2nd)
A8	IE	EA	—	ET2	ES	ET1	EX1	ET0	EX0	00	Interrupt Enable
B7	IPA	—	—	—	PS2	—	—	PI <sup>2</sup> C	PUSB	00	Interrupt Priority (2nd)
B8	IP	—	—	PT2	PS	PT1	PX1	PT0	PX0	00	Interrupt Priority

### 5.8 Interrupt priority structure

Each interrupt source can be assigned one of two priority levels. Interrupt priority levels are defined by the interrupt priority special function register IP and IPA.

- 0 = low priority
- 1 = high priority

A low priority interrupt may be interrupted by a high priority interrupt level interrupt. A high priority interrupt routine cannot be interrupted by any other interrupt source. If two interrupts of different priority occur simultaneously, the high priority level request is serviced. If requests of the same priority are received simultaneously, an internal polling sequence determines which request is serviced. Thus, within each priority level, there is a second priority structure determined by the polling sequence.

## 5.9 Interrupt enable structure

Each interrupt source can be individually enabled or disabled by setting or clearing a bit in the interrupt enable special function registers IE and IEA. All interrupt sources can also be globally disabled by clearing Bit EA in register IE.

**Table 19. Priority levels**

Source	Priority with Level
Int0	0 (highest)
2nd USART	1
Timer 0	2
I <sup>2</sup> C	3
Int1	4
Reserved	5
Timer 1	6
USB	7
1st USART	8
Timer 2+EXF2	9 (lowest)

**Table 20. Description of the IE bits**

Bit	Symbol	Function
7	EA	Disable all interrupts: 0: no interrupt will be acknowledged 1: each interrupt source is individually enabled or disabled by setting or clearing its enable bit
6	—	Reserved
5	ET2	Enable Timer 2 Interrupt
4	ES	Enable USART Interrupt
3	ET1	Enable Timer 1 Interrupt
2	EX1	Enable External Interrupt (Int1)
1	ET0	Enable Timer 0 Interrupt
0	EX0	Enable External Interrupt (Int0)

**Table 21. Description of the IEA bits**

Bit	Symbol	Function
7	—	Not used
6	—	Not used
5	—	Not used
4	ES2	Enable 2nd USART Interrupt
3	—	Not used
2	—	Not used
1	EI2C	Enable I <sup>2</sup> C Interrupt
0	EUSB	Enable USB Interrupt

**Table 22. Description of the IP bits**

Bit	Symbol	Function
7	—	Reserved
6	—	Reserved
5	PT2	Timer 2 Interrupt priority level
4	PS	USART Interrupt priority level
3	PT1	Timer 1 Interrupt priority level
2	PX1	External Interrupt (Int1) priority level
1	PT0	Timer 0 Interrupt priority level
0	PX0	External Interrupt (Int0) priority level

**Table 23. Description of the IPA bits**

Bit	Symbol	Function
7	—	Not used
6	—	Not used
5	—	Not used
4	PS2	2nd USART Interrupt priority level
3	—	Not used
2	—	Not used
1	PI2C	I <sup>2</sup> C Interrupt priority level
0	PUSB	USB Interrupt priority level

### 5.10 How interrupts are handled

The interrupt flags are sampled at S5P2 of every machine cycle. The samples are polled during following machine cycle. If one of the flags was in a set condition at S5P2 of the preceding cycle, the polling cycle will find it and the interrupt system will generate an LCALL to the appropriate service routine, provided this H/W generated LCALL is not blocked by any of the following conditions:

- An interrupt of equal priority or higher priority level is already in progress.
- The current machine cycle is not the final cycle in the execution of the instruction in progress.
- The instruction in progress is RETI or any access to the interrupt priority or interrupt enable registers.

The polling cycle is repeated with each machine cycle, and the values polled are the values that were present at S5P2 of the previous machine cycle.

*Note: If an interrupt flag is active but being responded to for one of the above mentioned conditions, if the flag is still inactive when the blocking condition is removed, the denied interrupt will not be serviced. In other words, the fact that the interrupt flag was once active but not serviced is not remembered. Every polling cycle is new.*

The processor acknowledges an interrupt request by executing a hardware generated LCALL to the appropriate service routine. The hardware generated LCALL pushes the contents of the Program Counter on to the stack (but it does not save the PSW) and reloads the PC with an address that depends on the source of the interrupt being vectored to as shown in [Table 24](#).

Execution proceeds from that location until the RETI instruction is encountered. The RETI instruction informs the processor that the interrupt routine is no longer in progress, then pops the top two bytes from the stack and reloads the Program Counter. Execution of the interrupted program continues from where it left off.

*Note: A simple RET instruction would also return execution to the interrupted program, but it would have left the interrupt control system thinking an interrupt was still in progress, making future interrupts impossible.*

**Table 24. Vector addresses**

Source	Vector address
Int0	0003h
2nd USART	004Bh
Timer 0	000Bh
I <sup>2</sup> C	0043h
Int1	0013h
Timer 1	001Bh
USB	0033h
1st USART	0023h
Timer 2+EXF2	002Bh

## 6 Power-saving mode

Two software selectable modes of reduced power consumption are implemented.

### 6.1 Idle mode

In Idle mode, the following functions are switched Off.

- CPU (Halted)

The following functions remain Active during Idle mode:

- External Interrupts
- Timer 0, Timer 1, Timer 2
- PWM Units
- USB Interface
- USART
- 8-bit ADC
- I<sup>2</sup>C Interface

*Note:* Interrupt or  $\overline{RESET}$  terminates the Idle mode.

### 6.2 Power-down mode

- System Clock Halted
- LVD Logic Remains Active
- SRAM content remains unchanged
- The SFRs retain their value until a  $\overline{RESET}$  is asserted

*Note:* The only way to exit Power-down mode is through a  $\overline{RESET}$ .

**Table 25. Power-saving mode power consumption**

Mode	Addr/data	Ports 1,3,4	PWM	I <sup>2</sup> C	USB
Idle	Maintain Data	Maintain Data	Active	Active	Active
Power-down	Maintain Data	Maintain Data	Disable	Disable	Disable

### 6.3 Power control register

The Idle and Power-down modes are activated by software via the PCON register.

**Table 26. Pin status during Idle and Power-down mode**

SFR Addr	Reg Name	Bit Register Name								Reset Value	Comments
		7	6	5	4	3	2	1	0		
87	PCON	SMOD	SMOD1	LVREN	ADSFINT	RCLK1	TCLK1	PD	IDLE	00	Power Ctrl



**Table 27. Description of the PCON bits**

Bit	Symbol	Function
7	SMOD	Double baud data rate bit UART
6	SMOD1	Double baud data rate bit 2nd UART
5	LVREN	LVR disable bit (active High)
4	ADSFINT	Enable ADC Interrupt
3	RCLK1 <sup>(1)</sup>	Received clock flag (UART 2)
2	TCLK1 <sup>(1)</sup>	Transmit clock flag (UART 2)
1	PD	Activate Power-down mode (High enable)
0	IDL	Activate Idle mode (High enable)

1. See the T2CON register for details of the flag description

## 6.4 Idle mode

The instruction that sets PCON.0 is the last instruction executed in the normal operating mode before Idle mode is activated. Once in the Idle mode, the CPU status is preserved in its entirety: Stack pointer, Program counter, Program status word, Accumulator, RAM and All other registers maintain their data during Idle mode.

There are three ways to terminate the Idle mode.

1. Activation of any enabled interrupt will cause PCON.0 to be cleared by hardware terminating Idle mode. The interrupt is serviced, and following return from interrupt instruction RETI, the next instruction to be executed will be the one which follows the instruction that wrote a logic '1' to PCON.0.
2. External hardware reset: the hardware reset is required to be active for two machine cycle to complete the RESET operation.
3. Internal reset: the microcontroller restarts after 3 machine cycles in all cases.

## 6.5 Power-down mode

The instruction that sets PCON.1 is the last executed prior to going into the Power-down mode. Once in Power-down mode, the oscillator is stopped. The contents of the on-chip RAM and the Special Function Register are preserved.

The Power-down mode can be terminated by an external RESET.

## 7 I/O ports (MCU module)

The MCU module has five ports: Port 0, Port 1, Port 2, Port 3, and Port 4. (Refer to the PSD module section on I/O ports A,B,C and D). Ports P0 and P2 are dedicated for the external address and data bus and is not available in the 52-pin package devices.

Port 1- Port 3 are the same as in the standard 8032 microcontrollers, with the exception of the additional special peripheral functions. All ports are bi-directional. Pins of which the alternative function is not used may be used as normal bi-directional I/O.

The use of Port 1-Port 4 pins as alternative functions are carried out automatically by the UPSD321xx devices provided the associated SFR Bit is set HIGH.

The following SFR registers ([Table 29](#), [Table 30](#), and [Table 31](#)) are used to control the mapping of alternate functions onto the I/O port bits. Port 1 alternate functions are controlled using the P1SFS register, except for Timer 2 and the 2nd UART which are enabled by their configuration registers. P1.0 to P1.3 are default to GPIO after reset.

Port 3 pins 6 and 7 have been modified from the standard 8032. These pins that were used for READ and WRITE control signals are now GPIO or I<sup>2</sup>C bus pins. The READ and WRITE pins are assigned to dedicated pins.

Port 3 (I<sup>2</sup>C) and Port 4 alternate functions are controlled using the P3SFS and P4SFS Special Function Selection registers. After a reset, the I/O pins default to GPIO. The alternate function is enabled if the corresponding bit in the PXSFS register is set to '1.' Other Port 3 alternative functions (UART, Interrupt, and Timer/Counter) are enabled by their configuration register and do not require setting of the bits in P3SFS.

**Table 28. I/O port functions**

Port name	Main function	Alternate
Port 1	GPIO	Timer 2 - Bits 0,1 2nd UART - Bits 2,3 ADC - Bits 4..7
Port 3	GPIO	UART - Bits 0,1 Interrupt - Bits 2,3 Timers - Bits 4,5 I <sup>2</sup> C - Bits 6,7
Port 4	GPIO	PWM - Bits 3..7
USB +/-	USB +/- Only	

**Table 29. P1SFS (91h)**

7	6	5	4	3	2	1	0
0=Port 1.7 1=ACH3	0=Port 1.6 1=ACH2	0=Port 1.5 1=ACH1	0=Port 1.4 1=ACH0	Bits are reserved		Bits are reserved	

**Table 30. P3SFS (93h)**

7	6	5	4	3	2	1	0
0 = Port 3.7 1 = SCL from I <sup>2</sup> C unit	0 = Port 3.6 1 = SDA from I <sup>2</sup> C unit	Bits are reserved					

**Table 31. P4SFS (94h)**

7	6	5	4	3	2	1	0
0=Port 4.7 1=PWM 4	0=Port 4.6 1=PWM 3	0=Port 4.5 1=PWM 2	0=Port 4.4 1=PWM 1	0=Port 4.3 1=PWM 0	0=Port 4.2 1=V <sub>SYNC</sub>	0=Port 4.1 1=DDC - SCL	0=Port 4.0 1=DDC - SDA

## 7.1 Port type and description

**Figure 16. Port type and description (Part 1)**

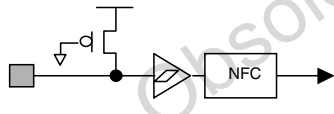
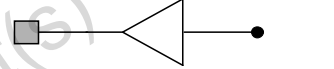
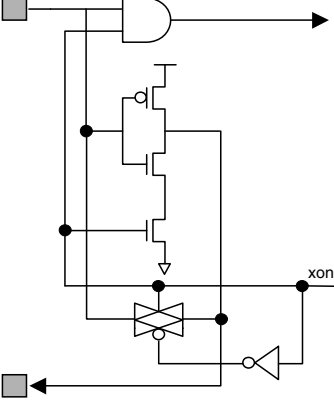
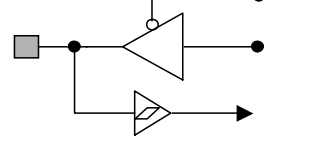
Symbol	In / Out	Circuit	Description
RESET	I		<ul style="list-style-type: none"> <li>Schmitt input with internal pull-up</li> <li>CMOS compatible interface</li> <li>NFC : 400ns</li> </ul>
WR, RD,ALE, PSEN	O		Output only
XTAL1, XTAL2	I  O		<ul style="list-style-type: none"> <li>On-chip oscillator</li> <li>On-chip feedback resistor</li> <li>Stop in the power down mode</li> <li>External clock input available</li> <li>CMOS compatible interface</li> </ul>
PORT0	I/O		<ul style="list-style-type: none"> <li>Bidirectional I/O port</li> <li>Schmitt input</li> <li>Address Output ( Push-Pull )</li> <li>CMOS compatible interface</li> </ul>

A106653

Figure 17. Port type and description (Part 2)

	In/ Out		Function
PORT1 <3:0>, PORT3, PORT4<7:3,1:0>  PORT2	I/O		Bidirectional I/O port with internal pull-ups Schmitt input CMOS compatible interface
PORT1 < 7:4 >	I/O		Bidirectional I/O port with internal pull-ups Schmitt input CMOS compatible interface Analog input option
PORT4.2	I/O		Bidirectional I/O port with internal pull-ups Schmitt input. TTL compatible interface
USB-, USB+	I/O		Bidirectional I/O port Schmitt input TTL compatible interface

A107428b

## 8 Oscillator

The oscillator circuit of the UPSD321xx devices is a single stage inverting amplifier in a Pierce oscillator configuration. The circuitry between XTAL1 and XTAL2 is basically an inverter biased to the transfer point. Either a crystal or ceramic resonator can be used as the feedback element to complete the oscillator circuit. Both are operated in parallel resonance.

XTAL1 is the high gain amplifier input, and XTAL2 is the output. To drive the UPSD321xx devices externally, XTAL1 is driven from an external source and XTAL2 left open-circuit.

**Figure 18. Oscillator**

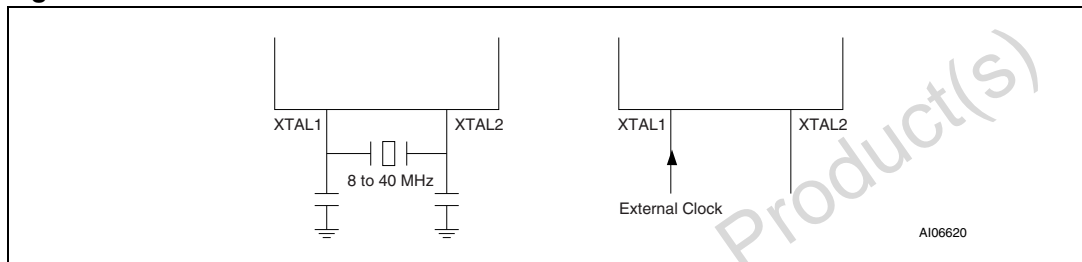

## 9 Supervisory

There are four ways to invoke a reset and initialize the UPSD321xx devices.

1. Via the external  $\overline{\text{RESET}}$  pin
2. Via the internal LVR block
3. Via USB bus reset signaling
4. Via Watchdog Timer (WDT)

The  $\overline{\text{RESET}}$  mechanism is illustrated in [Figure 19](#).

Each  $\overline{\text{RESET}}$  source will cause an internal reset signal active. The CPU responds by executing an internal reset and puts the internal registers in a defined state. This internal reset is also routed as an active low reset input to the PSD module.

**Figure 19.  $\overline{\text{RESET}}$  configuration**

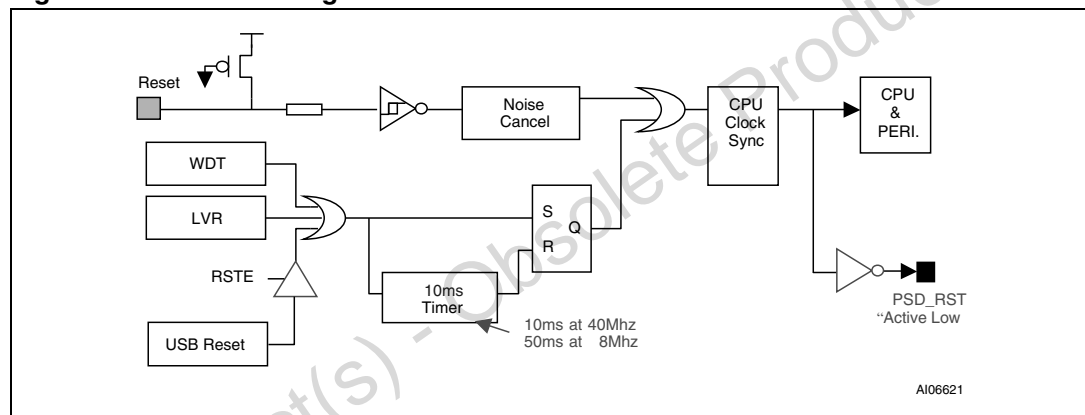

### 9.1 External reset

The  $\overline{\text{RESET}}$  pin is connected to a Schmitt trigger for noise reduction. A  $\overline{\text{RESET}}$  is accomplished by holding the  $\overline{\text{RESET}}$  pin LOW for at least 1ms at power up while the oscillator is running. Refer to AC spec on other  $\overline{\text{RESET}}$  timing requirements.

### 9.2 Low $V_{DD}$ voltage reset

An internal reset is generated by the LVR circuit when the  $V_{DD}$  drops below the reset threshold. After  $V_{DD}$  reaching back up to the reset threshold, the  $\overline{\text{RESET}}$  signal will remain asserted for 10ms before it is released. On initial power-up the LVR is enabled (default). After power-up the LVR can be disabled via the LVREN Bit in the PCON Register.

*Note: The LVR logic is still functional in both the Idle and Power-down modes.*

The reset threshold:

- 5 V operation:  $4 \text{ V} \pm 0.25 \text{ V}$
- 3.3 V operation:  $2.5 \text{ V} \pm 0.2 \text{ V}$

This logic supports approximately 0.1 V of hysteresis and 1  $\mu\text{s}$  noise-cancelling delay.

### 9.3 Watchdog timer overflow

The Watchdog timer generates an internal reset when its 22-bit counter overflows. See Watchdog Timer section for details.

### 9.4 USB reset

The USB reset is generated by a detection on the USB bus  $\overline{\text{RESET}}$  signal. A single-end zero on its upstream port for 4 to 8 times will set RSTF Bit in UISTA register. If Bit 6 (RSTE) of the UIEN Register is set, the detection will also generate the  $\overline{\text{RESET}}$  signal to reset the CPU and other peripherals in the MCU.

Obsolete Product(s) - Obsolete Product(s)

## 10 Watchdog timer

The hardware watchdog timer (WDT) resets the UPSD321xx devices when it overflows. The WDT is intended as a recovery method in situations where the CPU may be subjected to a software upset. To prevent a system reset the timer must be reloaded in time by the application software. If the processor suffers a hardware/software malfunction, the software will fail to reload the timer. This failure will result in a reset upon overflow thus preventing the processor running out of control.

In the Idle mode the watchdog timer and reset circuitry remain active. The WDT consists of a 22-bit counter, the Watchdog Timer  $\overline{\text{RESET}}$  (WDRST) SFR and Watchdog Key Register (WDKEY).

Since the WDT is automatically enabled while the processor is running, the user only needs to be concerned with servicing it.

The 22-bit counter overflows when it reaches 4194304 (3FFFFFFH). The WDT increments once every machine cycle.

This means the user must reset the WDT at least every 4194304 machine cycles (1.258 seconds at 40MHz). To reset the WDT the user must write a value between 00-7EH to the WDRST register. The value that is written to the WDRST is loaded to the 7MSB of the 22-bit counter. This allows the user to pre-load the counter to an initial value to generate a flexible Watchdog time out period. Writing a "00" to WDRST clears the counter.

The watchdog timer is controlled by the watchdog key register, WDKEY. Only pattern 01010101 (=55H), disables the watchdog timer. The rest of pattern combinations will keep the watchdog timer enabled. This security key will prevent the watchdog timer from being terminated abnormally when the function of the watchdog timer is needed.

In Idle mode, the oscillator continues to run. To prevent the WDT from resetting the processor while in Idle, the user should always set up a timer that will periodically exit Idle, service the WDT, and re-enter Idle mode.

Watchdog reset pulse width depends on the clock frequency. The reset period is  $t_{\text{OSC}} \times 12 \times 2^{22}$ .

The  $\overline{\text{RESET}}$  pulse width is  $t_{\text{OSC}} \times 12 \times 2^{15}$ .

**Table 32. Watchdog timer key register (WDKEY: 0AEh)**

7	6	5	4	3	2	1	0
WDKEY7	WDKEY6	WDKEY5	WDKEY4	WDKEY3	WDKEY2	WDKEY1	WDKEY0

**Table 33. Description of the WDKEY Bits**

Bit	Symbol	Function
7 to 0	WDKEY7 to WDKEY0	Enable or disable watchdog timer. 01010101 (=55h): disable watchdog timer. Others: enable watchdog timer



Figure 20.  $\overline{\text{RESET}}$  pulse width

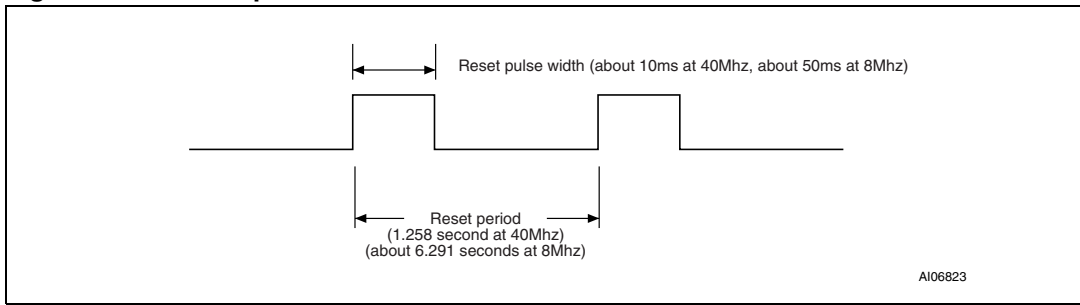

Table 34. Watchdog timer clear register (WDRST: 0A6h)

7	6	5	4	3	2	1	0
Reserved	WDRST6	WDRST5	WDRST4	WDRST3	WDRST2	WDRST1	WDRST0

Table 35. Description of the WDRST Bits

Bit	Symbol	Function
7	—	Reserved
6 to 0	WDRST6 to WDRST0	To reset watchdog timer, write any value between 00h and 7Eh to this register. This value is loaded to the 7 most significant bits of the 22-bit counter. For example: MOV WDRST,#1EH

1. The Watchdog Timer (WDT) is enabled at power-up or reset and must be served or disabled.

# 11 Timer/counters (Timer 0, Timer 1 and Timer 2)

The UPSD321xx devices has three 16-bit Timer/Counter registers: Timer 0, Timer 1 and Timer 2. All of them can be configured to operate either as timers or event counters and are compatible with standard 8032 architecture.

In the “Timer” function, the register is incremented every machine cycle. Thus, one can think of it as counting machine cycles. Since a machine cycle consists of 6 CPU clock periods, the count rate is 1/6 of the CPU clock frequency or 1/12 of the oscillator frequency ( $f_{OSC}$ ).

In the “Counter” function, the register is incremented in response to a 1-to-0 transition at its corresponding external input pin, T0 or T1. In this function, the external input is sampled during S5P2 of every machine cycle. When the samples show a high in one cycle and a low in the next cycle, the count is incremented. The new count value appears in the register during S3P1 of the cycle following the one in which the transition was detected. Since it takes 2 machine cycles ( $24 f_{OSC}$  clock periods) to recognize a 1-to-0 transition, the maximum count rate is 1/24 of the  $f_{OSC}$ . There are no restrictions on the duty cycle of the external input signal, but to ensure that a given level is sampled at least once before it changes, it should be held for at least one full cycle. In addition to the “Timer” or “Counter” selection, Timer 0 and Timer 1 have four operating modes from which to select.

## 11.1 Timer 0 and Timer 1

The “Timer” or “Counter” function is selected by control bits C/ T in the Special Function Register TMOD. These Timer/Counters have four operating modes, which are selected by bit-pairs (M1, M0) in TMOD. Modes 0, 1, and 2 are the same for Timers/ Counters. Mode 3 is different. The four operating modes are de-scribed in the following text.

**Table 36. Control register (TCON)**

7	6	5	4	3	2	1	0
TF1	TR1	TF0	TR0	IE1	IT1	IE0	IT0

**Table 37. Description of the TCON bits**

Bit	Symbol	Function
7	TF1	Timer 1 overflow flag. Set by hardware on Timer/Counter overflow. Cleared by hardware when processor vectors to interrupt routine
6	TR1	Timer 1 run control bit. Set/cleared by software to turn Timer/Counter on or off
5	TF0	Timer 0 overflow flag. Set by hardware on Timer/Counter overflow. Cleared by hardware when processor vectors to interrupt routine
4	TR0	Timer 0 run control bit. Set/cleared by software to turn Timer/Counter on or off
3	IE1	Interrupt 1 Edge Flag. Set by hardware when external interrupt edge detected. Cleared when interrupt processed
2	IT1	Interrupt 1 Type Control Bit. Set/cleared by software to specify falling-edge/low-level triggered external interrupt

**Table 37. Description of the TCON bits**

Bit	Symbol	Function
1	IE0	Interrupt 0 Edge Flag. Set by hardware when external interrupt edge detected. Cleared when interrupt processed
0	IT0	Interrupt 0 Type Control Bit. Set/cleared by software to specify falling-edge/low-level triggered external interrupt

### 11.1.1 Mode 0

Putting either Timer into Mode 0 makes it look like an 8048 Timer, which is an 8-bit Counter with a divide-by-32 prescaler. *Figure 21* shows the Mode 0 operation as it applies to Timer 1.

In this mode, the Timer register is configured as a 13-bit register. As the count rolls over from all '1s' to all '0s,' it sets the Timer Interrupt Flag TF1. The counted input is enabled to the Timer when TR1 = 1 and either GATE = 0 or /INT1 = 1. (Setting GATE = 1 allows the Timer to be controlled by external input /INT1, to facilitate pulse width measurements). TR1 is a control bit in the Special Function Register TCON (TCON Control Register). GATE is in TMOD.

The 13-bit register consists of all 8 bits of TH1 and the lower 5 bits of TL1. The upper 3 bits of TL1 are indeterminate and should be ignored. Setting the run flag does not clear the registers.

Mode 0 operation is the same for the Timer 0 as for Timer 1. Substitute TR0, TF0, and /INT0 for the corresponding Timer 1 signals in *Figure 21* There are two different GATE Bits, one for Timer 1 and one for Timer0.

**Figure 21. Timer/counter mode 0: 13-bit counter**

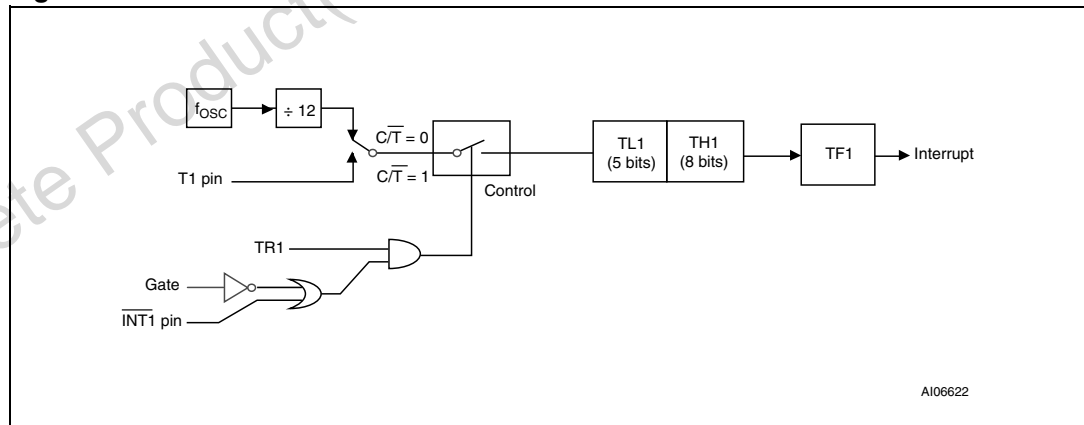

### 11.1.2 Mode 1

Mode 1 is the same as Mode 0, except that the Timer register is being run with all 16 bits.

**Table 38. TMOD register (TMOD)**

7	6	5	4	3	2	1	0
Gate	C/T-bar	M1	M0	Gate	C/T-bar	M1	M0

**Table 39. Description of the TMOD bits**

Bit	Symbol	Timer	Function
7	Gate	Timer1	Gating control when set. Timer/Counter 1 is enabled only while INT1 pin is High and TR1 control pin is set. When cleared, Timer 1 is enabled whenever TR1 control bit is set
6	C/T		Timer or Counter selector, cleared for timer operation (input from internal system clock); set for counter operation (input from T1 input pin)
5	M1		(M1,M0)=(0,0): 13-bit Timer/Counter, TH1, with TL1 as 5-bit prescaler (M1,M0)=(0,1): 16-bit Timer/Counter. TH1 and TL1 are cascaded. There is no prescaler.
4	M0		(M1,M0)=(1,0): 8-bit auto-reload Timer/Counter. TH1 holds a value which is to be reloaded into TL1 each time it overflows (M1,M0)=(1,1): Timer/Counter 1 stopped
3	Gate	Timer0	Gating control when set. Timer/Counter 0 is enabled only while INT0 pin is High and TR0 control pin is set. When cleared, Timer 0 is enabled whenever TR0 control bit is set
2	C/T		Timer or Counter selector, cleared for timer operation (input from internal system clock); set for counter operation (input from T0 input pin)
1	M1		(M1,M0)=(0,0): 13-bit Timer/Counter, TH0, with TL0 as 5-bit prescaler (M1,M0)=(0,1): 16-bit Timer/Counter. TH0 and TL0 are cascaded. There is no prescaler.
0	M0		(M1,M0)=(1,0): 8-bit auto-reload Timer/Counter. TH0 holds a value which is to be reloaded into TL0 each time it overflows (M1,M0)=(1,1): TL0 is an 8-bit Timer/Counter controlled by the standard Timer 0 control bits. TH0 is an 8-bit timer only controlled by Timer 1 control bits

**11.1.3 Mode 2**

Mode 2 configures the Timer register as an 8-bit Counter (TL1) with automatic reload, as shown in *Figure 22*. Overflow from TL1 not only sets TF1, but also reloads TL1 with the contents of TH1, which is preset by software. The reload leaves TH1 unchanged. Mode 2 operation is the same for Timer/Counter 0.

**Figure 22. Timer/counter mode 2: 8-bit Auto-reload**

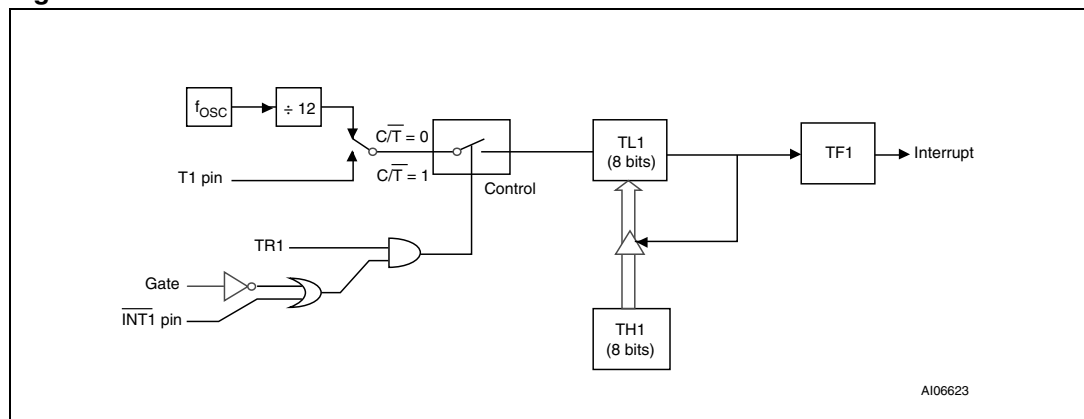

### 11.1.4 Mode 3

Timer 1 in Mode 3 simply holds its count. The effect is the same as setting  $TR1 = 0$ .

Timer 0 in Mode 3 establishes TL0 and TH0 as two separate counters. The logic for Mode 3 on Timer 0 is shown in [Figure 23](#). TL0 uses the Timer 0 control Bits: C/T, GATE, TR0, INT0, and TF0. TH0 is locked into a timer function (counting machine cycles) and takes over the use of TR1 and TF1 from Timer 1. Thus, TH0 now controls the “Timer 1” Interrupt.

Mode 3 is provided for applications requiring an extra 8-bit timer on the counter. With Timer 0 in Mode 3, an UPSD321xx devices can look like it has three Timer/Counters. When Timer 0 is in Mode 3, Timer 1 can be turned on and off by switching it out of and into its own Mode 3, or can still be used by the serial port as a baud rate generator, or in fact, in any application not requiring an interrupt.

**Figure 23. Timer/counter mode 3: two 8-bit counters**

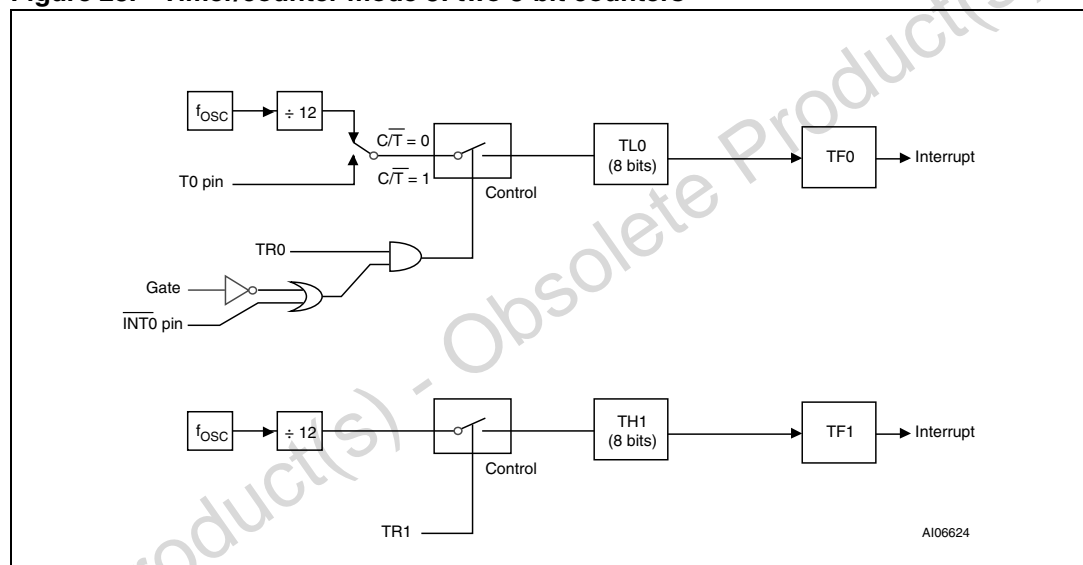

## 11.2 Timer 2

Like Timers 0 and 1, Timer 2 can operate as either an event timer or as an event counter. This is selected by Bit C/T2 in the special function register T2CON. It has three operating modes: Capture, Auto-reload, and Baud Rate Generator, which are selected by bits in the T2CON as shown in [Table 41](#). In the Capture mode there are two options which are selected by Bit EXEN2 in T2CON. If  $EXEN2 = 0$ , then Timer 2 is a 16-bit timer or counter which upon overflowing sets Bit TF2, the Timer 2 Overflow bit, which can be used to generate an interrupt. If  $EXEN2 = 1$ , then Timer 2 still does the above, but with the added feature that a 1-to-0 transition at external input T2EX causes the current value in the Timer 2 registers, TL2 and TH2, to be captured into registers RCAP2L and RCAP2H, respectively. In addition, the transition at T2EX causes Bit EXF2 in T2CON to be set, and EXF2 like TF2 can generate an interrupt. The Capture mode is illustrated in [Figure 24](#).

In the Auto-reload mode, there are again two options, which are selected by bit EXEN2 in T2CON. If  $EXEN2 = 0$ , then when Timer 2 rolls over it not only sets TF2 but also causes the Timer 2 registers to be reloaded with the 16-bit value in registers RCAP2L and RCAP2H, which are preset by software. If  $EXEN2 = 1$ , then Timer 2 still does the above, but with the added feature that a 1-to-0 transition at external input T2EX will also trigger the 16-bit reload

and set EXF2. Auto-reload mode is illustrated in the Standard Serial Interface (UART) *Figure 25*. The Baud Rate Generation mode is selected by (RCLK, RCLK1)=1 and/or (TCLK, TCLK1)=1. It is described in conjunction with the serial port.

**Table 40. Timer/counter 2 control register (T2CON)**

7	6	5	4	3	2	1	0
TF2	EXF2	RCLK	TCLK	EXEN2	TR2	C/ $\bar{T}$ 2	CP/ $\bar{R}$ L2

**Table 41. Description of the T2CON bits**

Bit	Symbol	Function
7	TF2	Timer 2 overflow flag. Set by a Timer 2 overflow, and must be cleared by software. TF2 will not be set when either (RCLK, RCLK1)=1 or (TCLK, TCLK1)=1
6	EXF2	Timer 2 external flag set when either a capture or reload is caused by a negative transition on T2EX and EXEN2=1. When Timer 2 Interrupt is enabled, EXF2=1 will cause the CPU to vector to the Timer 2 Interrupt routine. EXF2 must be cleared by software
5	RCLK <sup>(1)</sup>	Receive clock flag (UART 1). When set, causes the serial port to use Timer 2 overflow pulses for its receive clock in Modes 1 and 3. TCLK=0 causes Timer 1 overflow to be used for the receive clock
4	TCLK <sup>(1)</sup>	Transmit clock flag (UART 1). When set, causes the serial port to use Timer 2 overflow pulses for its transmit clock in Modes 1 and 3. TCLK=0 causes Timer 1 overflow to be used for the transmit clock
3	EXEN2	Timer 2 external enable flag. When set, allows a capture or reload to occur as a result of a negative transition on T2EX if Timer 2 is not being used to clock the serial port. EXEN2=0 causes Time 2 to ignore events at T2EX
2	TR2	Start/stop control for Timer 2. A logic 1 starts the timer
1	C/ $\bar{T}$ 2	Timer or Counter select for Timer 2. Cleared for timer operation (input from internal system clock, $t_{CPU}$ ); set for external event counter operation (negative edge triggered)
0	CP/ $\bar{R}$ L2	Capture/reload flag. When set, capture will occur on negative transition of T2EX if EXEN2=1. When cleared, auto-reload will occur either with Timer 2 overflows, or negative transitions of T2EX when EXEN2=1. When either (RCLK, RCLK1)=1 or (TCLK, TCLK1)=1, this bit is ignored, and timer is forced to auto-reload on Timer 2 overflow

1. The RCLK1 and TCLK1 Bits in the PCON Register control UART 2, and have the same function as RCLK and TCLK.

Table 42. Timer/counter2 operating modes

Mode	T2CON			T2MOD DECN	T2CON EXEN	P1.1 T2EX	Remarks	Input clock	
	RxCLK or TxCLK	CP/ $\bar{R}$ L2	TR2					Internal	External (P1.0/T2)
16-bit Auto- reload	0	0	1	0	0	x	Reload upon overflow	$f_{osc}/12$	MAX $f_{osc}/24$
	0	0	1	0	1	-	Reload trigger (falling edge)		
	0	0	1	1	x	0	Down counting		
	0	0	1	1	x	1	Up counting		
16-bit Capture	0	1	1	x	0	x	16-bit Timer/Counter (only up counting)	$f_{osc}/12$	MAX $f_{osc}/24$
	0	1	1	x	1	-	Capture (TH1,TL2) → (RCAP2H,RCAP2L)		
Baud Rate Generator	1	x	1	x	0	x	No overflow interrupt request (TF2)	$f_{osc}/12$	MAX $f_{osc}/24$
	1	x	1	x	1	-	Extra External Interrupt (Timer 2)		
Off	x	x	0	x	x	x	Timer 2 stops	—	—

1. ↓ = falling edge

Figure 24. Timer 2 in Capture mode

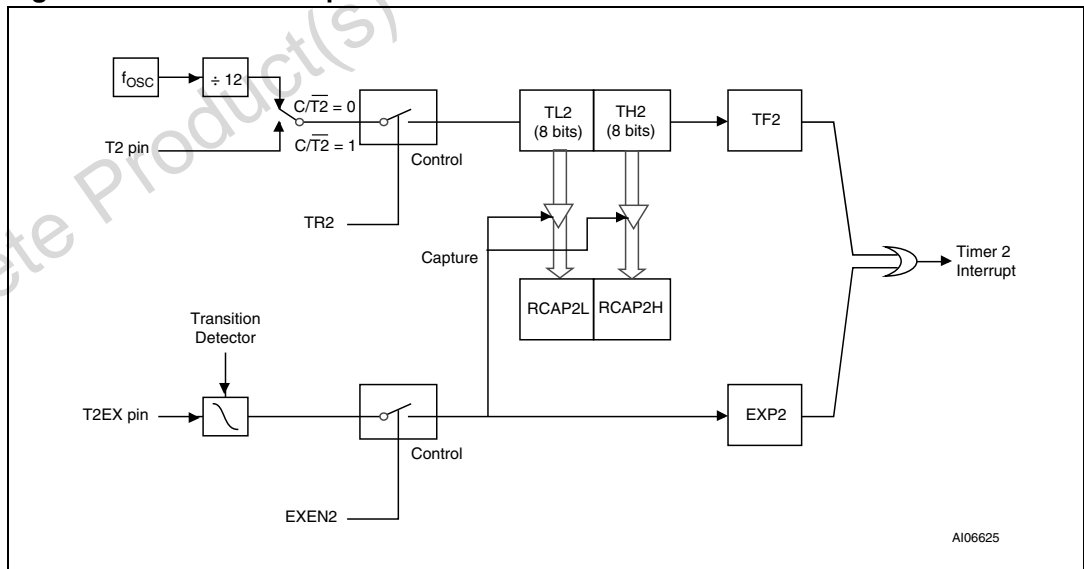
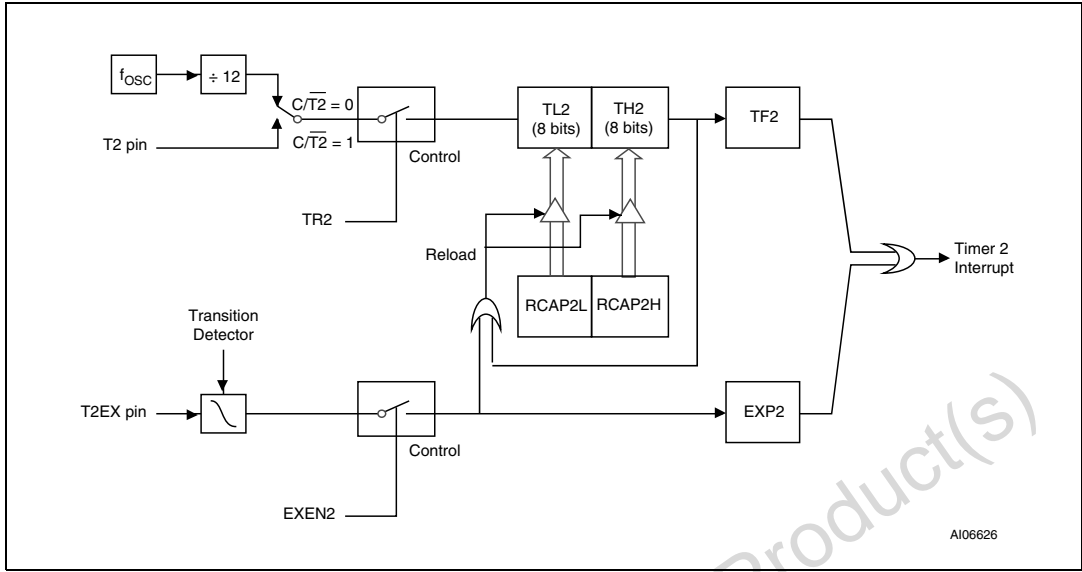

Figure 25. Timer 2 in Auto-Reload mode



Obsolete Product(s) - Obsolete Product(s)



## 12 Standard serial interface (UART)

The UPSD321xx devices provides two standard 8032 UART serial ports. The first port is connected to pin P3.0 (RX) and P3.1 (TX). The second port is connected to pin P1.2 (RX) and P1.3(TX). The operation of the two serial ports are the same and are controlled by the SCON and SCON2 registers.

The serial port is full duplex, meaning it can transmit and receive simultaneously. It is also receive-buffered, meaning it can commence reception of a second byte before a previously received byte has been read from the register. (However, if the first byte still has not been read by the time reception of the second byte is complete, one of the bytes will be lost.) The serial port receive and transmit registers are both accessed at Special Function Register SBUF (or SBUF2 for the second serial port). Writing to SBUF loads the transmit register, and reading SBUF accesses a physically separate receive register.

The serial port can operate in 4 modes: Mode 0, 1, 2 or 3.

### Mode 0

Serial data enters and exits through RxD. TxD outputs the shift clock. 8 bits are transmitted/received (LSB first). The baud rate is fixed at  $1/12$  the  $f_{OSC}$ .

### Mode 1

10 bits are transmitted (through TxD) or received (through RxD): a Start bit (0), 8 data bits (LSB first), and a Stop bit (1). On receive, the Stop bit goes into RB8 in Special Function Register SCON. The baud rate is variable.

### Mode 2

11 bits are transmitted (through TxD) or received (through RxD): Start bit (0), 8 data bits (LSB first), a programmable 9th data bit, and a Stop bit (1). On Transmit, the 9th data bit (TB8 in SCON) can be assigned the value of '0' or '1'. Or, for example, the Parity bit (P, in the PSW) could be moved into TB8. On receive, the 9th data bit goes into RB8 in Special Function Register SCON, while the Stop bit is ignored. The baud rate is programmable to either  $1/32$  or  $1/64$  the oscillator frequency.

### Mode 3

11 bits are transmitted (through TxD) or received (through RxD): a Start bit (0), 8 data bits (LSB first), a programmable 9th data bit, and a Stop bit (1). In fact, Mode 3 is the same as Mode 2 in all respects except baud rate. The baud rate in Mode 3 is variable.

In all four modes, transmission is initiated by any instruction that uses SBUF as a destination register. Reception is initiated in Mode 0 by the condition  $RI = 0$  and  $REN = 1$ . Reception is initiated in the other modes by the incoming start bit if  $REN = 1$ .

### 12.1 Multiprocessor communications

Modes 2 and 3 have a special provision for multiprocessor communications. In these modes, 9 data bits are received. The 9th one goes into RB8. Then comes a Stop bit. The port can be programmed such that when the Stop bit is received, the serial port interrupt will

be activated only if RB8 = 1. This feature is enabled by setting Bit SM2 in SCON. A way to use this feature in multi-processor systems is as follows:

When the master processor wants to transmit a block of data to one of several slaves, it first sends out an address byte which identifies the target slave. An address byte differs from a data byte in that the 9th bit is '1' in an address byte and 0 in a data byte. With SM2 = 1, no slave will be interrupted by a data byte. An address byte, however, will interrupt all slaves, so that each slave can examine the received byte and see if it is being addressed. The addressed slave will clear its SM2 bit and prepare to receive the data bytes that will be coming. The slaves that weren't being addressed leave their SM2s set and go on about their business, ignoring the coming data bytes.

SM2 has no effect in Mode 0, and in Mode 1 can be used to check the validity of the Stop bit. In a Mode 1 reception, if SM2 = 1, the receive interrupt will not be activated unless a valid Stop bit is received.

## 12.2 Serial port control register

The serial port control and status register is the Special Function Register SCON (SCON2 for the second port), shown in *Figure 26*. This register contains not only the mode selection bits, but also the 9th data bit for transmit and receive (TB8 and RB8), and the Serial Port Interrupt bits (TI and RI).

**Table 43. Serial port control register (SCON)**

7	6	5	4	3	2	1	0
SM0	SM1	SM2	REN	TB8	RB8	TI	RI

**Table 44. Description of the SCON bits**

Bit	Symbol	Function
7	SM0	(SM1,SM0)=(0,0): Shift Register. Baud rate = $f_{OSC}/12$
6	SM1	(SM1,SM0)=(1,0): 8-bit UART. Baud rate = variable
		(SM1,SM0)=(0,1): 8-bit UART. Baud rate = $f_{OSC}/64$ or $f_{OSC}/32$
		(SM1,SM0)=(1,1): 8-bit UART. Baud rate = variable
5	SM2	Enables the multiprocessor communication features in Mode 2 and 3. In Mode 2 or 3, if SM2 is set to '1,' RI will not be activated if its received 8th data bit (RB8) is '0.' In Mode 1, if SM2=1, RI will not be activated if a valid Stop bit was not received. In Mode 0, SM2 should be '0'
4	REN	Enables serial reception. Set by software to enable reception. Clear by software to disable reception
3	TB8	The 8th data bit that will be transmitted in Modes 2 and 3. Set or clear by software as desired
2	RB8	In Modes 2 and 3, this bit contains the 8th data bit that was received. In Mode 1, if SM2=0, RB8 is the Snap Bit that was received. In Mode 0, RB8 is not used

**Table 44. Description of the SCON bits (continued)**

Bit	Symbol	Function
1	TI	Transmit Interrupt Flag. Set by hardware at the end of the 8th bit time in Mode 0, or at the beginning of the Stop bit in the other modes, in any serial transmission. Must be cleared by software
0	RI	Receive Interrupt Flag. Set by hardware at the end of the 8th bit time in Mode 0, or halfway through the Stop bit in the other modes, in any serial reception (except for SM2). Must be cleared by software

### 12.2.1 Baud rates

The baud rate in Mode 0 is fixed:

$$\text{Mode 0 Baud Rate} = f_{\text{OSC}} / 12$$

The baud rate in Mode 2 depends on the value of Bit SMOD = 0 (which is the value on reset), the baud rate is 1/64 the oscillator frequency. If SMOD = 1, the baud rate is 1/32 the oscillator frequency.

$$\text{Mode 2 Baud Rate} = (2^{\text{SMOD}} / 64) \times f_{\text{OSC}}$$

In the UPSD321xx devices, the baud rates in Modes 1 and 3 are determined by the Timer 1 overflow rate.

### 12.2.2 Using Timer 1 to generate baud rates

When Timer 1 is used as the baud rate generator, the baud rates in Modes 1 and 3 are determined by the Timer 1 overflow rate and the value of SMOD as follows:

$$\text{Modes 1 and 3 Baud Rate} = (2^{\text{SMOD}} / 32) \times (\text{Timer 1 overflow rate})$$

The Timer 1 Interrupt should be disabled in this application. The Timer itself can be configured for either “timer” or “counter” operation, and in any of its 3 running modes. In the most typical applications, it is configured for “timer” operation, in the Auto-reload mode (high nibble of TMOD = 0010B). In that case the baud rate is given by the formula:

$$\text{Modes 1 and 3 Baud Rate} = (2^{\text{SMOD}} / 32) \times (f_{\text{OSC}} / (12 \times [256 - (\text{TH1})]))$$

One can achieve very low baud rates with Timer 1 by leaving the Timer 1 Interrupt enabled, and configuring the Timer to run as a 16-bit timer (high nibble of TMOD = 0001B), and using the Timer 1 Interrupt to do a 16-bit software reload. [Figure 21](#) lists various commonly used baud rates and how they can be obtained from Timer 1.

### 12.2.3 Using Timer/counter 2 to generate baud rates

In the UPSD321xx devices, Timer 2 selected as the baud rate generator by setting TCLK and/or RCLK (see [Figure 21](#) Timer/ Counter 2 Control Register (T2CON)).

*Note:* The baud rate for transmit and receive can be simultaneously different. Setting RCLK and/or TCLK puts Timer into its Baud Rate Generator mode.

The RCLK and TCLK Bits in the T2CON register configure UART 1. The RCLK1 and TCLK1 Bits in the PCON register configure UART 2.

The Baud Rate Generator mode is similar to the Auto-reload Mmode, in that a roll over in TH2 causes the Timer 2 registers to be reloaded with the 16-bit value in registers RCAP2H and RCAP2L, which are preset by software.

Now, the baud rates in Modes 1 and 3 are determined at Timer 2's overflow rate as follows:

$$\text{Modes 1 and 3 Baud Rate} = \text{Timer 2 Overflow Rate} / 16$$

**Table 45. Timer 1-generated commonly used baud rates**

Baud Rate	f <sub>osc</sub>	SMOD	Timer 1		
			C/T	Mode	Reload Value
Mode 0 Max: 1MHz	12MHz	X	X	X	X
Mode 2 Max: 375K	12MHz	1	X	X	X
Modes 1, 3: 62.5K	12MHz	1	0	2	FFh
19.2K	11.059MHz	1	0	2	FDh
9.6K	11.059MHz	0	0	2	FDh
4.8K	11.059MHz	0	0	2	FAh
2.4K	11.059MHz	0	0	2	F4h
1.2K	11.059MHz	0	0	2	E8h
137.5	11.059MHz	0	0	2	1Dh
110	6MHz	0	0	2	72h
110	12MHz	0	0	1	FEEBh

The timer can be configured for either “timer” or “counter” operation. In the most typical applications, it is configured for “timer” operation (C/T2 = 0). “Timer” operation is a little different for Timer 2 when it's being used as a baud rate generator. Normally, as a timer it would increment every machine cycle (thus at the 1/6 the CPU clock frequency). In the case, the baud rate is given by the formula:

$$\text{Modes 1 and 3 Baud Rate} = f_{\text{OSC}} / (32 \times [65536 - (\text{RCAP2H}, \text{RCAP2L})])$$

where (RCAP2H, RCAP2L) is the content of RC2H and RC2L taken as a 16-bit unsigned integer.

Timer 2 also be used as the Baud Rate Generating mode. This mode is valid only if RCLK + TCLK = 1 in T2CON or in PCON.

*Note:* A roll-over in TH2 does not set TF2, and will not generate an interrupt. Therefore, the Timer Interrupt does not have to be disabled when Timer 2 is in the Baud Rate Generator mode.

*Note:* If EXEN2 is set, a 1-to-0 transition in T2EX will set EXF2 but will not cause a reload from (RCAP2H, RCAP2L) to (TH2, TL2). Thus when Timer 2 is in use as a baud rate generator, T2EX can be used as an extra external interrupt, if desired.

It should be noted that when Timer 2 is running (TR2 = 1) in “timer” function in the Baud Rate Generator mode, one should not try to READ or WRITE TH2 or TL2. Under these conditions the timer is being incremented every state time, and the results of a READ or WRITE may not be accurate. The RC registers may be read, but should not be written to, because a WRITE might overlap a reload and cause WRITE and/or reload errors. Turn the timer off (clear TR2) before accessing the Timer 2 or RC registers, in this case.

#### 12.2.4 More about Mode 0

Serial data enters and exits through RxD. TxD outputs the shift clock. 8 bits are transmitted/received: 8 data bits (LSB first). The baud rate is fixed at 1/12 the f<sub>OSC</sub>.

*Figure 26* shows a simplified functional diagram of the serial port in Mode 0, and associated timing.

Transmission is initiated by any instruction that uses SBUF as a destination register. The "WRITE to SBUF" signal at S6P2 also loads a '1' into the 9th position of the transmit shift register and tells the TX Control block to commence a transmission. The internal timing is such that one full machine cycle will elapse between "WRITE to SBUF" and activation of SEND.

SEND enables the output of the shift register to the alternate out-put function line of RxD and also enable SHIFT CLOCK to the alternate output function line of TxD. SHIFT CLOCK is low during S3, S4, and S5 of every machine cycle, and high during S6, S1, and S2. At S6P2 of every machine cycle in which SEND is active, the contents of the transmit shift are shifted to the right one position.

As data bits shift out to the right, zeros come in from the left. When the MSB of the data byte is at the output position of the shift register, then the '1' that was initially loaded into the 9th position, is just to the left of the MSB, and all positions to the left of that contain zeros. This condition flags the TX Control block to do one last shift and then deactivate SEND and set T1. Both of these actions occur at S1P1. Both of these actions occur at S1P1 of the 10th machine cycle after "WRITE to SBUF."

Reception is initiated by the condition REN = 1 and R1 = 0. At S6P2 of the next machine cycle, the RX Control unit writes the bits 11111110 to the receive shift register, and in the next clock phase activates RECEIVE.

RECEIVE enables SHIFT CLOCK to the alternate output function line of TxD. SHIFT CLOCK makes transitions at S3P1 and S6P1 of every machine cycle in which RECEIVE is active, the contents of the receive shift register are shifted to the left one position. The value that comes in from the right is the value that was sampled at the RxD pin at S5P2 of the same machine cycle.

As data bits come in from the right, '1s' shift out to the left. When the '0' that was initially loaded into the right-most position arrives at the left-most position in the shift register, it flags the RX Control block to do one last shift and load SBUF. At S1P1 of the 10th machine cycle after the WRITE to SCON that cleared RI, RECEIVE is cleared as RI is set.

### 12.2.5 More about Mode 1

Ten bits are transmitted (through TxD), or received (through RxD): a start Bit (0), 8 data bits (LSB first), and a Stop bit (1). On receive, the Stop bit goes into RB8 in SCON. In the UPSD321xx devices the baud rate is determined by the Timer 1 or Timer 2 overflow rate.

*Figure 28* shows a simplified functional diagram of the serial port in Mode 1, and associated timings for transmit receive.

Transmission is initiated by any instruction that uses SBUF as a destination register. The "WRITE to SBUF" signal also loads a '1' into the 9th bit position of the transmit shift register and flags the TX Control unit that a transmission is requested. Transmission actually commences at S1P1 of the machine cycle following the next rollover in the divide-by-16 counter. (Thus, the bit times are synchronized to the divide-by-16 counter, not to the "WRITE to SBUF" signal.)

The transmission begins with activation of SEND which puts the start bit at TxD. One bit time later, DATA is activated, which enables the output bit of the transmit shift register to TxD. The first shift pulse occurs one bit time after that.

As data bits shift out to the right, zeros are clocked in from the left. When the MSB of the data byte is at the output position of the shift register, then the '1' that was initially loaded into the 9th position is just to the left of the MSB, and all positions to the left of that contain zeros. This condition flags the TX Control unit to do one last shift and then deactivate SEND and set TI. This occurs at the 10th divide-by-16 rollover after "WRITE to SBUF."

Reception is initiated by a detected 1-to-0 transition at RxD. For this purpose RxD is sampled at a rate of 16 times whatever baud rate has been established. When a transition is detected, the divide-by-16 counter is immediately reset, and 1FFH is written into the input shift register. Resetting the divide-by-16 counter aligns its roll-overs with the boundaries of the incoming bit times.

The 16 states of the counter divide each bit time into 16ths. At the 7th, 8th, and 9th counter states of each bit time, the bit detector samples the value of RxD. The value accepted is the value that was seen in at least 2 of the 3 samples. This is done for noise rejection. If the value accepted during the first bit time is not '0,' the receive circuits are reset and the unit goes back to looking for an-other 1-to-0 transition. This is to provide rejection of false start bits. If the start bit proves valid, it is shifted into the input shift register, and reception of the rest of the frame will proceed.

As data bits come in from the right, '1s' shift out to the left. When the start bit arrives at the left-most position in the shift register (which in Mode 1 is a 9-bit register), it flags the RX Control block to do one last shift, load SBUF and RB8, and set RI. The signal to load SBUF and RB8, and to set RI, will be generated if, and only if, the following conditions are met at the time the final shift pulse is generated:

1. R1 = 0, and
2. Either SM2 = 0, or the received Stop bit = 1.

If either of these two conditions is not met, the received frame is irretrievably lost. If both conditions are met, the Stop bit goes into RB8, the 8 data bits go into SBUF, and RI is activated. At this time, whether the above conditions are met or not, the unit goes back to looking for a 1-to-0 transition in RxD.

### 12.2.6 More about Modes 2 and 3

Eleven bits are transmitted (through TxD), or received (through RxD): a Start bit (0), 8 data bits (LSB first), a programmable 9th data bit, and a Stop bit (1). On transmit, the 9th data bit (TB8) can be assigned the value of '0' or '1.' On receive, the data bit goes into RB8 in SCON. The baud rate is programmable to either 1/16 or 1/32 the CPU clock frequency in Mode 2. Mode 3 may have a variable baud rate generated from Timer 1.

*Figure 30* and *Figure 32* show a functional diagram of the serial port in Modes 2 and 3. The receive portion is exactly the same as in Mode 1. The transmit portion differs from Mode 1 only in the 9th bit of the transmit shift register.

Transmission is initiated by any instruction that uses SBUF as a destination register. The "WRITE to SBUF" signal also loads TB8 into the 9th bit position of the transmit shift register and flags the TX Control unit that a transmission is requested. Transmission commences at S1P1 of the machine cycle following the next roll-over in the divide-by-16 counter. (Thus, the bit times are synchronized to the divide-by-16 counter, not to the "WRITE to SBUF" signal.)

The transmission begins with activation of SEND, which puts the start bit at TxD. One bit time later, DATA is activated, which enables the output bit of the transmit shift register to TxD. The first shift pulse occurs one bit time after that. The first shift clocks a '1' (the Stop bit) into the 9th bit position of the shift register. There-after, only zeros are clocked in. Thus,

as data bits shift out to the right, zeros are clocked in from the left. When TB8 is at the output position of the shift register, then the Stop bit is just to the left of TB8, and all positions to the left of that contain zeros. This condition flags the TX Control unit to do one last shift and then deactivate SEND and set TI. This occurs at the 11th divide-by 16 rollover after "WRITE to SUBF."

Reception is initiated by a detected 1-to-0 transition at RxD. For this purpose RxD is sampled at a rate of 16 times whatever baud rate has been established. When a transition is detected, the divide-by-16 counter is immediately reset, and 1FFH is written to the input shift register.

At the 7th, 8th, and 9th counter states of each bit time, the bit detector samples the value of R-D. The value accepted is the value that was seen in at least 2 of the 3 samples. If the value accepted during the first bit time is not '0,' the receive circuits are reset and the unit goes back to looking for another 1-to-0 transition. If the Start bit proves valid, it is shifted into the input shift register, and reception of the rest of the frame will proceed.

As data bits come in from the right, '1s' shift out to the left. When the Start bit arrives at the left-most position in the shift register (which in Modes 2 and 3 is a 9-bit register), it flags the RX Control block to do one last shift, load SBUF and RB8, and set RI.

The signal to load SBUF and RB8, and to set RI, will be generated if, and only if, the following conditions are met at the time the final shift pulse is generated:

1. RI = 0, and
2. Either SM2 = 0, or the received 9th data bit = 1

If either of these conditions is not met, the received frame is irretrievably lost, and RI is not set. If both conditions are met, the received 9th data bit goes into RB8, and the first 8 data bits go into SBUF. One bit time later, whether the above conditions were met or not, the unit goes back to looking for a 1-to-0 transition at the RxD input.

Figure 26. Serial port Mode 0 block diagram

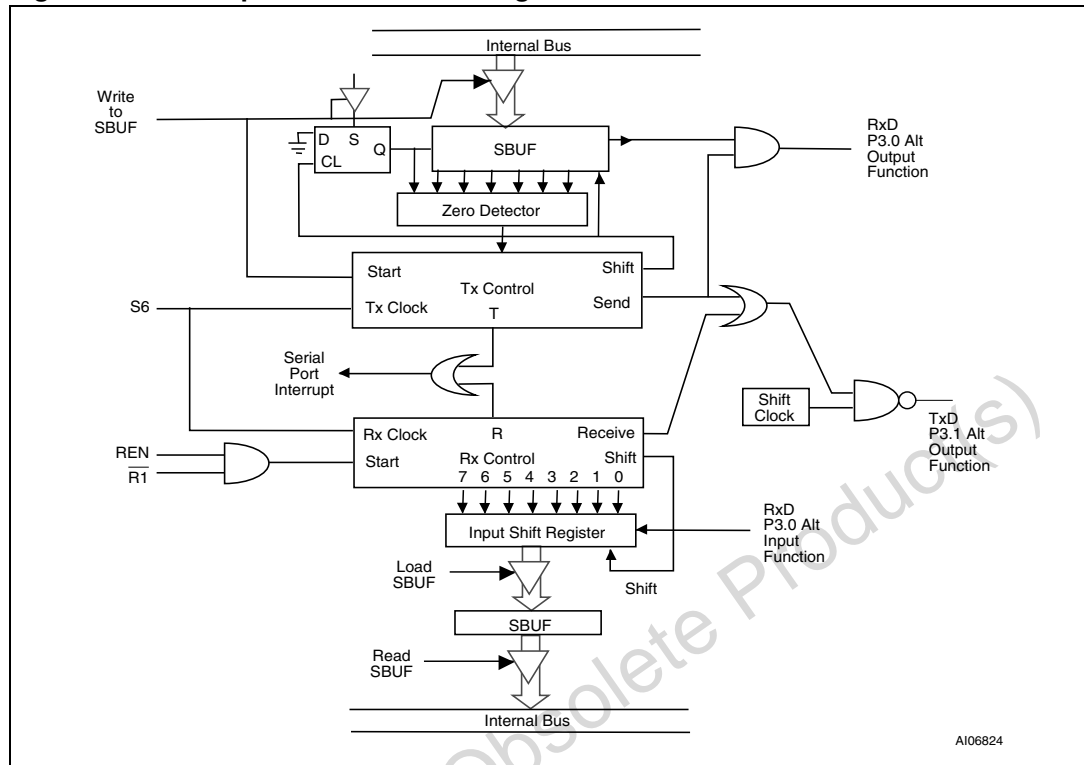

Figure 27. Serial port Mode 0 waveforms

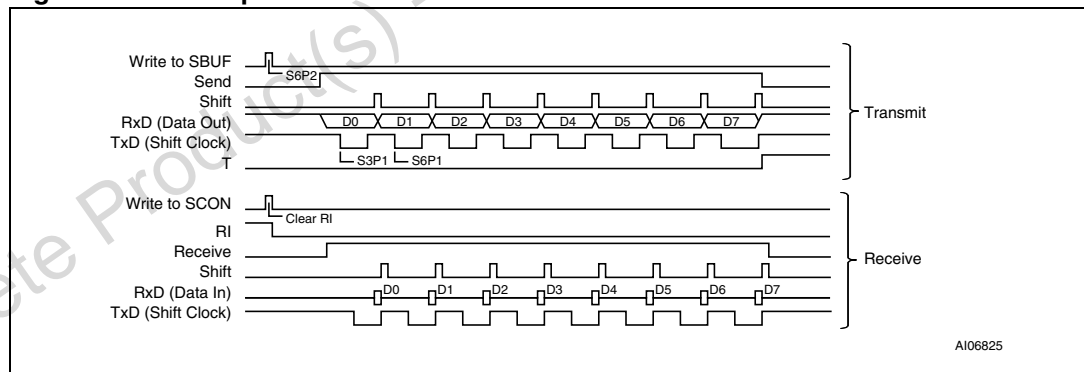
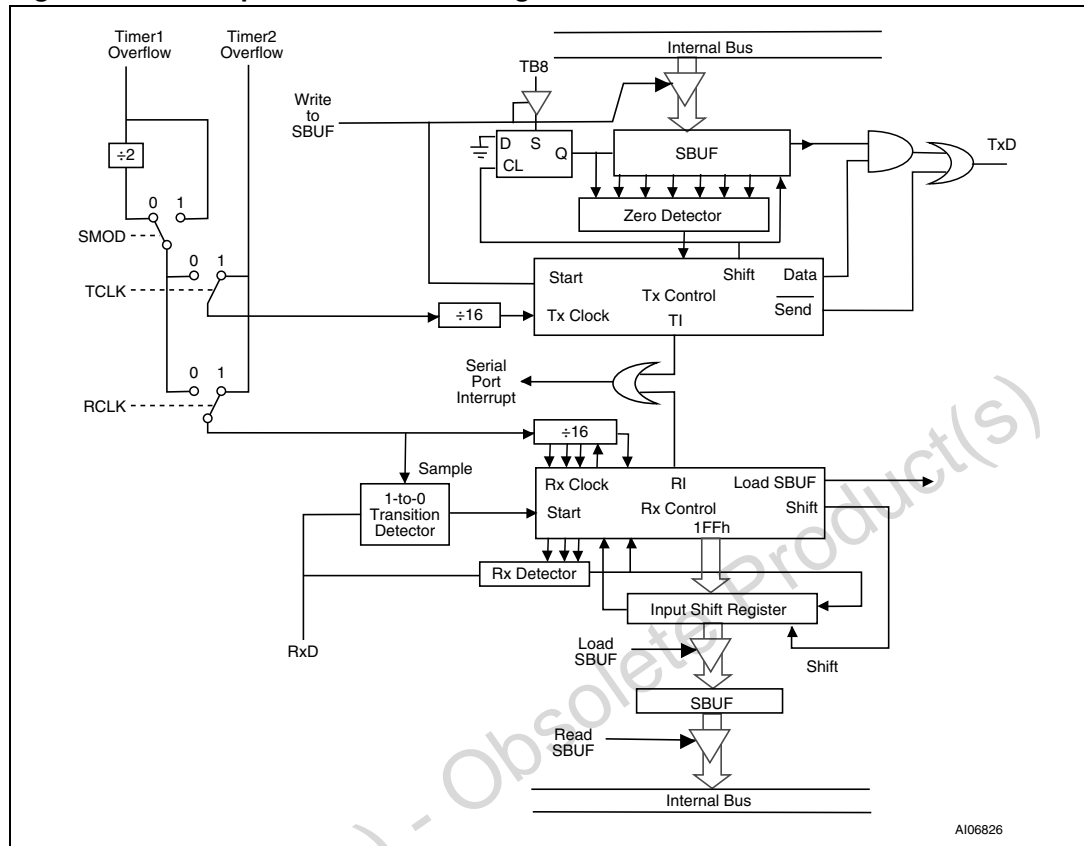

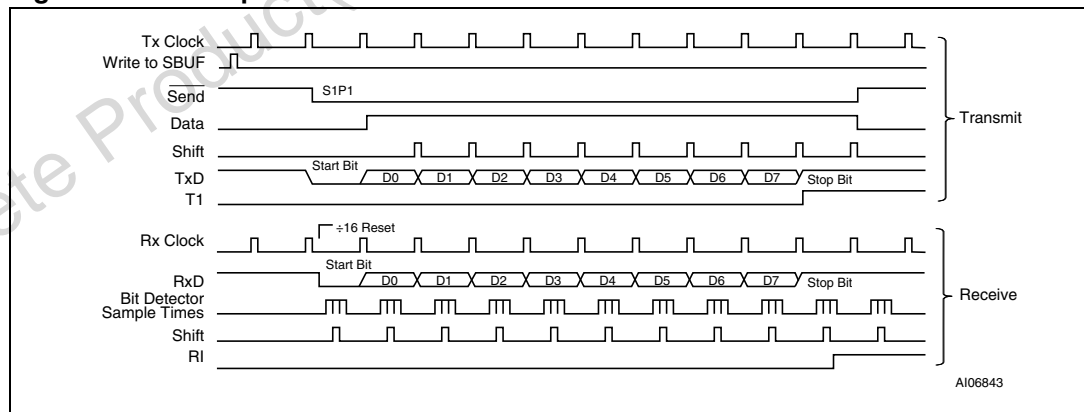

Figure 28. Serial port Mode 1 block diagram



AI06826

Figure 29. Serial port Mode 1 waveforms



AI06843

Figure 30. Serial port Mode 2 block diagram

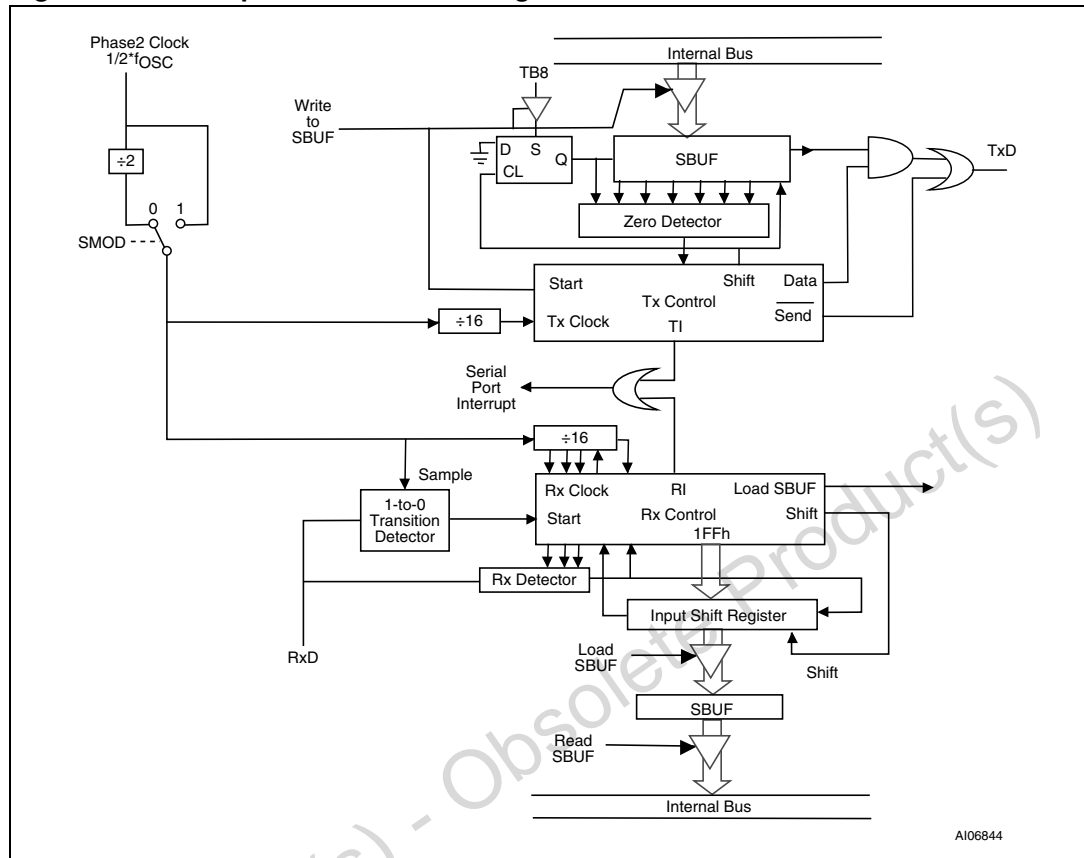

Figure 31. Serial port Mode 2 waveforms

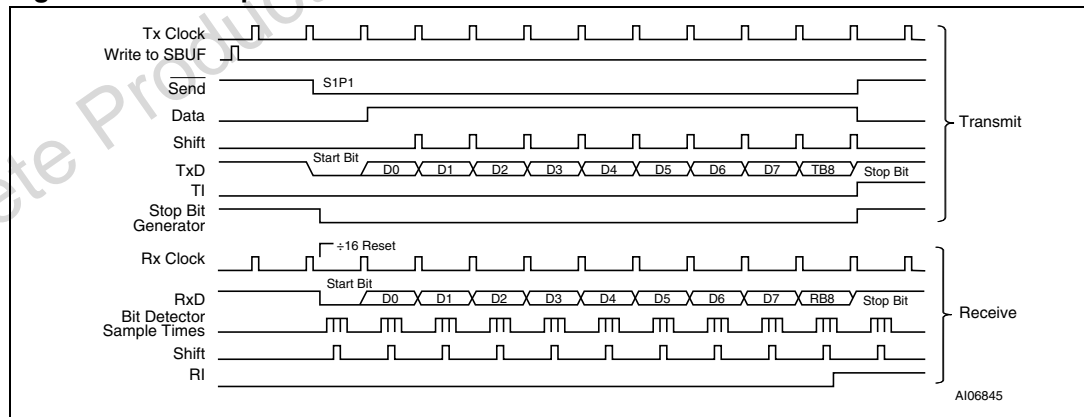
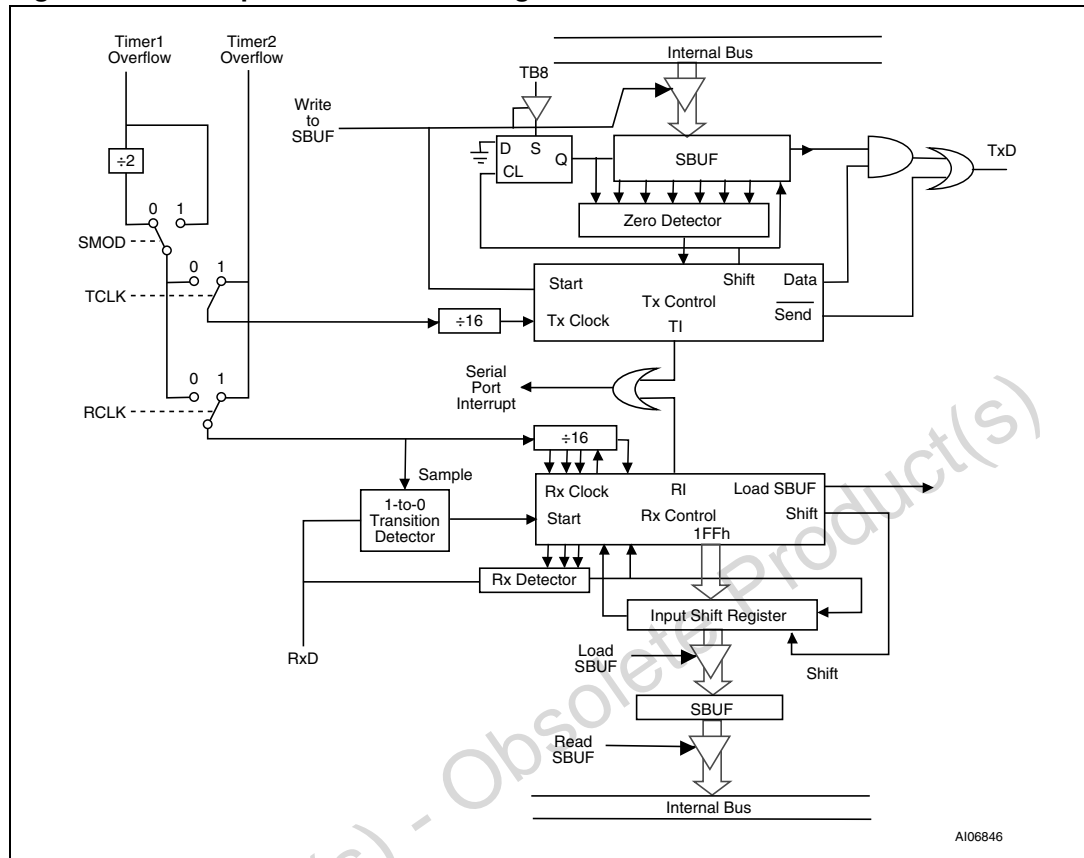
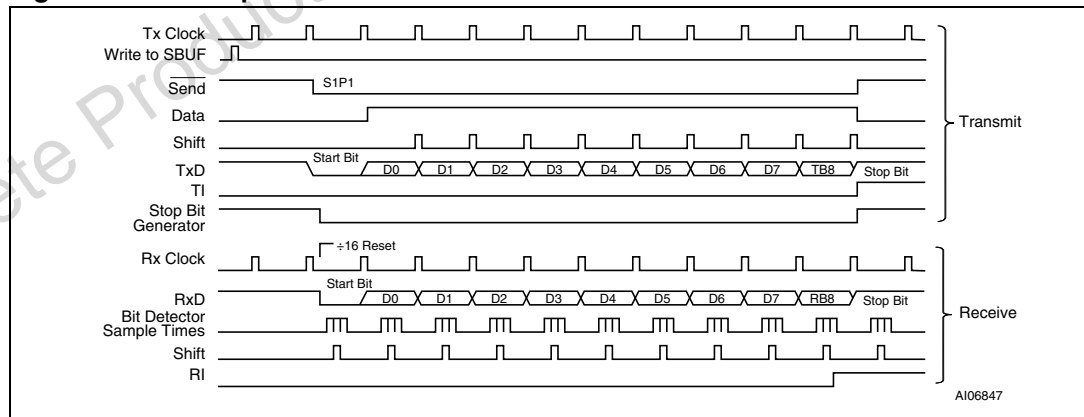

Figure 32. Serial port Mode 3 block diagram



A106846

Figure 33. Serial port Mode 3 waveforms



A106847

## 13 Analog-to-digital convertor (ADC)

The analog to digital (A/D) converter allows conversion of an analog input to a corresponding 8-bit digital value. The A/D module has four analog inputs, which are multiplexed into one sample and hold. The output of the sample and hold is the input into the converter, which generates the result via successive approximation. The analog supply voltage is connected to  $AV_{REF}$  of ladder resistance of A/D module.

The A/D module has two registers which are the control register ACON and A/D result register ADAT. The register ACON, shown in [Table 47](#), controls the operation of the A/D converter module. To use analog inputs, I/O is selected by P1SFS register. Also an 8-bit prescaler ASCL divides the main system clock input down to approximately 6MHz clock that is required for the ADC logic. Appropriate values need to be loaded into the prescaler based upon the main MCU clock frequency prior to use.

The processing of conversion starts when the Start bit ADST is set to '1.' After one cycle, it is cleared by hardware. The register ADAT contains the results of the A/D conversion. When conversion is completed, the result is loaded into the ADAT the A/D Conversion Status bit ADSF is set to '1.'

The block diagram of the A/D module is shown in [Figure 34](#). The A/D Status bit ADSF is set automatically when A/D conversion is completed, cleared when A/D conversion is in process.

The ASCL should be loaded with a value that results in a clock rate of approximately 6MHz for the ADC using the following formula:

$$\text{ADC clock input} = (f_{OSC} / 2) / (\text{Prescaler register value} + 1)$$

Where  $f_{OSC}$  is the MCU clock input frequency.

The conversion time for the ADC can be calculated as follows:

$$\text{ADC Conversion Time} = 8 \text{ clock} * 8\text{bits} * (\text{ADC Clock}) \approx 10.67\mu\text{sec (at 6MHz)}$$

### 13.1 ADC interrupt

The ADSF Bit in the ACON register is set to '1' when the A/D conversion is complete. The status bit can be driven by the MCU, or it can be configured to generate a falling edge interrupt when the conversion is complete.

The ADSF Interrupt is enabled by setting the ADSFINT Bit in the PCON register. Once the bit is set, the external INT1 Interrupt is disabled and the ADSF Interrupt takes over as INT1. INT1 must be configured as if it is an edge interrupt input. The INP1 pin (p3.3) is available for general I/O functions, or Timer1 gate control.

Figure 34. ADC block diagram

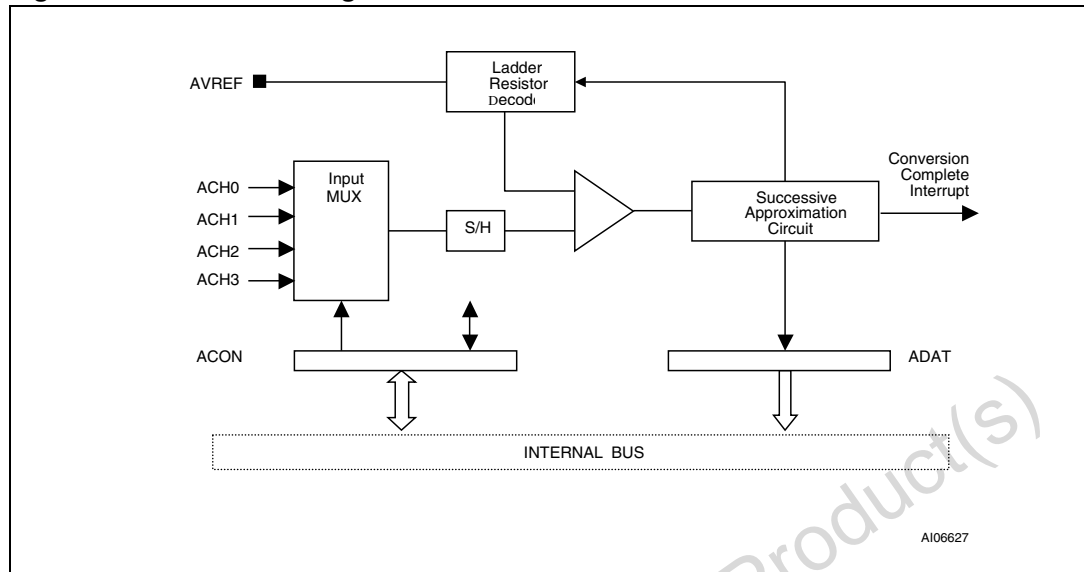

Table 46. ADC SFR memory map

SFR addr	Reg name	Bit register name								Reset value	Comments
		7	6	5	4	3	2	1	0		
95	ASCL									00	8-bit Prescaler for ADC clock
96	ADAT	ADAT7	ADAT6	ADAT5	ADAT4	ADAT3	ADAT2	ADAT1	ADAT0	00	ADC Data Register
97	ACON			ADEN		ADS1	ADS0	ADST	ADSF	00	ADC Control Register

Table 47. Description of the ACON bits

Bit	Symbol	Function	
7 to 6	—	Reserved	
5	ADEN	ADC Enable Bit:	0 : ADC shut off and consumes no operating current 1 : enable ADC
4	—	Reserved	
3 to 2	ADS1, ADS0	Analog channel select	
	0, 0	Channel0 (ACH0)	
	0, 1	Channel1 (ACH1)	
	1, 0	Channel2 (ACH2)	
	1, 1	Channel3 (ACH3)	
1	ADST	ADC Start bit:	0 : force to zero 1 : start an ADC; after one cycle, bit is cleared to '0'

**Table 47. Description of the ACON bits (continued)**

Bit	Symbol	Function	
0	ADSF	ADC Status bit:	0 : A/D conversion is in process 1 : A/D conversion is completed, not in process

**Table 48. ADC clock input**

MCU clock frequency	Prescaler register value	ADC clock
40MHz	2	6.7MHz
36MHz	2	6MHz
24MHz	1	6MHz
12MHz	0	6MHz

## 14 Pulse width modulation (PWM)

The PWM block has the following features:

- Four-channel, 8-bit PWM unit with 16-bit prescaler
- One-channel, 8-bit unit with programmable frequency and pulse width
- PWM Output with programmable polarity

### 14.1 4-channel PWM unit (PWM 0-3)

The 8-bit counter of a PWM counts module 256 (i.e., from 0 to 255, inclusive). The value held in the 8-bit counter is compared to the contents of the Special Function Register (PWM 0-3) of the corresponding PWM. The polarity of the PWM outputs is programmable and selected by the PWML Bit in PWMCON register. Provided the contents of a PWM 0-3 register is greater than the counter value, the corresponding PWM output is set HIGH (with PWML = 0). When the contents of this register is less than or equal to the counter value, the corresponding PWM output is set LOW (with PWML = 0). The pulse-width-ratio is therefore defined by the contents of the corresponding Special Function Register (PWM 0-3) of a PWM. By loading the corresponding Special Function Register (PWM 0-3) with either 00H or FFH, the PWM output can be retained at a constant HIGH or LOW level respectively (with PWML = 0).

For each PWM unit, there is a 16-bit Prescaler that are used to divide the main system clock to form the input clock for the corresponding PWM unit. This prescaler is used to define the desired repetition rate for the PWM unit. SFR registers B1h - B2h are used to hold the 16-bit divisor values.

The repetition frequency of the PWM output is given by:

$$f_{\text{PWM}8} = (f_{\text{OSC}} / \text{prescaler0}) / (2 \times 256)$$

And the input clock frequency to the PWM counters is =  $f_{\text{OSC}} / 2 / (\text{prescaler data value} + 1)$

See [Section 7: I/O ports \(MCU module\)](#) for more information on how to configure the Port 4 pin as PWM output.

Figure 35. Four-channel 8-bit PWM block diagram

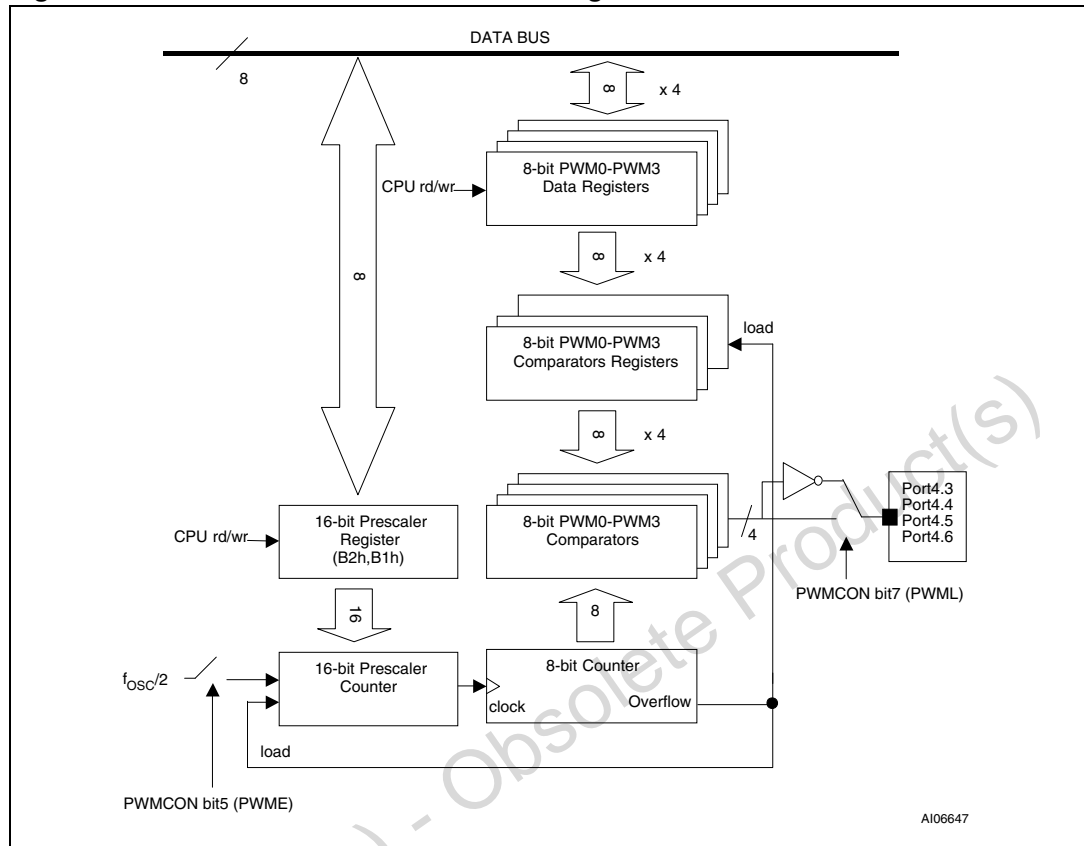

Table 49. PWM SFR memory map

SFR addr	Reg name	Bit register name								Reset value	Comments
		7	6	5	4	3	2	1	0		
A1	PWMCON	PWML	PWMP	PWME	CFG4	CFG3	CFG2	CFG1	CFG0	00	PWM Control Polarity
A2	PWM0									00	PWM0 Output Duty Cycle
A3	PWM1									00	PWM1 Output Duty Cycle
A4	PWM2									00	PWM2 Output Duty Cycle
A5	PWM3									00	PWM3 Output Duty Cycle
AA	PWM4P									00	PWM 4 Period
AB	PWM4W									00	PWM 4 Pulse Width
B1	PSCL0L									00	Prescaler 0 Low (8-bit)



Table 49. PWM SFR memory map (continued)

SFR addr	Reg name	Bit register name								Reset value	Comments
		7	6	5	4	3	2	1	0		
B2	PSCL0H									00	Prescaler 0 High (8-bit)
B3	PSCL1L									00	Prescaler 1 Low (8-bit)
B4	PSCL1H									00	Prescaler 1 High (8-bit)

PWMCON register bit definition:

- PWML = PWM 0-3 polarity control
- PWMP = PWM 4 polarity control
- PWME = PWM enable (0 = disabled, 1= enabled)
- CFG3..CFG0 = PWM 0-3 Output (0 = Open Drain; 1 = Push-Pull)
- CFG4 = PWM 4 Output (0 = Open Drain; 1 = Push-Pull)

### 14.2 Programmable period 8-bit PWM

The PWM 4 channel can be programmed to provide a PWM output with variable pulse width and period. The PWM 4 has a 16-bit Prescaler, an 8-bit Counter, a Pulse Width Register, and a Period Register. The Pulse Width Register defines the PWM pulse width time, while the Period Register defines the period of the PWM. The input clock to the Prescaler is  $f_{OSC}/2$ . The PWM 4 channel is assigned to Port 4.7.

Figure 36. Programmable 4-channel PWM block diagram

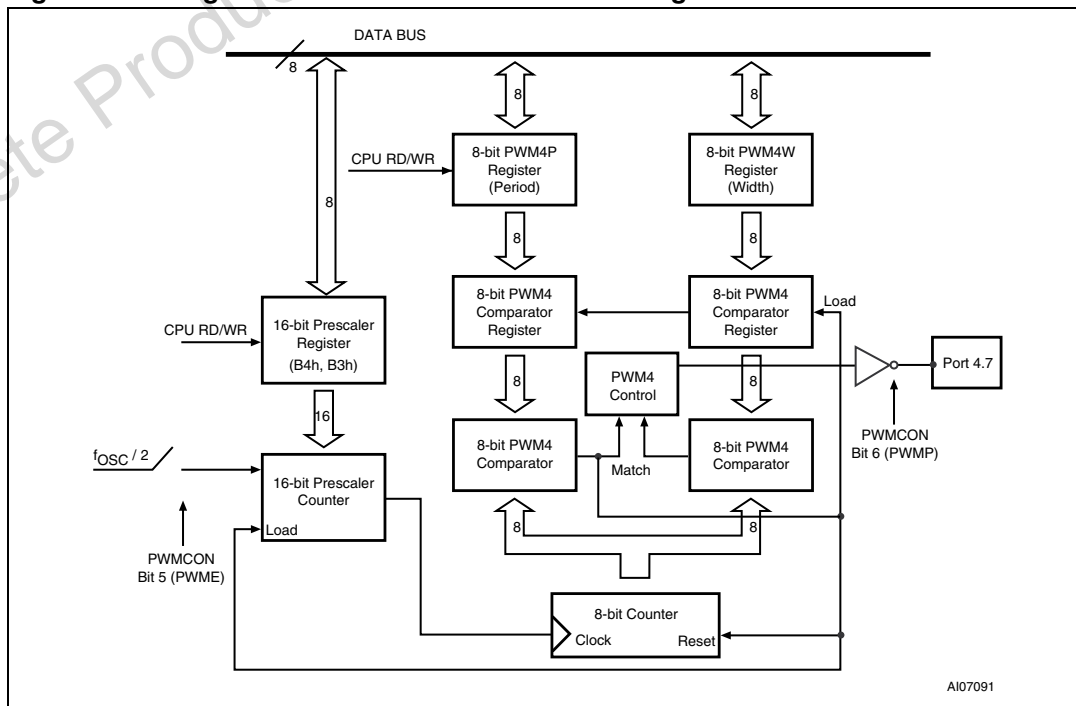

### 14.3 PWM 4-channel operation

The 16-bit Prescaler1 divides the input clock ( $f_{OSC}/2$ ) to the desired frequency, the resulting clock runs the 8-bit Counter of the PWM 4 channel. The input clock frequency to the PWM 4 Counter is:

$$f_{PWM4} = (f_{OSC}/2)/(Prescaler1 \text{ data value} + 1)$$

When the Prescaler1 Register (B4h, B3h) is set to data value '0,' the maximum input clock frequency to the PWM 4 Counter is  $f_{OSC}/2$  and can be as high as 20MHz.

The PWM 4 Counter is a free-running, 8-bit counter. The output of the counter is compared to the Compare Registers, which are loaded with data from the Pulse Width Register (PWM4W, ABh) and the Period Register (PWM4P, AAh). The Pulse Width Register defines the pulse duration or the Pulse Width, while the Period Register defines the period of the PWM. When the PWM 4 channel is enabled, the register values are loaded into the Comparator Registers and are compared to the Counter output. When the content of the counter is equal to or greater than the value in the Pulse Width Register, it sets the PWM 4 output to low (with PWMP Bit = 0). When the Period Register equals to the PWM4 Counter, the Counter is cleared, and the PWM 4 channel output is set to logic 'high' level (beginning of the next PWM pulse).

The Period Register cannot have a value of "00" and its content should always be greater than the Pulse Width Register.

The Prescaler1 Register, Pulse Width Register, and Period Register can be modified while the PWM 4 channel is active. The values of these registers are automatically loaded into the Prescaler Counter and Comparator Registers when the current PWM 4 period ends.

The PWMCON Register (Bits 5 and 6) controls the enable/disable and polarity of the PWM 4 channel.

**Figure 37. PWM 4 with programmable pulse width and frequency**

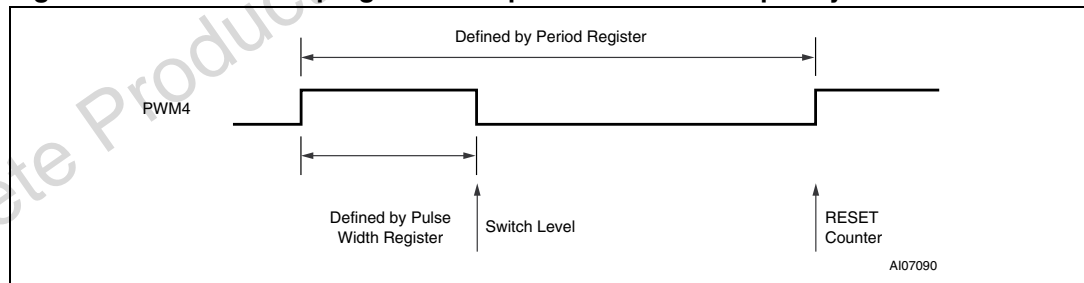

# 15 I<sup>2</sup>C interface

There are two serial I<sup>2</sup>C ports implemented in the UPSD321xx devices.

The serial port supports the twin line I<sup>2</sup>C-bus, consists of a data line (SDAx) and a clock line (SCLx). Depending on the configuration, the SDA and SCL lines may require pull-up resistors.

- SDA1, SCL1: the serial port line for DDC Protocol
- SDA2, SCL2: the serial port line for general I<sup>2</sup>C bus connection

In both I<sup>2</sup>C interfaces, these lines also function as I/O port lines as follows.

- SDA1 / P4.0, SCL1 / P4.1, SDA2 / P3.6, SCL2 / P3.7

The system is unique because data transport, clock generation, address recognition and bus control arbitration are all controlled by hardware.

The I<sup>2</sup>C serial I/O has complete autonomy in byte handling and operates in 4 modes.

- Master transmitter
- Master receiver
- Slave transmitter
- Slave receiver

These functions are controlled by the SFRs.

- SxCON: the control of byte handling and the operation of 4 mode.
- SxSTA: the contents of its register may also be used as a vector to various service routines.
- SxDAT: data shift register.
- SxADR: slave address register. Slave address recognition is performed by On-Chip H/W.

**Figure 38. Block diagram of the I<sup>2</sup>C bus serial I/O**

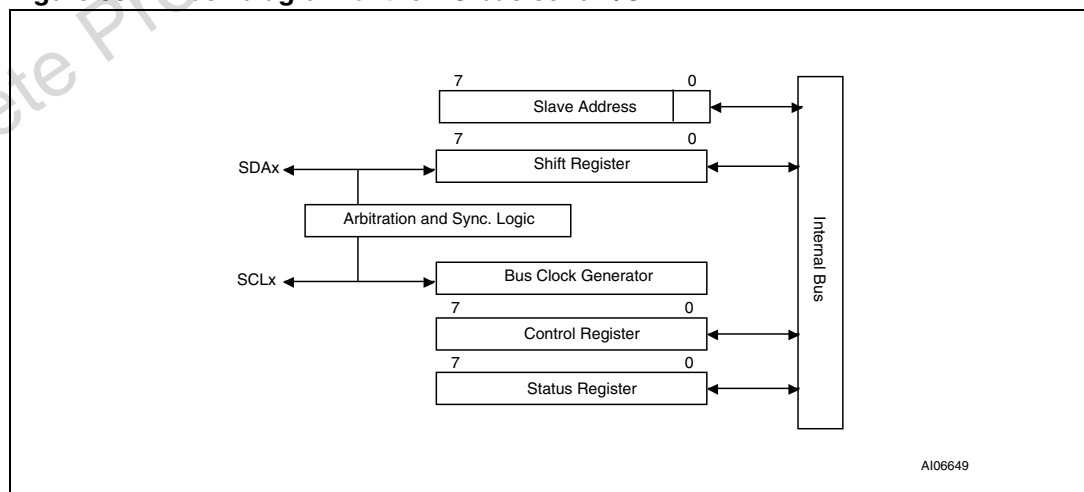

**Table 50. Serial control register (SxCON: S1CON, S2CON)**

7	6	5	4	3	2	1	0
CR2	ENII	STA	STO	ADDR	AA	CR1	CR0

**Table 51. Description of the SxCON bits**

Bit	Symbol	Function
7	CR2	This bit along with Bits CR1 and CR0 determines the serial clock frequency when SIO is in the Master mode.
6	ENII	Enable IIC. When ENI1 = 0, the IIC is disabled. SDA and SCL outputs are in the high impedance state.
5	STA	START flag. When this bit is set, the SIO H/W checks the status of the I <sup>2</sup> C-bus and generates a START condition if the bus free. If the bus is busy, the SIO will generate a repeated START condition when this bit is set.
4	STO	STOP flag. With this bit set while in Master mode a STOP condition is generated. When a STOP condition is detected on the I <sup>2</sup> C-bus, the I <sup>2</sup> C hardware clears the STO flag. <b>Note:</b> This bit have to be set before 1 cycle interrupt period of STOP. That is, if this bit is set, STOP condition in Master mode is generated after 1 cycle interrupt period.
3	ADDR	This bit is set when address byte was received. Must be cleared by software.
2	AA	Acknowledge enable signal. If this bit is set, an acknowledge (low level to SDA) is returned during the acknowledge clock pulse on the SCL line when: <ul style="list-style-type: none"> <li>• Own slave address is received</li> <li>• A data byte is received while the device is programmed to be a Master Receiver</li> <li>• A data byte is received while the device is a selected Slave Receiver.</li> </ul> When this bit is reset, no acknowledge is returned. SIO release SDA line as high during the acknowledge clock pulse.
1	CR1	These two bits along with the CR2 Bit determine the serial clock frequency when SIO is in the Master mode.
0	CR0	

**Table 52. Selection of the serial clock frequency SCL in Master mode**

CR2	CR1	CR0	f <sub>osc</sub> divisor	Bit rate (kHz) at f <sub>osc</sub>			
				12 MHz	24 MHz	36 MHz	40 MHz
0	0	0	16	375	750	X	X
0	0	1	24	250	500	750	833
0	1	0	30	200	400	600	666
0	1	1	60	100	200	300	333
1	0	0	120	50	100	150	166
1	0	1	240	25	50	75	83
1	1	0	480	12.5	25	37.5	41
1	1	1	960	6.25	12.5	18.75	20

### 15.1 Serial status register (SxSTA: S1STA, S2STA)

SxSTA is a “Read-only” register. The contents of this register may be used as a vector to a service routine. This optimized the response time of the software and consequently that of the I<sup>2</sup>C-bus. The status codes for all possible modes of the I<sup>2</sup>C-bus interface are given Table [Table 54](#).

This flag is set, and an interrupt is generated, after any of the following events occur.

1. Own slave address has been received during AA = 1: ack\_int
2. The general call address has been received while GC(SxADR.0) = 1 and AA = 1:
3. A data byte has been received or transmitted in Master mode (even if arbitration is lost): ack\_int
4. A data byte has been received or transmitted as selected slave: ack\_int
5. A stop condition is received as selected slave receiver or transmitter: stop\_int

### 15.2 Data shift register (SxDAT: S1DAT, S2DAT)

SxDAT contains the serial data to be transmitted or data which has just been received. The MSB (Bit 7) is transmitted or received first; that is, data shifted from right to left.

**Table 53. Serial status register (SxSTA)**

7	6	5	4	3	2	1	0
GC	STOP	INTR	TX_MODE	BBUSY	BLOST	/ACK_REP	SLV

**Table 54. Description of the SxSTA bits**

Bit	Symbol	Function
7	GC	General Call Flag
6	STOP	Stop Flag. This bit is set when a STOP condition is received
5	INTR <sup>(1,2)</sup>	Interrupt Flag. This bit is set when an I <sup>2</sup> C Interrupt condition is requested
4	TX_MODE	Transmission mode Flag. This bit is set when the I <sup>2</sup> C is a transmitter; otherwise this bit is reset
3	BBUSY	Bus Busy Flag. This bit is set when the bus is being used by another master; otherwise, this bit is reset
2	BLOST	Bus Lost Flag. This bit is set when the master loses the bus contention; otherwise this bit is reset
1	/ACK_REP	Acknowledge Response Flag. This bit is set when the receiver transmits the not acknowledge signal This bit is reset when the receiver transmits the acknowledge signal
0	SLV	Slave mode Flag. This bit is set when the I <sup>2</sup> C plays role in the Slave mode; otherwise this bit is reset

1. Interrupt Flag bit (INTR, SxSTA Bit 5) is cleared by Hardware as reading SxSTA register.
2. I<sup>2</sup>C interrupt flag (INTR) can occur in below case. (except DDC2B mode at SWENB=0)

**Table 55. Data shift register (SxDAT: S1DAT, S2DAT)**

7	6	5	4	3	2	1	0
SxDAT7	SxDAT6	SxDAT5	SxDAT4	SxDAT3	SxDAT2	SxDAT1	SxDAT0

### 15.3 Address register (SxADR: S1ADR, S2ADR)

This 8-bit register may be loaded with the 7-bit slave address to which the controller will respond when programmed as a slave receive/transmitter.

The Start/Stop Hold Time Detection and System Clock registers ([Table 57](#) and [Table 58](#)) are included in the I<sup>2</sup>C unit to specify the start/stop detection time to work with the large range of MCU frequency values supported. For example, with a system clock of 40MHz.

**Table 56. Address register (SxADR)**

7	6	5	4	3	2	1	0
SLA6	SLA5	SLA4	SLA3	SLA2	SLA1	SLA0	—

1. SLA6 to SLA0: Own slave address.

**Table 57. Start /Stop Hold Time Detection Register (S1SETUP, S2SETUP)**

	Address	Register Name	Reset Value	Note
SFR	D1h	S1SETUP	00h	To control the start/stop hold time detection for the DDC module in Slave mode
	D2h	S2SETUP	00h	To control the start/stop hold time detection for the multi-master I <sup>2</sup> C module in Slave mode

**Table 58. System clock of 40MHz**

S1SETUP, S2SETUP Register Value	Number of Sample Clock (f <sub>OSC</sub> /2 -> 50ns)	Required Start/Stop Hold Time	Note
00h	1EA	50ns	When Bit 7 (enable bit) = 0, the number of sample clock is 1EA (ignore Bit 6 to Bit 0)
80h	1EA	50ns	
81h	2EA	100ns	
82h	3EA	150ns	
...	...	...	
8Bh	12EA	600ns	Fast mode I <sup>2</sup> C Start/Stop hold time specification
...	...	...	
FFh	128EA	6000ns	

**Table 59. System clock setup examples**

System Clock	S1SETUP, S2SETUP Register Value	Number of Sample Clock	Required Start/Stop Hold Time
40MHz ( $f_{OSC}/2 \rightarrow 50\text{ns}$ )	8Bh	12 EA	600ns
30MHz ( $f_{OSC}/2 \rightarrow 66.6\text{ns}$ )	89h	9 EA	600ns
20MHz ( $f_{OSC}/2 \rightarrow 100\text{ns}$ )	86h	6 EA	600ns
8MHz ( $f_{OSC}/2 \rightarrow 250\text{ns}$ )	83h	3 EA	750ns

Obsolete Product(s) - Obsolete Product(s)

## 16 USB hardware

The characteristics of USB hardware are as follows:

- Complies with the Universal Serial Bus specification Rev. 1.1
- Integrated SIE (Serial Interface Engine), FIFO memory and transceiver
- Low speed (1.5Mbit/s) device capability
- Supports control endpoint0 and interrupt endpoint1 and 2
- USB clock input must be 6MHz (requires MCU clock frequency to be 12, 24, or 36MHz).

The analog front-end is an on-chip generic USB transceiver. It is designed to allow voltage levels equal to  $V_{DD}$  from the standard logic to interface with the physical layer of the Universal Serial Bus. It is capable of receiving and transmitting serial data at low speed (1.5Mb/s).

The SIE is the digital-front-end of the USB block. This module recovers the 1.5MHz clock, detects the USB sync word and handles all low-level USB protocols and error checking. The bit-clock recovery circuit recovers the clock from the incoming USB data stream and is able to track jitter and frequency drift according to the USB specification. The SIE also translates the electrical USB signals into bytes or signals. Depending upon the device USB address and the USB endpoint.

Address, the USB data is directed to the correct endpoint on SIE interface. The data transfer of this H/W could be of type control or interrupt.

The device's USB address and the enabling of the endpoints are programmable in the SIE configuration header.

### 16.1 USB related registers

The USB block is controlled via seven registers in the memory: (UADR, UCON0, UCON1, UCON2, UISTA, UIEN, and USTA).

Three memory locations on chip which communicate the USB block are:

- USB endpoint0 data transmit register (UDT0)
- USB endpoint0 data receive register (UDR0)
- USB endpoint1 data transmit register (UDT1)

**Table 60. USB address register (UADR: 0EEh)**

7	6	5	4	3	2	1	0
USBEN	UADD6	UADD5	UADD4	UADD3	UADD2	UADD1	UADD0



**Table 61. Description of the UADR Bits**

Bit	Symbol	R/W	Function
7	USBEN	R/W	USB Function Enable Bit. When USBEN is clear, the USB module will not respond to any tokens from host. $\overline{\text{RESET}}$ clears this bit.
6 to 0	UADD6 to UADD0	R/W	Specify the USB address of the device. $\overline{\text{RESET}}$ clears these bits.

**Table 62. USB interrupt enable register (UIEN: 0E9h)**

7	6	5	4	3	2	1	0
SUSPNDI	RSTE	RSTFIE	TXD0IE	RXD0IE	TXD1IE	EOPIE	RESUMI

**Table 63. Description of the UIEN bits**

Bit	Symbol	R/W	Function
7	SUSPNDI	R/W	Enable SUSPND Interrupt
6	RSTE	R/W	Enable USB Reset; also resets the CPU and PSD modules when bit is set to '1.'
5	RSTFIE	R/W	Enable RSTF (USB Bus Reset Flag) Interrupt
4	TXD0IE	R/W	Enable TXD0 Interrupt
3	RXD0IE	R/W	Enable RXD0 Interrupt
2	TXD1IE	R/W	Enable TXD1 Interrupt
1	EOPIE	R/W	Enable EOP Interrupt
0	RESUMI	R/W	Enable USB Resume Interrupt when it is the Suspend mode

**Table 64. USB interrupt status register (UISTA: 0E8h)**

7	6	5	4	3	2	1	0
SUSPND	—	RSTF	TXD0F	RXD0F	TXD1F	EOPF	RESUMF

**Table 65. Description of the UISTA bits**

Bit	Symbol	R/W	Function
7	SUSPND	R/W	USB Suspend Mode Flag. To save power, this bit should be set if a 3ms constant idle state is detected on USB bus. Setting this bit stops the clock to the USB and causes the USB module to enter Suspend mode. Software must clear this bit after the Resume flag (RESUMF) is set while this Resume Interrupt Flag is serviced
6	—	—	Reserved
5	RSTF	R	USB Reset Flag. This bit is set when a valid $\overline{\text{RESET}}$ signal state is detected on the D+ and D- lines. When the RSTE bit in the UIEN Register is set, this reset detection will also generate an internal reset signal to reset the CPU and other peripherals including the USB module.

**Table 65. Description of the UISTA bits (continued)**

Bit	Symbol	R/W	Function
4	TXD0F	R/W	Endpoint0 Data Transmit Flag. This bit is set after the data stored in Endpoint 0 transmit buffers has been sent and an ACK handshake packet from the host is received. Once the next set of data is ready in the transmit buffers, software must clear this flag. To enable the next data packet transmission, TX0E must also be set. If TXD0F Bit is not cleared, a NAK handshake will be returned in the next IN transactions. $\overline{\text{RESET}}$ clears this bit.
3	RXD0F	R/W	Endpoint0 Data Receive Flag. This bit is set after the USB module has received a data packet and responded with ACK handshake packet. Software must clear this flag after all of the received data has been read. Software must also set RX0E Bit to one to enable the next data packet reception. If RXD0F Bit is not cleared, a NAK handshake will be returned in the next OUT transaction. $\overline{\text{RESET}}$ clears this bit.
2	TXD1F	R/W	Endpoint1 / Endpoint2 Data Transmit Flag. This bit is shared by Endpoints 1 and Endpoints 2. It is set after the data stored in the shared Endpoint 1/ Endpoint 2 transmit buffer has been sent and an ACK handshake packet from the host is received. Once the next set of data is ready in the transmit buffers, software must clear this flag. To enable the next data packet transmission, TX1E must also be set. If TXD1F Bit is not cleared, a NAK handshake will be returned in the next IN transaction. $\overline{\text{RESET}}$ clears this bit.
1	EOPF	R/W	End of Packet Flag. This bit is set when a valid End of Packet sequence is detected on the D+ and D-line. Software must clear this flag. $\overline{\text{RESET}}$ clears this bit.
0	RESUMF	R/W	Resume Flag. This bit is set when USB bus activity is detected while the SUSPND Bit is set. Software must clear this flag. $\overline{\text{RESET}}$ clears this bit.

**Table 66. USB Endpoint0 transmit control register (UCON0: 0EAh)**

7	6	5	4	3	2	1	0
TSEQ0	STALL0	TX0E	RX0E	TP0SIZ3	TP0SIZ2	TP0SIZ1	TP0SIZ0

**Table 67. Description of the UCON0 bits**

Bit	Symbol	R/W	Function
7	TSEQ0	R/W	Endpoint0 Data Sequence Bit. (0=DATA0, 1=DATA1) This bit determines which type of data packet (DATA0 or DATA1) will be sent during the next IN transaction. Toggling of this bit must be controlled by software. <u>RESET</u> clears this bit
6	STALL0	R/W	Endpoint0 Force Stall Bit. This bit causes Endpoint 0 to return a STALL handshake when polled by either an IN or OUT token by the USB Host Controller. The USB hardware clears this bit when a SETUP token is received. <u>RESET</u> clears this bit.
5	TX0E	R/W	Endpoint0 Transmit Enable. This bit enables a transmit to occur when the USB Host Controller sends an IN token to Endpoint 0. Software should set this bit when data is ready to be transmitted. It must be cleared by software when no more Endpoint 0 data needs to be transmitted. If this bit is '0' or the TXD0F is set, the USB will respond with a NAK handshake to any Endpoint 0 IN tokens. <u>RESET</u> clears this bit.
4	RX0E	R/W	Endpoint0 receive enable. This bit enables a receive to occur when the USB Host Controller sends an OUT token to Endpoint 0. Software should set this bit when data is ready to be received. It must be cleared by software when data cannot be received. If this bit is '0' or the RXD0F is set, the USB will respond with a NAK handshake to any Endpoint 0 OUT tokens. <u>RESET</u> clears this bit.
3 to 0	TP0SIZ3 to TP0SIZ0	R/W	The number of transmit data bytes. These bits are cleared by <u>RESET</u> .

**Table 68. USB Endpoint1 (and 2) transmit control register (UCON1: 0EBh)**

7	6	5	4	3	2	1	0
TSEQ1	EP12SEL	TX1E	FRESUM	TP1SIZ3	TP1SIZ2	TP1SIZ1	TP1SIZ0

**Table 69. Description of the UCON1 bits**

Bit	Symbol	R/W	Function
7	TSEQ1	R/W	Endpoint 1/ Endpoint 2 Transmit Data Packet PID. (0=DATA0, 1=DATA1) This bit determines which type of data packet (DATA0 or DATA1) will be sent during the next IN transaction directed to Endpoint 1 or Endpoint 2. Toggling of this bit must be controlled by software. $\overline{\text{RESET}}$ clears this bit.
6	EP12SEL	R/W	Endpoint 1/ Endpoint 2 Transmit Selection. (0=Endpoint 1, 1=Endpoint 2) This bit specifies whether the data inside the registers UDT1 are used for Endpoint 1 or Endpoint 2. If all the conditions for a successful Endpoint 2 USB response to a hosts IN token are satisfied (TXD1F=0, TX1E=1, STALL2=0, and EP2E=1) except that the EP12SEL Bit is configured for Endpoint 1, the USB responds with a NAK handshake packet. $\overline{\text{RESET}}$ clears this bit.
5	TX1E	R/W	Endpoint1 / Endpoint2 Transmit Enable. This bit enables a transmit to occur when the USB Host Controller send an IN token to Endpoint 1 or Endpoint 2. The appropriate endpoint enable bit, EP1E or EP2E Bit in the UCON2 register, should also be set. Software should set the TX1E Bit when data is ready to be transmitted. It must be cleared by software when no more data needs to be transmitted. If this bit is '0' or TXD1F is set, the USB will respond with a NAK handshake to any Endpoint 1 or Endpoint 2 directed IN token. $\overline{\text{RESET}}$ clears this bit.
4	FRESUM	R/W	Force Resume. This bit forces a resume state ("K" on non-idle state) on the USB data lines to initiate a remote wake-up. Software should control the timing of the forced resume to be between 10ms and 15ms. Setting this bit will not cause the RESUMF Bit to set.
3 to 0	TP1SIZ3 to TP1SIZ0	R/W	The number of transmit data bytes. These bits are cleared by $\overline{\text{RESET}}$ .

**Table 70. USB control register (UCON2: 0ECh)**

7	6	5	4	3	2	1	0
—	—	—	SOUT	EP2E	EP1E	STALL2	STALL1

**Table 71. Description of the UCON2 bits**

Bit	Symbol	R/W	Function
7 to 5	—	—	Reserved
4	SOUT	R/W	Status out is used to automatically respond to the OUT of a control READ transfer
3	EP2E	R/W	Endpoint2 enable. $\overline{\text{RESET}}$ clears this bit

**Table 71. Description of the UCON2 bits (continued)**

Bit	Symbol	R/W	Function
2	EP1E	R/W	Endpoint1 enable. $\overline{\text{RESET}}$ clears this bit
1	STALL2	R/W	Endpoint2 Force Stall Bit. $\overline{\text{RESET}}$ clears this bit
0	STALL1	R/W	Endpoint1 Force Stall Bit. $\overline{\text{RESET}}$ clears this bit

**Table 72. USB Endpoint0 status register (USTA: 0EDh)**

7	6	5	4	3	2	1	0
RSEQ	SETUP	IN	OUT	RP0SIZ3	RP0SIZ2	RP0SIZ1	RP0SIZ0

**Table 73. Description of the USTA bits**

Bit	Symbol	R/W	Function
7	RSEQ	R/W	Endpoint0 receive data packet PID. (0=DATA0, 1=DATA1) This bit will be compared with the type of data packet last received for Endpoint0
6	SETUP	R	SETUP Token Detect Bit. This bit is set when the received token packet is a SETUP token, PID = b1101.
5	IN	R	IN Token Detect Bit. This bit is set when the received token packet is an IN token.
4	OUT	R	OUT Token Detect Bit. This bit is set when the received token packet is an OUT token.
3 to 0	RP0SIZ3 to RP0SIZ0	R	The number of data bytes received in a DATA packet

**Table 74. USB Endpoint0 data receive register (UDR0: 0EFh)**

7	6	5	4	3	2	1	0
UDR0.7	UDR0.6	UDR0.5	UDR0.4	UDR0.3	UDR0.2	UDR0.1	UDR0.0

**Table 75. USB Endpoint0 data transmit register (UDT0: 0E7h)**

7	6	5	4	3	2	1	0
UDT0.7	UDT0.6	UDT0.5	UDT0.4	UDT0.3	UDT0.2	UDT0.1	UDT0.0

**Table 76. USB Endpoint1 data transmit register (UDT1: 0E6h)**

7	6	5	4	3	2	1	0
UDT1.7	UDT1.6	UDT1.5	UDT1.4	UDT1.3	UDT1.2	UDT1.1	UDT1.0

The USCL 8-bit prescaler register for USB is at E1h. The USCL should be loaded with a value that results in a clock rate of 6 MHz for the USB using the following formula:

$$\text{USB clock input} = (f_{\text{OSC}} / 2) / (\text{Prescaler register value} + 1)$$

Where  $f_{\text{OSC}}$  is the MCU clock input frequency.

*Note:* USB works ONLY with the MCU Clock frequencies of 12, 24, or 36 MHz. The Prescaler values for these frequencies are 0, 1, and 2.

Table 77. USB SFR memory map

SFR Addr	Reg Name	Bit Register Name								Reset value	Comments
		7	6	5	4	3	2	1	0		
E1	USCL									00	8-bit Prescaler for USB logic
E6	UDT1	UDT1.7	UDT1.6	UDT1.5	UDT1.4	UDT1.3	UDT1.2	UDT1.1	UDT1.0	00	USB Endpt1 Data Xmit
E7	UDT0	UDT0.7	UDT0.6	UDT0.5	UDT0.4	UDT0.3	UDT0.2	UDT0.1	UDT0.0	00	USB Endpt0 Data Xmit
E8	UISTA	SUSPND	—	RSTF	TXD0F	RXD0F	RXD1F	EOPF	RESUMF	00	USB Interrupt Status
E9	UIEN	SUSPNDI E	RSTE	RSTFIE	TXD0IE	RXD0IE	TXD1IE	EOPIE	RESUMI E	00	USB Interrupt Enable
EA	UCON0	TSEQ0	STALL0	TX0E	RX0E	TP0SIZ3	TP0SIZ2	TP0SIZ1	TP0SIZ0	00	USB Endpt0 Xmit Control
EB	UCON1	TSEQ1	EP12SE L	—	FRESU M	TP1SIZ3	TP1SIZ2	TP1SIZ1	TP1SIZ0	00	USB Endpt1 Xmit Control
EC	UCON2	—	—	—	SOUT	EP2E	EP1E	STALL2	STALL1	00	USB Control Register
ED	USTA	RSEQ	SETUP	IN	OUT	RP0SIZ3	RP0SIZ2	RP0SIZ1	RP0SIZ0	00	USB Endpt0 Status
EE	UADR	USBEN	UADD6	UADD5	UADD4	UADD3	UADD2	UADD1	UADD0	00	USB Address Register
EF	UDR0	UDR0.7	UDR0.6	UDR0.5	UDR0.4	UDR0.3	UDR0.2	UDR0.1	UDR0.0	00	USB Endpt0 Data Recv

## 16.2 Transceiver

### 16.2.1 USB physical layer characteristics

The following section describes the UPSD321xx devices compliance to the Chapter 7 Electrical section of the USB Specification, Revision 1.1. The section contains all signaling, and physical layer specifications necessary to describe a low speed USB function.

### 16.2.2 Low speed driver characteristics

The UPSD321xx devices use a differential output driver to drive the Low Speed USB data signal onto the USB cable. The output swings between the differential high and low state are well balanced to minimize signal skew. The slew rate control on the driver minimizes the radiated noise and cross talk on the USB cable. The driver's outputs support three-state operation to achieve bi-directional half duplex operation. The UPSD321xx devices driver tolerates a voltage on the signal pins of -0.5 V to 3.6 V with respect to local ground reference without damage. The driver tolerates this voltage for 10.0 $\mu$ s while the driver is active and driving, and tolerates this condition indefinitely when the driver is in its high impedance state.

A low speed USB connection is made through an unshielded, untwisted wire cable a maximum of 3 meters in length. The rise and fall time of the signals on this cable are well controlled to reduce RFI emissions while limiting delays, signaling skews and distortions. The UPSD321xx devices driver reaches the specified static signal levels with smooth rise and fall times, resulting in segments between low speed devices and the ports to which they are connected.

**Figure 39. Low speed driver signal waveforms**

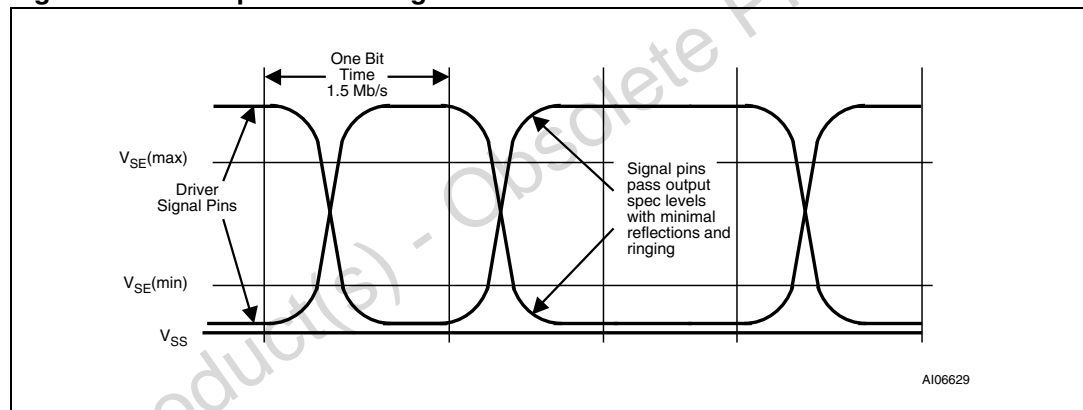

### 16.3 Receiver characteristics

UPSD321xx devices have a differential input receiver which is able to accept the USB data signal. The receiver features an input sensitivity of at least 200 mV when both differential data inputs are in the range of at least 0.8 V to 2.5 V with respect to its local ground reference. This is the common mode range, as shown in [Figure 40](#). The receiver tolerates static input voltages between -0.5 V to 3.8 V with respect to its local ground reference without damage. In addition to the differential receiver, there is a single-ended receiver for each of the two data lines. The single-ended receivers have a switching threshold between 0.8 V and 2.0 V (TTL inputs).

Figure 40. Differential input sensitivity over entire common mode range

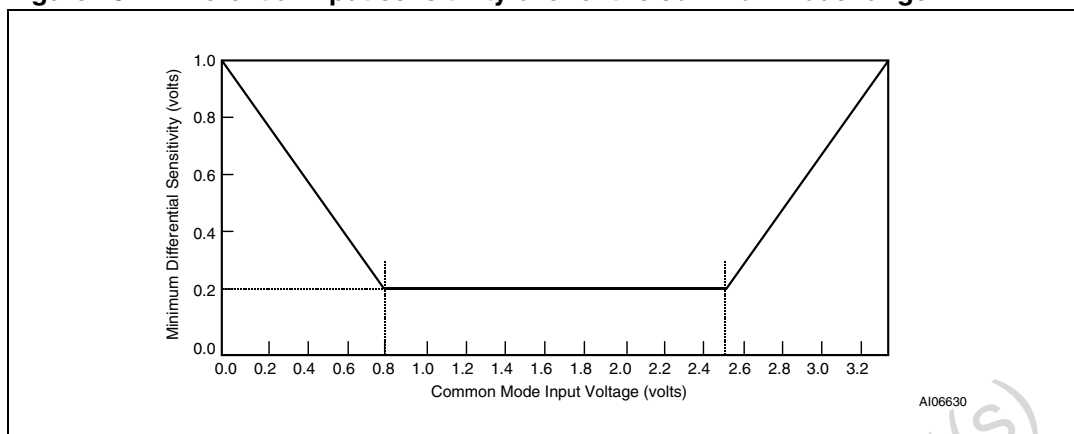

### 16.4 External USB pull-up resistor

The USB system specifies a pull-up resistor on the D- pin for low-speed peripherals. The USB Spec 1.1 describes a 1.5 kΩ pull-up resistor to a 3.3 V supply. An approved alternative method is a 7.5 kΩ pull-up to the USB V<sub>CC</sub> supply. This alternative is defined for low-speed devices with an integrated cable. The chip is specified for the 7.5 kΩ pull-up. This eliminates the need for an external 3.3 V regulator, or for a pin dedicated to providing a 3.3 V output from the chip.

Figure 41. USB data signal timing and voltage levels

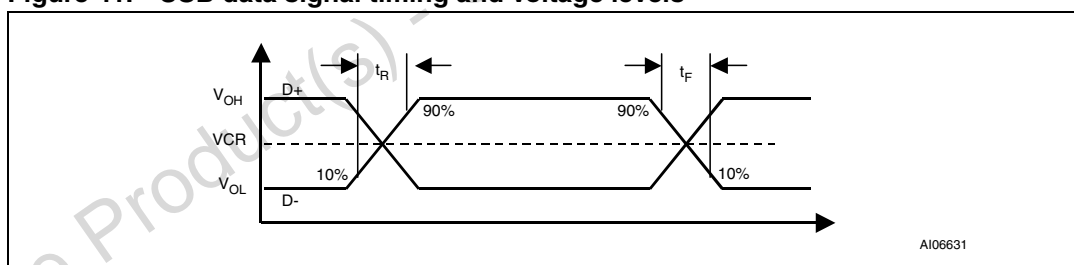

Figure 42. Receiver jitter tolerance

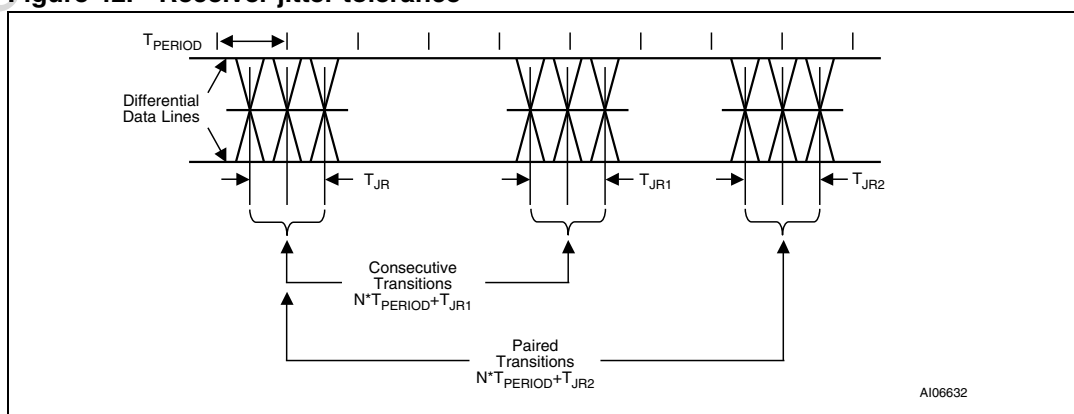



Figure 43. Differential to EOP transition skew and EOP width

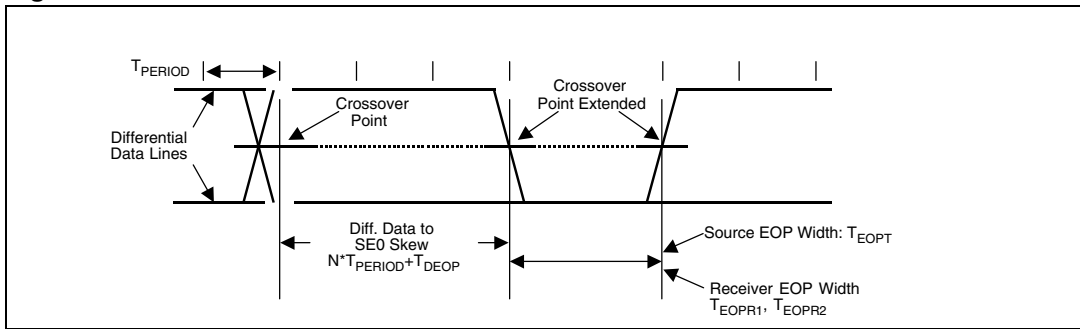

Figure 44. Differential data jitter

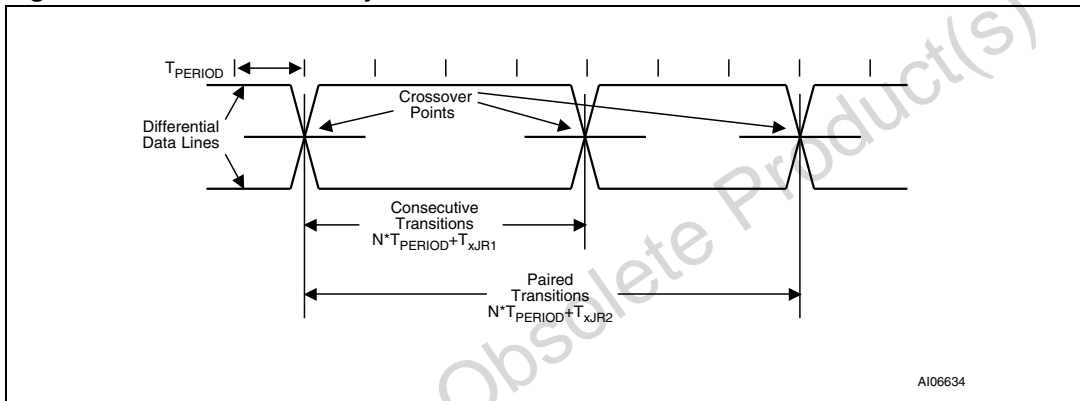

Table 78. Transceiver DC characteristics

Symb	Parameter	Test Conditions <sup>(1)</sup>	Min	Max	Unit
$V_{OH}$	Static Output High	15 k $\Omega$ $\pm$ 5% to GND <sup>(2,3)</sup>	2.8	3.6	V
$V_{OL}$	Static Output Low	Notes 2, 3	—	0.3	V
$V_{DI}$	Differential Input Sensitivity	$ D+ - D- $ , Figure 42	0.2	—	V
$V_{CM}$	Differential Input Common mode	Figure 42	0.8	2.5	V
$V_{SE}$	Single Ended Receiver Threshold	—	0.8	2.0	V
$C_{IN}$	Transceiver Capacitance	—	—	20	pF
$I_{IO}$	Data Line (D+, D-) Leakage	0 < (D+, D-) < 3.3	-10	10	$\mu$ A
$R_{PU}$	External Bus Pull-up Resistance, D-	7.5 k $\Omega$ $\pm$ 2% to $V_{CC}$	7.35	7.65	k $\Omega$
$R_{PD}$	External Bus Pull-down Resistance	15 k $\Omega$ $\pm$ 5%	14.25	15.75	k $\Omega$

- $V_{CC} = 5\text{ V} \pm 10\%$ ;  $V_{SS} = 0\text{ V}$ ;  $T_A = 0\text{ to }70^\circ\text{C}$ .
- Level guaranteed for range of  $V_{CC} = 4.5\text{ V to }5.5\text{ V}$ .
- With  $R_{PU}$ , external idle resistor, 7.5 k $\Omega$   $\pm$  2%, D- to  $V_{CC}$ .

Table 79. Transceiver AC characteristics

Symb	Parameter	Test Conditions <sup>(1)</sup>	Min	Max	Unit
tDRATE	Low Speed Data Rate	Ave. bit rate (1.5Mb/s $\pm$ 1.5%)	1.4775	1.5225	Mbit/s
tDJR1	Receiver Data Jitter Tolerance	To next transition, <i>Figure 42</i> <sup>(5)</sup>	-75	75	ns
tDJR2	Differential Input Sensitivity	For paired transition, <i>Figure 42</i> <sup>(5)</sup>	-45	45	ns
tDEOP	Differential to EOP Transition Skew	<i>Figure 43</i> <sup>(5)</sup>	-40	100	ns
tEOPR1	EOP Width at Receiver	Rejects as EOP <sup>(5,6)</sup>	165	—	ns
tEOPR2	EOP Width at Receiver	Accepts as EOP <sup>(5)</sup>	675	—	ns
tEOPT	Source EOP Width	—	-1.25	1.50	$\mu$ s
tUDJ1	Differential Driver Jitter	To next transition, <i>Figure 44</i>	-95	95	ns
tUDJ2	Differential Driver Jitter	To paired transition, <i>Figure 44</i>	-150	150	ns
tR	USB Data Transition Rise Time	Notes 2, 3, 4	75	300	ns
tF	USB Data Transition Fall Time	Notes 2, 3, 4	75	300	ns
tRFM	Rise/Fall Time Matching	$t_R / t_F$	80	120	%
V <sub>CRS</sub>	Output Signal Crossover Voltage	—	1.3	2.0	V

1.  $V_{CC} = 5\text{ V} \pm 10\%$ ;  $V_{SS} = 0\text{ V}$ ;  $T_A = 0\text{ to }70^\circ\text{C}$ .
2. Level guaranteed for range of  $V_{CC} = 4.5\text{ V to }5.5\text{ V}$ .
3. With RPU, external idle resistor,  $7.5\text{k}\pm 2\%$ , D- to  $V_{CC}$ .
4.  $C_L$  of 50 pF (75 ns) to 350 pF (300 ns).
5. Measured at crossover point of differential data signals.
6. USB specification indicates 330 ns.

## 17 PSD module

The PSD module provides configurable Program and Data memories to the 8032 CPU core (MCU). In addition, it has its own set of I/O ports and a PLD with 16 macrocells for general logic implementation.

Ports A,B,C, and D are general purpose programmable I/O ports that have a port architecture which is different from the I/O ports in the MCU module.

The PSD module communicates with the MCU module through the internal address, data bus (A0-A15, D0-D7) and control signals ( $\overline{RD}$ ,  $\overline{WR}$ ,  $\overline{PSEN}$ , ALE,  $\overline{RESET}$ ). The user defines the Decoding PLD in the PSDsoft Development Tool and can map the resources in the PSD module to any program or data address space. [Figure 45](#) shows the functional blocks in the PSD module.

### 17.1 Functional overview

- 512 Kbit Flash memory. This is the main Flash memory. It is divided into four equal-sized blocks (16 Kbytes each) that can be accessed with user-specified addresses.
- Secondary 128 Kbit Flash boot memory. It is divided into two equal-sized blocks (8 Kbytes each) that can be accessed with user-specified addresses. This secondary memory brings the ability to execute code and update the main Flash *concurrently*.
- 16 Kbit SRAM.
- CPLD with 16 Output Micro Cells (OMCs) and up to 20 Input Micro Cells (IMCs). The CPLD may be used to efficiently implement a variety of logic functions for internal and external control. Examples include state machines, loadable shift registers, and loadable counters.
- Decode PLD (DPLD) that decodes address for selection of memory blocks in the PSD module.
- Configurable I/O ports (Port A,B,C and D) that can be used for the following functions:
  - MCU I/Os
  - PLD I/Os
  - Latched MCU address output
  - Special function I/Os
  - I/O ports may be configured as open-drain outputs
- Built-in JTAG compliant serial port allows full-chip In-System Programmability (ISP). With it, you can program a blank device or reprogram a device in the factory or the field.
- Internal page register that can be used to expand the 8032 MCU module address space by a factor of 256.
- Internal programmable Power Management Unit (PMU) that supports a low-power mode called Power-down mode. The PMU can automatically detect a lack of the 8032 CPU core activity and put the PSD module into Power-down mode.
- Erase/WRITE cycles:
  - Flash memory - 100,000 minimum
  - PLD - 1,000 minimum
  - Data Retention: 15 year minimum (for Main Flash memory, Boot, PLD and Configuration bits)

Figure 45. UPSD321xx PSD module block diagram

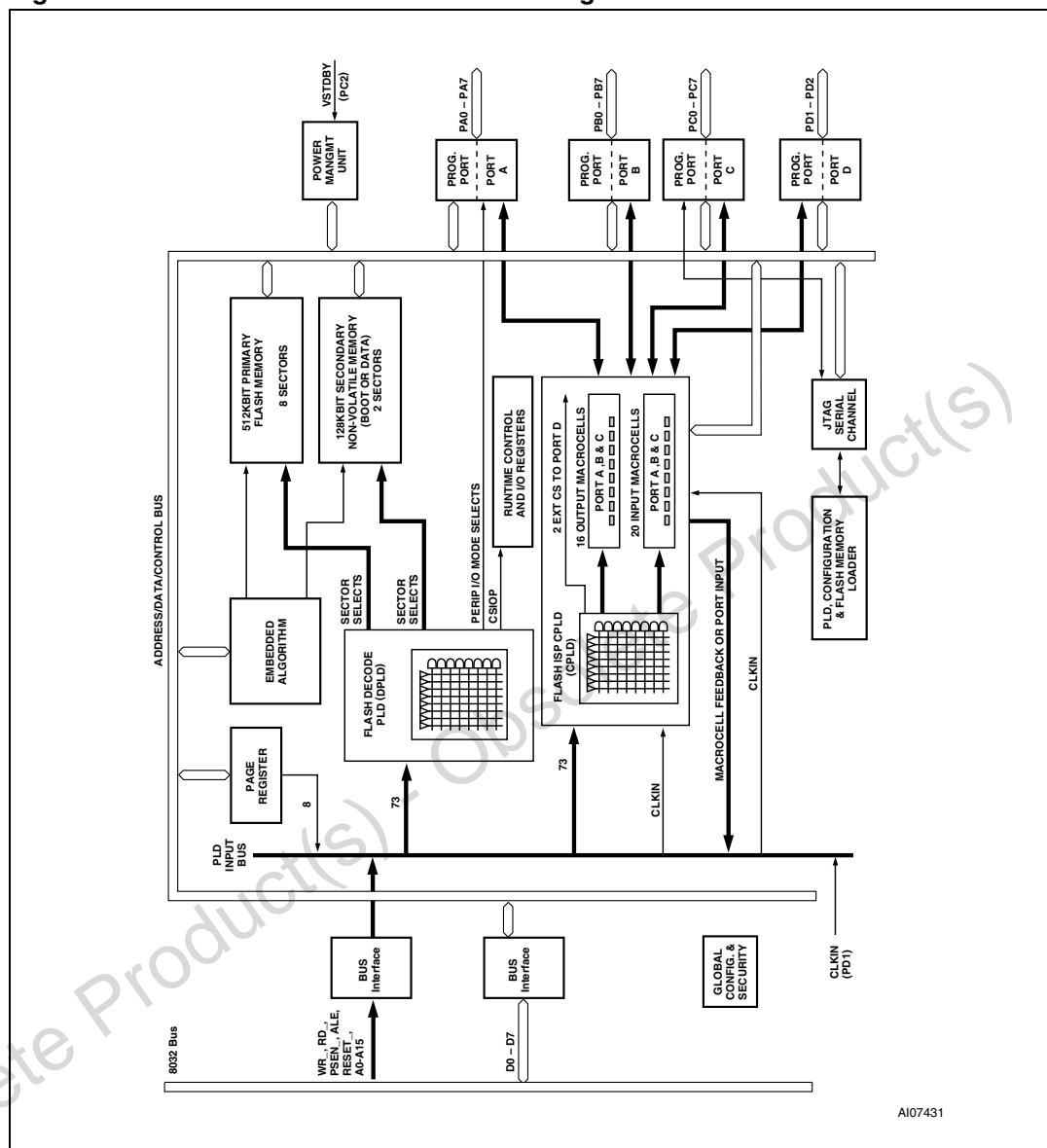

A107431

## 17.2 In-system programming (ISP)

Using the JTAG signals on Port C, the entire PSD module device can be programmed or erased without the use of the MCU. The primary Flash memory can also be programmed in-system by the MCU executing the programming algorithms out of the secondary memory, or SRAM. The secondary memory can be programmed the same way by executing out of the primary Flash memory. The PLD or other PSD module configuration blocks can be programmed through the JTAG port or a device programmer. Table [Table 80](#) indicates which programming methods can program different functional blocks of the PSD module.

**Table 80. Methods of programming different functional blocks of the PSD module**

Functional Block	JTAG programming	Device programmer	IAP
Primary Flash memory	Yes	Yes	Yes
Secondary Flash memory	Yes	Yes	Yes
PLD array (DPLD and CPLD)	Yes	Yes	No
PSD module configuration	Yes	Yes	No

Obsolete Product(s) - Obsolete Product(s)

# 18 Development system

UPSD321xx devices are supported by PSDsoft, a Windows-based software development tool (Windows-95, Windows-98, Windows-NT). A PSD module design is quickly and easily produced in a point and click environment. The designer does not need to enter Hardware Description Language (HDL) equations, unless desired, to define PSD module pin functions and memory map information. The general design flow is shown in [Figure 46](#). PSDsoft is available from our web site (the address is given on the back page of this data sheet) or other distribution channels.

PSDsoft directly supports a low cost device programmer from ST: FlashLINK (JTAG). The programmer may be purchased through your local distributor/representative. UPSD321xx devices are also supported by third party device programmers. See our web site for the current list.

**Figure 46. PSDsoft express development tool**

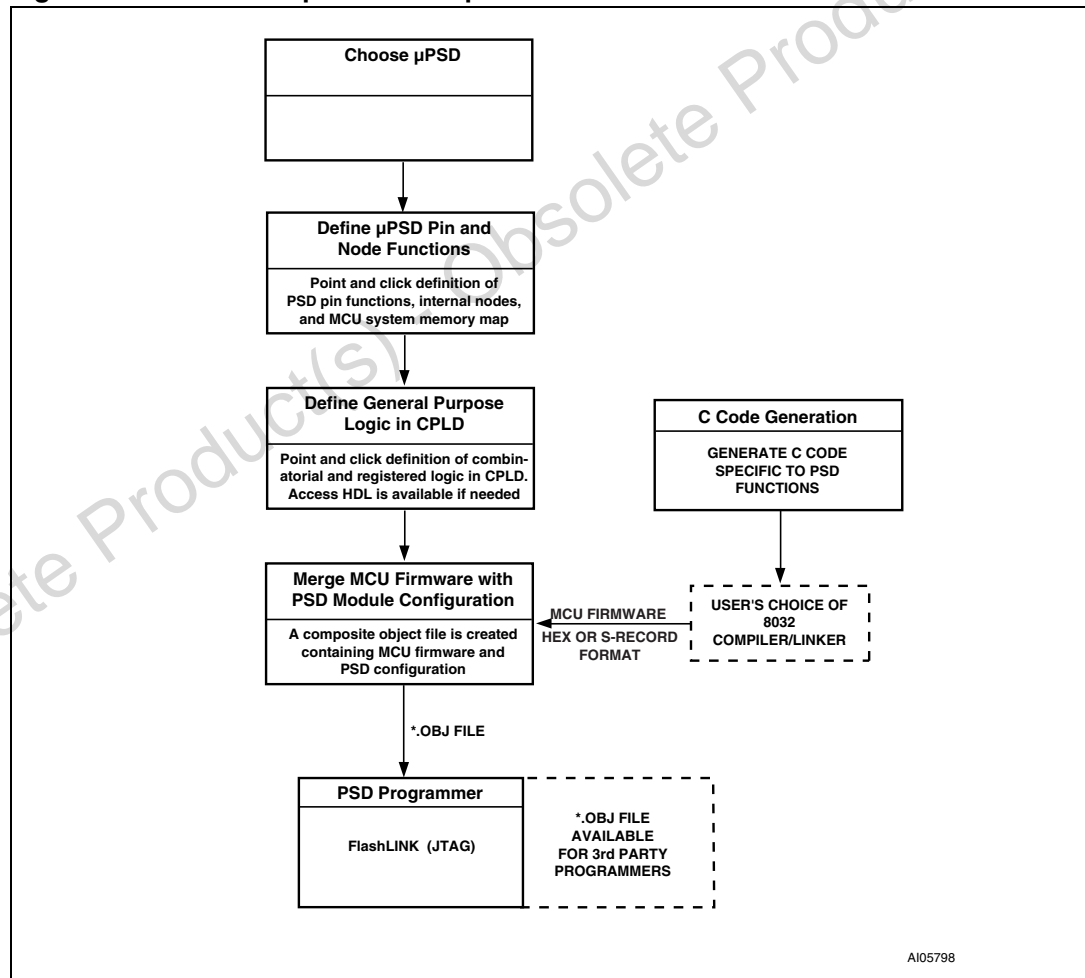

AI05798

## 19 PSD module register description and address offset

*Table 81* shows the offset addresses to the PSD module registers relative to the CSIOP base address. The CSIOP space is the 256 bytes of address that is allocated by the user to the internal PSD module registers. *Table 81* provides brief descriptions of the registers in CSIOP space. The following section gives a more detailed description.

**Table 81. Register address offset**

Register Name	Port A	Port B	Port C	Port D	Other <sup>(1)</sup>	Description
Data In	00	01	10	11		Reads Port pin as input, MCU I/O Input mode
Control	02	03				Selects mode between MCU I/O or Address Out
Data Out	04	05	12	13		Stores data for output to Port pins, MCU I/O Output mode
Direction	06	07	14	15		Configures Port pin as input or output
Drive Select	08	09	16	17		Configures Port pins as either CMOS or Open Drain on some pins, while selecting high slew rate on other pins.
Input Macrocell	0A	0B	18			Reads Input Macrocells
Enable Out	0C	0D	1A	1B		Reads the status of the output enable to the I/O Port driver
Output Macrocells AB	20	20				READ – reads output of macrocells AB WRITE – loads macrocell flip-flops
Output Macrocells BC		21	21			READ – reads output of macrocells BC WRITE – loads macrocell flip-flops
Mask Macrocells AB	22	22				Blocks writing to the Output Macrocells AB
Mask Macrocells BC		23	23			Blocks writing to the Output Macrocells BC
Primary Flash Protection					C0	Read-only – Primary Flash Sector Protection
Secondary Flash memory Protection					C2	Read-only – PSD module Security and Secondary Flash memory Sector Protection
PMMR0					B0	Power Management Register 0
PMMR2					B4	Power Management Register 2
Page					E0	Page Register
VM					E2	Places PSD module memory areas in Program and/or Data space on an individual basis.

1. Other registers that are not part of the I/O ports.

## 20 PSD module detailed operation

As shown in [Figure 14](#), the PSD module consists of five major types of functional blocks:

- Memory blocks
- PLD blocks
- I/O Ports
- Power Management Unit (PMU)
- JTAG Interface

The functions of each block are described in the following sections. Many of the blocks perform multiple functions, and are user configurable.

Obsolete Product(s) - Obsolete Product(s)



## 21 Memory blocks

The PSD module has the following memory blocks:

- Primary Flash memory
- Secondary Flash memory
- SRAM

The Memory Select signals for these blocks originate from the Decode PLD (DPLD) and are user-defined in PSDsoft Express.

### 21.1 Primary Flash memory and secondary Flash memory description

The primary Flash memory is divided evenly into four equal sectors. The secondary Flash memory is divided into two equal sectors. Each sector of either memory block can be separately protected from Program and Erase cycles.

Flash memory may be erased on a sector-by-sector basis. Flash sector erasure may be suspended while data is read from other sectors of the block and then resumed after reading.

During a Program or Erase cycle in Flash memory, the status can be output on Ready/ $\overline{\text{Busy}}$  (PC3). This pin is set up using PSDsoft Express Configuration.

### 21.2 Memory block select signals

The DPLD generates the Select signals for all the internal memory blocks (see [Section 22: PLDs](#)). Each of the four sectors of the primary Flash memory has a Select signal (FS0-FS3) which can contain up to three product terms. Each of the two sectors of the secondary Flash memory has a Select signal (CSBOOT0-CSBOOT1) which can contain up to three product terms. Having three product terms for each Select signal allows a given sector to be mapped in Program or Data space.

#### 21.2.1 Ready/ $\overline{\text{Busy}}$ (PC3)

This signal can be used to output the Ready/ $\overline{\text{Busy}}$  status of the Flash memory. The output on Ready/ $\overline{\text{Busy}}$  (PC3) is a '0' (Busy) when Flash memory is being written to, or when Flash memory is being erased. The output is a '1' (Ready) when no WRITE or Erase cycle is in progress.

#### 21.2.2 Memory operation

The primary Flash memory and secondary Flash memory are addressed through the MCU Bus. The MCU can access these memories in one of two ways:

- The MCU can execute a typical bus WRITE or READ *operation*.
- The MCU can execute a specific Flash memory instruction that consists of several WRITE and READ operations. This involves writing specific data patterns to special addresses within the Flash memory to invoke an embedded algorithm. These instructions are summarized in [Table 82](#).

Typically, the MCU can read Flash memory using READ operations, just as it would read a ROM device. However, Flash memory can only be altered using specific Erase and Program instructions. For example, the MCU cannot write a single byte directly to Flash memory as it would write a byte to RAM. To program a byte into Flash memory, the MCU must execute a Program instruction, then test the status of the Program cycle. This status test is achieved by a READ operation or polling Ready/Busy (PC3).

## 21.3 Instructions

An instruction consists of a sequence of specific operations. Each received byte is sequentially decoded by the PSD module and not executed as a standard WRITE operation. The instruction is executed when the correct number of bytes are properly received and the time between two consecutive bytes is shorter than the time-out period. Some instructions are structured to include READ operations after the initial WRITE operations.

The instruction must be followed exactly. Any invalid combination of instruction bytes or time-out between two consecutive bytes while addressing Flash memory resets the device logic into READ mode (Flash memory is read like a ROM device).

The Flash memory supports the instructions summarized in [Table 82](#):

- Erase memory by chip or sector
- Suspend or resume sector erase
- Program a Byte
- RESET to READ mode
- Read Sector Protection Status

These instructions are detailed in [Table 82](#). For efficient decoding of the instructions, the first two bytes of an instruction are the coded cycles and are followed by an instruction byte or confirmation byte. The coded cycles consist of writing the data AAh to address X555h during the first cycle and data 55h to address XAAAh during the second cycle. Address signals A15-A12 are Don't Care during the instruction WRITE cycles. However, the appropriate Sector Select (FS0-FS3 or CSBOOT0-CSBOOT1) must be selected.

The primary and secondary Flash memories have the same instruction set (except for Read Primary Flash Identifier). The Sector Select signals determine which Flash memory is to receive and execute the instruction. The primary Flash memory is selected if any one of Sector Select (FS0-FS3) is High, and the secondary Flash memory is selected if any one of Sector Select (CSBOOT0-CSBOOT1) is High.

**Table 82. Instructions**

Instruction	FS0-FS3 or CSBOOT0-CSBOOT1	Cycle 1	Cycle 2	Cycle 3	Cycle 4	Cycle 5	Cycle 6	Cycle 7
READ <sup>(5)</sup>	1	"Read" RD @ RA						
READ Sector Protection <sup>(6,8,13)</sup>	1	AAh@ X555h	55h@ XAAAh	90h@ X555h	Read status @ XX02h			
Program a Flash Byte <sup>(13)</sup>	1	AAh@ X555h	55h@ XAAAh	A0h@ X555h	PD@ PA			

**Table 82. Instructions (continued)**

Instruction	FS0-FS3 or CSBOOT0-CSBOOT1	Cycle 1	Cycle 2	Cycle 3	Cycle 4	Cycle 5	Cycle 6	Cycle 7
Flash Sector Erase <sup>(7,13)</sup>	1	AAh@ X555h	55h@ XAAAh	80h@ X555h	AAh@ X555h	55h@ XAAAh	30h@ SA	30h <sup>7</sup> @ next SA
Flash Bulk Erase <sup>(13)</sup>	1	AAh@ X555h	55h@ XAAAh	80h@ X555h	AAh@ X555h	55h@ XAAAh	10h@ X555h	
Suspend Sector Erase <sup>(11)</sup>	1	B0h@ XXXXh						
Resume Sector Erase <sup>(12)</sup>	1	30h@ XXXXh						
RESET <sup>(6)</sup>	1	F0h@ XXXXh						

1. All bus cycles are WRITE bus cycles, except the ones with the “Read” label
2. All values are in hexadecimal.
3. X = Don’t care. Addresses of the form XXXXh, in this table, must be even addresses
4. RA = Address of the memory location to be read
5. RD = Data READ from location RA during the READ cycle
6. PA = Address of the memory location to be programmed. Addresses are latched on the falling edge of WRITE Strobe (WR, CNTL0).
7. PA is an even address for PSD in Word Programming mode.
8. PD = Data word to be programmed at location PA. Data is latched on the rising edge of WRITE Strobe (WR, CNTL0)
9. SA = Address of the sector to be erased or verified. The Sector Select (FS0-FS3 or CSBOOT0-CSBOOT1) of the sector to be erased, or verified, must be Active (High).
10. Sector Select (FS0-FS3 or CSBOOT0-CSBOOT1) signals are active High, and are defined in PSDsoft Express.
11. Only address Bits A11-A0 are used in instruction decoding.
12. No Unlock or instruction cycles are required when the device is in the READ mode
13. The RESET instruction is required to return to the READ mode after reading the Sector Protection Status, or if the Error flag bit (DQ5) goes High.
14. Additional sectors to be erased must be written at the end of the Sector Erase instruction within 80µs.
15. The data is 00h for an unprotected sector, and 01h for a protected sector. In the fourth cycle, the Sector Select is active, and (A1,A0)=(1,0)
16. The system may perform READ and Program cycles in non-erasing sectors, read the Flash ID or read the Sector Protection Status when in the Suspend Sector Erase mode. The Suspend Sector Erase instruction is valid only during a Sector Erase cycle.
17. The Resume Sector Erase instruction is valid only during the Suspend Sector Erase mode.
18. The MCU cannot invoke these instructions while executing code from the same Flash memory as that for which the instruction is intended. The MCU must retrieve, for example, the code from the secondary Flash memory when reading the Sector Protection Status of the primary Flash memory.

## 21.4 Power-down instruction and Power-up mode

### 21.4.1 Power-up mode

The PSD module internal logic is reset upon Power-up to the READ mode. Sector Select (FS0-FS3 and CSBOOT0-CSBOOT1) must be held Low, and WRITE Strobe (WR, CNTL0) High, during Power-up for maximum security of the data contents and to remove the

possibility of a byte being written on the first edge of WRITE Strobe ( $\overline{WR}$ , CNTL0). Any WRITE cycle initiation is locked when  $V_{CC}$  is below  $V_{LKO}$ .

## 21.5 Read

Under typical conditions, the MCU may read the primary Flash memory or the secondary Flash memory using READ operations just as it would a ROM or RAM device. Alternately, the MCU may use READ operations to obtain status information about a Program or Erase cycle that is currently in progress. Lastly, the MCU may use instructions to read special data from these memory blocks. The following sections describe these READ functions.

### 21.5.1 Read memory contents

Primary Flash memory and secondary Flash memory are placed in the READ mode after Power-up, chip reset, or a Reset Flash instruction (see [Table 82](#)). The MCU can read the memory contents of the primary Flash memory or the secondary Flash memory by using READ operations any time the READ operation is not part of an instruction.

### 21.5.2 Read memory sector protection status

The primary Flash memory Sector Protection Status is read with an instruction composed of 4 operations: 3 specific WRITE operations and a READ operation (see [Table 82](#)). During the READ operation, address Bits A6, A1, and A0 must be '0,' '1,' and '0,' respectively, while Sector Select (FS0-FS3 or CSBOOT0-CSBOOT1) designates the Flash memory sector whose protection has to be verified. The READ operation produces 01h if the Flash memory sector is protected, or 00h if the sector is not protected.

The sector protection status for all NVM blocks (primary Flash memory or secondary Flash memory) can also be read by the MCU accessing the Flash Protection registers in PSD I/O space. See [Section 21.8.1: Flash memory sector protect](#) for register definitions.

### 21.5.3 Reading the Erase/Program status bits

The Flash memory provides several status bits to be used by the MCU to confirm the completion of an Erase or Program cycle of Flash memory. These status bits minimize the time that the MCU spends performing these tasks and are defined in [Table 83](#). The status bits can be read as many times as needed.

For Flash memory, the MCU can perform a READ operation to obtain these status bits while an Erase or Program instruction is being executed by the embedded algorithm. See [Section 21.6: Programming Flash memory](#), for details.

### 21.5.4 Data polling flag (DQ7)

When erasing or programming in Flash memory, the Data Polling flag bit (DQ7) outputs the complement of the bit being entered for programming/writing on the DQ7 Bit. Once the

Program instruction or the WRITE operation is completed, the true logic value is read on the Data Polling flag bit (DQ7) (in a READ operation).

- Data Polling is effective after the fourth WRITE pulse (for a Program instruction) or after the sixth WRITE pulse (for an Erase instruction). It must be performed at the address being programmed or at an address within the Flash memory sector being erased.
- During an Erase cycle, the Data Polling flag bit (DQ7) outputs a '0.' After completion of the cycle, the Data Polling flag bit (DQ7) outputs the last bit programmed (it is a '1' after erasing).
- If the byte to be programmed is in a protected Flash memory sector, the instruction is ignored.
- If all the Flash memory sectors to be erased are protected, the Data Polling flag bit (DQ7) is reset to '0' for about 100µs, and then returns to the previous addressed byte. No erasure is performed.

### 21.5.5 Toggle flag (DQ6)

The Flash memory offers another way for determining when the Program cycle is completed. During the internal WRITE operation and when either the FS0-FS3 or CSBOOT0-CSBOOT1 is true, the Toggle flag bit (DQ6) toggles from '0' to '1' and '1' to '0' on subsequent attempts to read any byte of the memory.

When the internal cycle is complete, the toggling stops and the data READ on the Data Bus D0-D7 is the addressed memory byte. The device is now accessible for a new READ or WRITE operation. The cycle is finished when two successive Reads yield the same output data.

- The Toggle flag bit (DQ6) is effective after the fourth WRITE pulse (for a Program instruction) or after the sixth WRITE pulse (for an Erase instruction).
- If the byte to be programmed belongs to a protected Flash memory sector, the instruction is ignored.
- If all the Flash memory sectors selected for erasure are protected, the Toggle flag bit (DQ6) toggles to '0' for about 100µs and then returns to the previous addressed byte.

### 21.5.6 Error flag (DQ5)

During a normal Program or Erase cycle, the Error flag bit (DQ5) is to '0.' This bit is set to '1' when there is a failure during Flash memory Byte Program, Sector Erase, or Bulk Erase cycle.

In the case of Flash memory programming, the Error flag bit (DQ5) indicates the attempt to program a Flash memory bit from the programmed state, '0', to the erased state, '1,' which is not valid. The Error flag bit (DQ5) may also indicate a Time-out condition while attempting to program a byte.

In case of an error in a Flash memory Sector Erase or Byte Program cycle, the Flash memory sector in which the error occurred or to which the programmed byte belongs must no longer be used. Other Flash memory sectors may still be used. The Error Flag bit (DQ5) is reset after a Reset Flash instruction.

### 21.5.7 Erase time-out flag (DQ3)

The Erase Time-out Flag bit (DQ3) reflects the time-out period allowed between two consecutive Sector Erase instructions. The Erase Time-out Flag bit (DQ3) is reset to '0' after

a Sector Erase cycle for a time period of  $100\mu\text{s} + 20\%$  unless an additional Sector Erase instruction is decoded. After this time period, or when the additional Sector Erase instruction is decoded, the Erase Time-out Flag bit (DQ3) is set to '1'.

**Table 83. Status bit**

Functional Block	FS0-FS3/ CSBOOT0- CSBOOT1	DQ7	DQ6	DQ5	DQ4	DQ3	DQ2	DQ1	DQ0
Flash Memory	$V_{IH}$	Data Polling	Toggle Flag	Error Flag	X	Erase Time-out	X	X	X

1. X = Not guaranteed value, can be read either '1' or '0.'
2. DQ7-DQ0 represent the Data Bus bits, D7-D0.
3. FS0-FS3 and CSBOOT0-CSBOOT1 are active High.

## 21.6 Programming Flash memory

Flash memory must be erased prior to being programmed. A byte of Flash memory is erased to all '1's (FFh), and is programmed by setting selected bits to '0'. The MCU may erase Flash memory all at once or by-sector, but not byte-by-byte. However, the MCU may program Flash memory byte-by-byte.

The primary and secondary Flash memories require the MCU to send an instruction to program a byte or to erase sectors (see [Table 82](#)).

Once the MCU issues a Flash memory Program or Erase instruction, it must check for the status bits for completion. The embedded algorithms that are invoked support several means to provide status to the MCU. Status may be checked using any of three methods: Data Polling, Data Toggle, or Ready/Busy (PC3).

### 21.6.1 Data Polling

Polling on the Data Polling Flag bit (DQ7) is a method of checking whether a Program or Erase cycle is in progress or has completed. [Figure 47](#) shows the Data Polling algorithm.

When the MCU issues a Program instruction, the embedded algorithm begins. The MCU then reads the location of the byte to be programmed in Flash memory to check status. The Data Polling Flag bit (DQ7) of this location becomes the complement of b7 of the original data byte to be programmed. The MCU continues to poll this location, comparing the Data Polling Flag bit (DQ7) and monitoring the Error Flag bit (DQ5). When the Data Polling Flag bit (DQ7) matches b7 of the original data, and the Error Flag bit (DQ5) remains '0,' the embedded algorithm is complete. If the Error Flag bit (DQ5) is '1,' the MCU should test the Data Polling Flag bit (DQ7) again since the Data Polling Flag bit (DQ7) may have changed simultaneously with the Error Flag bit (DQ5) (see [Figure 47](#)).

The Error Flag bit (DQ5) is set if either an internal time-out occurred while the embedded algorithm attempted to program the byte or if the MCU attempted to program a '1' to a bit that was not erased (not erased is logic '0').

It is suggested (as with all Flash memories) to read the location again after the embedded programming algorithm has completed, to compare the byte that was written to the Flash memory with the byte that was intended to be written.

When using the Data Polling method during an Erase cycle, [Figure 47](#) still applies. However, the Data Polling Flag bit (DQ7) is '0' until the Erase cycle is complete. A '1' on the Error Flag bit (DQ5) indicates a time-out condition on the Erase cycle; a '0' indicates no error. The MCU can read any location within the sector being erased to get the Data Polling Flag bit (DQ7) and the Error Flag bit (DQ5).

PSDsoft Express generates ANSI C code functions which implement these Data Polling algorithms.

**Figure 47. Data polling flowchart**

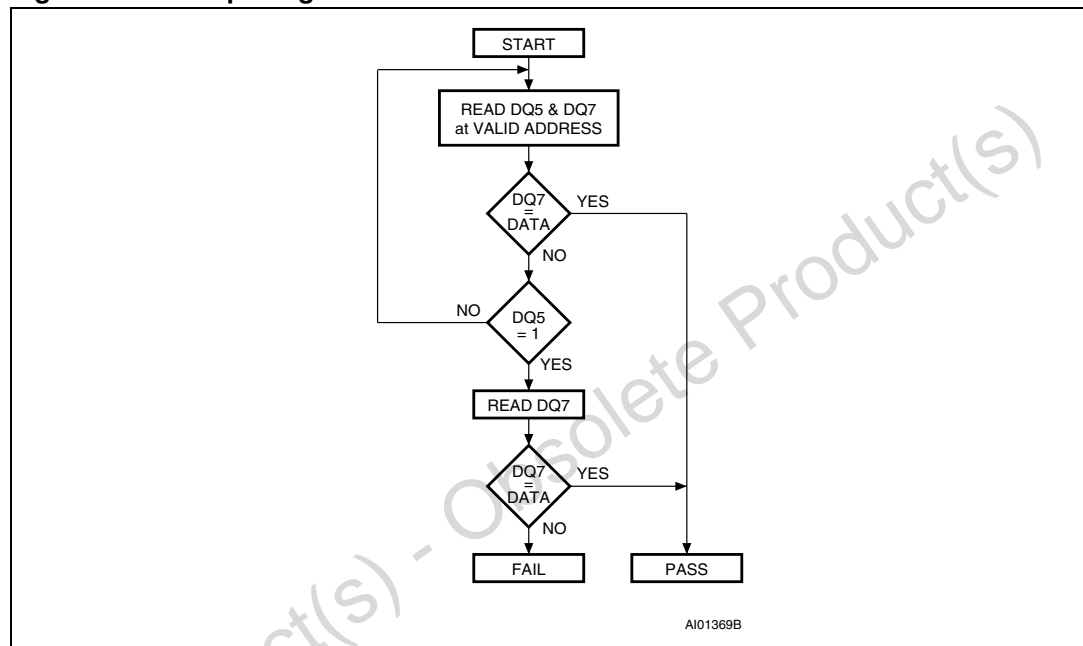

### 21.6.2 Data toggle

Checking the Toggle Flag bit (DQ6) is a method of determining whether a Program or Erase cycle is in progress or has completed. [Figure 48](#) shows the Data Toggle algorithm.

When the MCU issues a Program instruction, the embedded algorithm begins. The MCU then reads the location of the byte to be programmed in Flash memory to check status. The Toggle Flag bit (DQ6) of this location toggles each time the MCU reads this location until the embedded algorithm is complete. The MCU continues to read this location, checking the Toggle Flag bit (DQ6) and monitoring the Error Flag bit (DQ5). When the Toggle Flag bit (DQ6) stops toggling (two consecutive reads yield the same value), and the Error Flag bit (DQ5) remains '0,' the embedded algorithm is complete. If the Error Flag bit (DQ5) is '1,' the MCU should test the Toggle Flag bit (DQ6) again, since the Toggle Flag bit (DQ6) may have changed simultaneously with the Error Flag bit (DQ5) (see [Figure 48](#)).

The Error Flag bit (DQ5) is set if either an internal time-out occurred while the embedded algorithm attempted to program the byte, or if the MCU attempted to program a '1' to a bit that was not erased (not erased is logic '0').

It is suggested (as with all Flash memories) to read the location again after the embedded programming algorithm has completed, to compare the byte that was written to Flash memory with the byte that was intended to be written.

When using the Data Toggle method after an Erase cycle, [Figure 48](#) still applies. the Toggle Flag bit (DQ6) toggles until the Erase cycle is complete. A 1 on the Error Flag bit (DQ5) indicates a time-out condition on the Erase cycle; a '0' indicates no error. The MCU can read any location within the sector being erased to get the Toggle Flag bit (DQ6) and the Error Flag bit (DQ5).

PSDsoft Express generates ANSI C code functions which implement these Data Toggling algorithms.

**Figure 48. Data toggle flowchart**

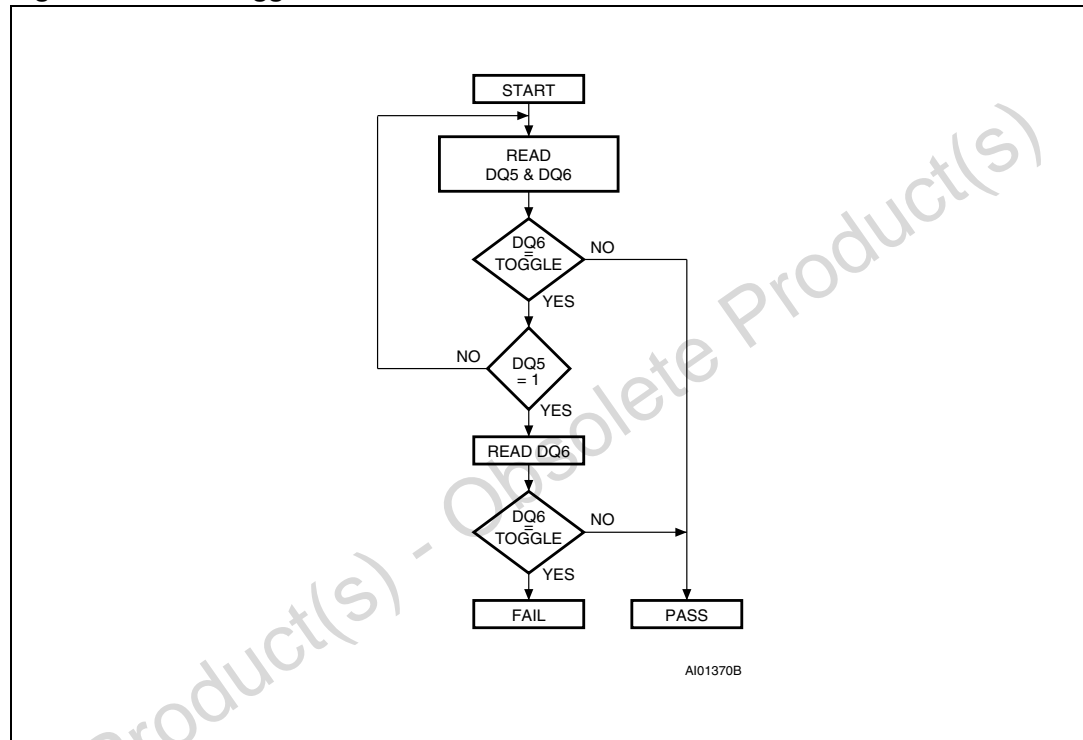

## 21.7 Erasing Flash memory

### 21.7.1 Flash Bulk Erase

The Flash Bulk Erase instruction uses six WRITE operations followed by a READ operation of the status register, as described in [Table 82](#). If any byte of the Bulk Erase instruction is wrong, the Bulk Erase instruction aborts and the device is reset to the READ Flash memory status.

During a Bulk Erase, the memory status may be checked by reading the Error Flag bit (DQ5), the Toggle Flag bit (DQ6), and the Data Polling Flag bit (DQ7), as detailed in [Section 21.6: Programming Flash memory](#). The Error Flag bit (DQ5) returns a '1' if there has been an Erase Failure (maximum number of Erase cycles have been executed).

It is not necessary to program the memory with 00h because the PSD module automatically does this before erasing to 0FFh.

During execution of the Bulk Erase instruction, the Flash memory does not accept any instructions.



### 21.7.2 Flash Sector Erase

The Sector Erase instruction uses six WRITE operations, as described in [Table 82](#). Additional Flash Sector Erase codes and Flash memory sector addresses can be written subsequently to erase other Flash memory sectors in parallel, without further coded cycles, if the additional bytes are transmitted in a shorter time than the time-out period of about 100µs. The input of a new Sector Erase code restarts the time-out period.

The status of the internal timer can be monitored through the level of the Erase Time-out Flag bit (DQ3). If the Erase Time-out Flag bit (DQ3) is '0,' the Sector Erase instruction has been received and the time-out period is counting. If the Erase Time-out Flag bit (DQ3) is '1,' the time-out period has expired and the embedded algorithm is busy erasing the Flash memory sector(s). Before and during Erase time-out, any instruction other than Suspend Sector Erase and Resume Sector Erase instructions abort the cycle that is currently in progress, and reset the device to READ mode.

During a Sector Erase, the memory status may be checked by reading the Error Flag bit (DQ5), the Toggle Flag bit (DQ6), and the Data Polling Flag bit (DQ7), as detailed in [Section 21.6: Programming Flash memory](#).

During execution of the Erase cycle, the Flash memory accepts only RESET and Suspend Sector Erase instructions. Erasure of one Flash memory sector may be suspended, in order to read data from another Flash memory sector, and then resumed.

### 21.7.3 Suspend Sector Erase

When a Sector Erase cycle is in progress, the Suspend Sector Erase instruction can be used to suspend the cycle by writing 0B0h to any address when an appropriate Sector Select (FS0-FS3 or CSBOOT0-CSBOOT1) is High. (See [Table 82](#)). This allows reading of data from another Flash memory sector after the Erase cycle has been suspended. Suspend Sector Erase is accepted only during an Erase cycle and defaults to READ mode. A Suspend Sector Erase instruction executed during an Erase time-out period, in addition to suspending the Erase cycle, terminates the time out period.

The Toggle Flag bit (DQ6) stops toggling when the internal logic is suspended. The status of this bit must be monitored at an address within the Flash memory sector being erased. The Toggle Flag bit (DQ6) stops toggling between 0.1µs and 15µs after the Suspend Sector Erase instruction has been executed. The Flash memory is then automatically set to READ mode.

If an Suspend Sector Erase instruction was executed, the following rules apply:

- Attempting to read from a Flash memory sector that was being erased outputs invalid data.
- Reading from a Flash sector that was *not* being erased is valid.
- The Flash memory *cannot* be programmed, and only responds to Resume Sector Erase and Reset Flash instructions (READ is an operation and is allowed).
- If a Reset Flash instruction is received, data in the Flash memory sector that was being erased is invalid.

### 21.7.4 Resume Sector Erase

If a Suspend Sector Erase instruction was previously executed, the erase cycle may be resumed with this instruction. The Resume Sector Erase instruction consists of writing 030h

to any address while an appropriate Sector Select (FS0-FS3 or CSBOOT0-CSBOOT1) is High. (See [Table 82](#).)

## 21.8 Specific features

### 21.8.1 Flash memory sector protect

Each primary and secondary Flash memory sector can be separately protected against Program and Erase cycles. Sector Protection provides additional data security because it disables all Program or Erase cycles. This mode can be activated through the JTAG Port or a Device Programmer.

Sector protection can be selected for each sector using the PSDsoft Express Configuration program. This automatically protects selected sectors when the device is programmed through the JTAG Port or a Device Programmer. Flash memory sectors can be unprotected to allow updating of their contents using the JTAG Port or a Device Programmer. The MCU can read (but cannot change) the sector protection bits.

Any attempt to program or erase a protected Flash memory sector is ignored by the device. The Verify operation results in a READ of the protected data. This allows a guarantee of the retention of the Protection status.

The sector protection status can be read by the MCU through the Flash memory protection registers (in the CSIOP block). See [Table 84](#) and [Table 85](#).

**Table 84. Sector protection/security bit definition – Flash protection register**

Bit 7	Bit 6	Bit 5	Bit 4	Bit 3	Bit 2	Bit 1	Bit 0
Not used	Not used	Not used	Not used	Sec3_Prot	Sec2_Prot	Sec1_Prot	Sec0_Prot

1. Bit Definitions:  
 Sec<i><i>\_Prot 1 = Primary Flash memory or secondary Flash memory Sector <i> is write-protected.  
 Sec<i><i>\_Prot 0 = Primary Flash memory or secondary Flash memory Sector <i> is not write-protected.

**Table 85. Sector protection/security bit definition – secondary Flash protection register**

Bit 7	Bit 6	Bit 5	Bit 4	Bit 3	Bit 2	Bit 1	Bit 0
Security_Bit	Not used	Not used	Not used	Not used	Not used	Sec1_Prot	Sec0_Prot

1. Bit Definitions:  
 Sec<i><i>\_Prot 1 = Secondary Flash memory Sector <i> is write-protected.  
 Sec<i><i>\_Prot 0 = Secondary Flash memory Sector <i> is not write-protected.  
 Security\_Bit 0 = Security Bit in device has not been set; 1 = Security Bit in device has been set.

### 21.8.2 Reset Flash

The Reset Flash instruction consists of one WRITE cycle (see [Table 82](#)). It can also be optionally preceded by the standard two WRITE decoding cycles (writing AAh to 555h and 55h to AAAh). It must be executed after:

- Reading the Flash Protection Status or Flash ID
- An Error condition has occurred (and the device has set the Error Flag bit (DQ5) to '1' during a Flash memory Program or Erase cycle.

The Reset Flash instruction puts the Flash memory back into normal READ mode. If an Error condition has occurred (and the device has set the Error Flag bit (DQ5) to '1' the Flash memory is put back into normal READ mode within a few milliseconds of the Reset Flash instruction having been issued. The Reset Flash instruction is ignored when it is issued during a Program or Bulk Erase cycle of the Flash memory. The Reset Flash instruction aborts any on-going Sector Erase cycle, and returns the Flash memory to the normal READ mode within a few milliseconds.

## 21.9 SRAM

The SRAM is enabled when SRAM Select (RS0) from the DPLD is High. SRAM Select (RS0) can contain up to two product terms, allowing flexible memory mapping.

## 21.10 Sector Select and SRAM Select

Sector Select (FS0-FS3, CSBOOT0-CSBOOT1) and SRAM Select (RS0) are all outputs of the DPLD. They are setup by writing equations for them in PSDsoft Express. The following rules apply to the equations for these signals:

1. Primary Flash memory and secondary Flash memory Sector Select signals must *not* be larger than the physical sector size.
2. Any primary Flash memory sector must *not* be mapped in the same memory space as another Flash memory sector.
3. A secondary Flash memory sector must *not* be mapped in the same memory space as another secondary Flash memory sector.
4. SRAM, I/O, and Peripheral I/O spaces must *not* overlap.
5. A secondary Flash memory sector *may* overlap a primary Flash memory sector. In case of overlap, priority is given to the secondary Flash memory sector.
6. SRAM, I/O, and Peripheral I/O spaces *may* overlap any other memory sector. Priority is given to the SRAM, I/O, or Peripheral I/O.

### 21.10.1 Example

FS0 is valid when the address is in the range of 8000h to BFFFh, CSBOOT0 is valid from 8000h to 9FFFh, and RS0 is valid from 8000h to 87FFh. Any address in the range of RS0 always accesses the SRAM. Any address in the range of CSBOOT0 greater than 87FFh (and less than 9FFFh) automatically addresses secondary Flash memory segment 0. Any address greater than 9FFFh accesses the primary Flash memory segment 0. You can see that half of the primary Flash memory segment 0 and one-fourth of secondary Flash memory segment 0 cannot be accessed in this example.

*Note:* An equation that defined FS1 to anywhere in the range of 8000h to BFFFh would not be valid.

*Figure 49* shows the priority levels for all memory components. Any component on a higher level can overlap and has priority over any component on a lower level. Components on the same level must *not* overlap. Level one has the highest priority and level 3 has the lowest.

### 21.10.2 Memory Select configuration in Program and Data spaces

The MCU Core has separate address spaces for Program memory and Data memory. Any of the memories within the PSD module can reside in either space or both spaces. This is controlled through manipulation of the VM Register that resides in the CSIOP space.

The VM Register is set using PSDsoft Express to have an initial value. It can subsequently be changed by the MCU so that memory mapping can be changed on-the-fly.

For example, you may wish to have SRAM and primary Flash memory in the Data space at Boot-up, and secondary Flash memory in the Program space at Boot-up, and later swap the primary and secondary Flash memories. This is easily done with the VM Register by using PSDsoft Express Configuration to configure it for Boot-up and having the MCU change it when desired. [Table 86](#) describes the VM Register.

**Figure 49. Priority level of memory and I/O components in the PSD module**

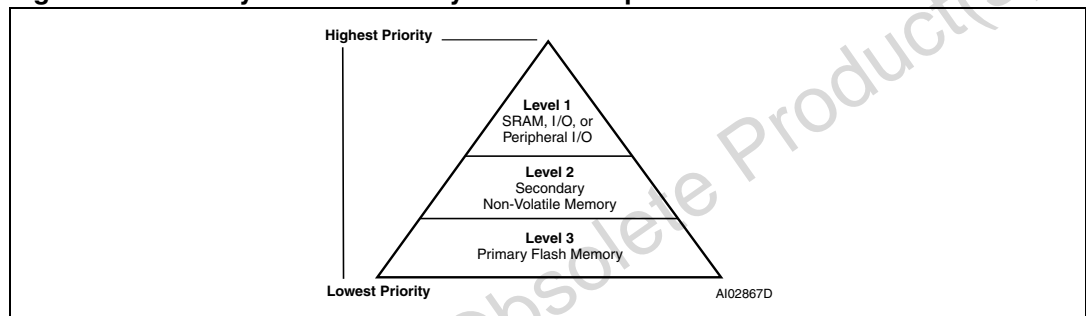

**Table 86. VM register**

Bit 7 PIO_EN	Bit 6	Bit 5	Bit 4 Primary FL_Data	Bit 3 Secondary Data	Bit 2 Primary FL_Cod e	Bit 1 Secondary Code	Bit 0 SRAM_Co de
0 = disable PIO mode	not used	not used	0 = $\overline{RD}$ can't access Flash memory	0 = $\overline{RD}$ can't access Secondary Flash memory	0 = $\overline{PSEN}$ can't access Flash memory	0 = $\overline{PSEN}$ can't access Secondary Flash memory	0 = $\overline{PSEN}$ can't access SRAM
1 = enable PIO mode	not used	not used	1 = $\overline{RD}$ access Flash memory	1 = $\overline{RD}$ access Secondary Flash memory	1 = $\overline{PSEN}$ access Flash memory	1 = $\overline{PSEN}$ access Secondary Flash memory	1 = $\overline{PSEN}$ access SRAM

### 21.10.3 Separate Space mode

Program space is separated from Data space. For example, Program Select Enable ( $\overline{PSEN}$ ) is used to access the program code from the primary Flash memory, while READ Strobe ( $\overline{RD}$ ) is used to access data from the secondary Flash memory, SRAM and I/O Port blocks. This configuration requires the VM Register to be set to 0Ch (see [Figure 50](#)).

### 21.10.4 Combined Space modes

The Program and Data spaces are combined into one memory space that allows the primary Flash memory, secondary Flash memory, and SRAM to be accessed by either Program Select Enable ( $\overline{\text{PSEN}}$ ) or READ Strobe ( $\overline{\text{RD}}$ ). For example, to configure the primary Flash memory in Combined space, Bits b2 and b4 of the VM Register are set to '1' (see [Figure 51](#)).

**Figure 50. Separate Space mode**

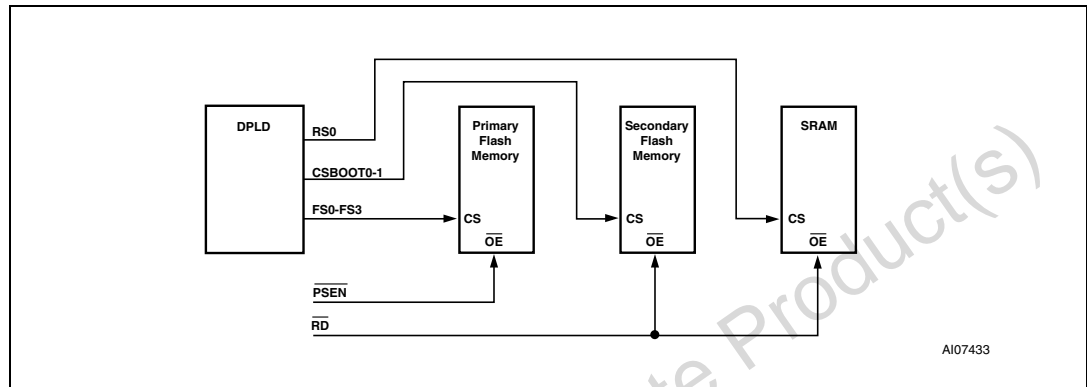

**Figure 51. Combined Space mode**

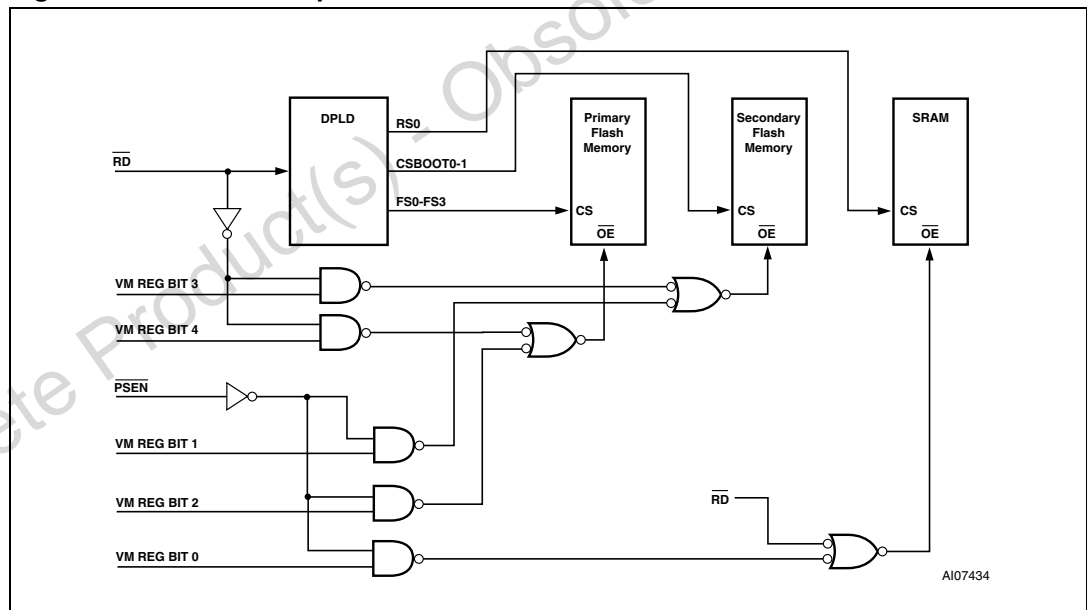

### 21.11 Page register

The 8-bit Page Register increases the addressing capability of the MCU Core by a factor of up to 256. The contents of the register can also be read by the MCU. The outputs of the Page Register (PGR0-PGR7) are inputs to the DPLD decoder and can be included in the Sector Select (FS0-FS7, CSBOOT0-CSBOOT3), and SRAM Select (RS0) equations.

If memory paging is not needed, or if not all 8 page register bits are needed for memory paging, then these bits may be used in the CPLD for general logic.

Figure 52 shows the Page Register. The eight flip-flops in the register are connected to the internal data bus D0-D7. The MCU can write to or read from the Page Register. The Page Register can be accessed at address location CSIOP + E0h.

Figure 52. Page register

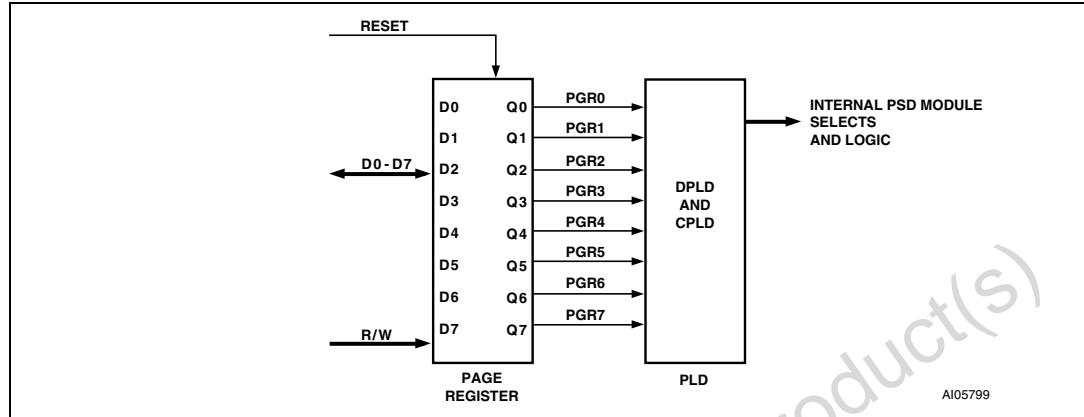

Obsolete Product(s) - Obsolete Product(s)

## 22 PLDs

PLDs bring programmable logic functionality to the UPSD. After specifying the logic for the PLDs using PSDsoft Express, the logic is programmed into the device and available upon Power-up.

**Table 87. DPLD and CPLD Inputs**

Input Source	Input Name	Number of Signals
MCU Address Bus	A15-A0	16
MCU Control Signals	$\overline{\text{PSEN}}$ , $\overline{\text{RD}}$ , $\overline{\text{WR}}$ , ALE	4
RESET	$\overline{\text{RST}}$	1
Power-down	PDN	1
Port A Input Macrocells <sup>(1)</sup>	PA7-PA0	8
Port B Input Macrocells	PB7-PB0	8
Port C Input Macrocells	PC2-4, PC7	4
Port D Inputs	PD2-PD1	2
Page Register	PGR7-PGR0	8
Macrocell AB Feedback	MCELLAB.FB7-FB0	8
Macrocell BC Feedback	MCELLBC.FB7-FB0	8
Flash memory Program Status bit	Ready/ $\overline{\text{Busy}}$	1

Note: 1. These inputs are not available in the 52-pin package.

The PSD module contains two PLDs: the Decode PLD (DPLD), and the Complex PLD (CPLD). The PLDs are briefly discussed in the next few paragraphs, and in more detail in [Section 22.2: Decode PLD \(DPLD\)](#), and [Section 22.3: Complex PLD \(CPLD\)](#). [Figure 53](#) shows the configuration of the PLDs.

The DPLD performs address decoding for Select signals for PSD module components, such as memory, registers, and I/O ports.

The CPLD can be used for logic functions, such as loadable counters and shift registers, state machines, and encoding and decoding logic. These logic functions can be constructed using the Output Macrocells (OMC), Input Macrocells (IMC), and the AND Array. The CPLD can also be used to generate External Chip Select (ECS1-ECS2) signals.

The AND Array is used to form product terms. These product terms are specified using PSDsoft. The PLD input signals consist of internal MCU signals and external inputs from the I/O ports. The input signals are shown in [Table 87](#).

### 22.1 Turbo bit in PSD module

The PLDs can minimize power consumption by switching off when inputs remain unchanged for an extended time of about 70ns. Resetting the Turbo bit to '0' (Bit 3 of PMMR0) automatically places the PLDs into standby if no inputs are changing. Turning the Turbo mode off increases propagation delays while reducing power consumption.

See [Section 24: Power management](#) for details on how to set the Turbo Bit.

Additionally, five bits are available in PMMR2 to block MCU control signals from entering the PLDs. This reduces power consumption and can be used only when these MCU control signals are not used in PLD logic equations.

Each of the two PLDs has unique characteristics suited for its applications. They are described in the following sections.

**Figure 53. PLD diagram**

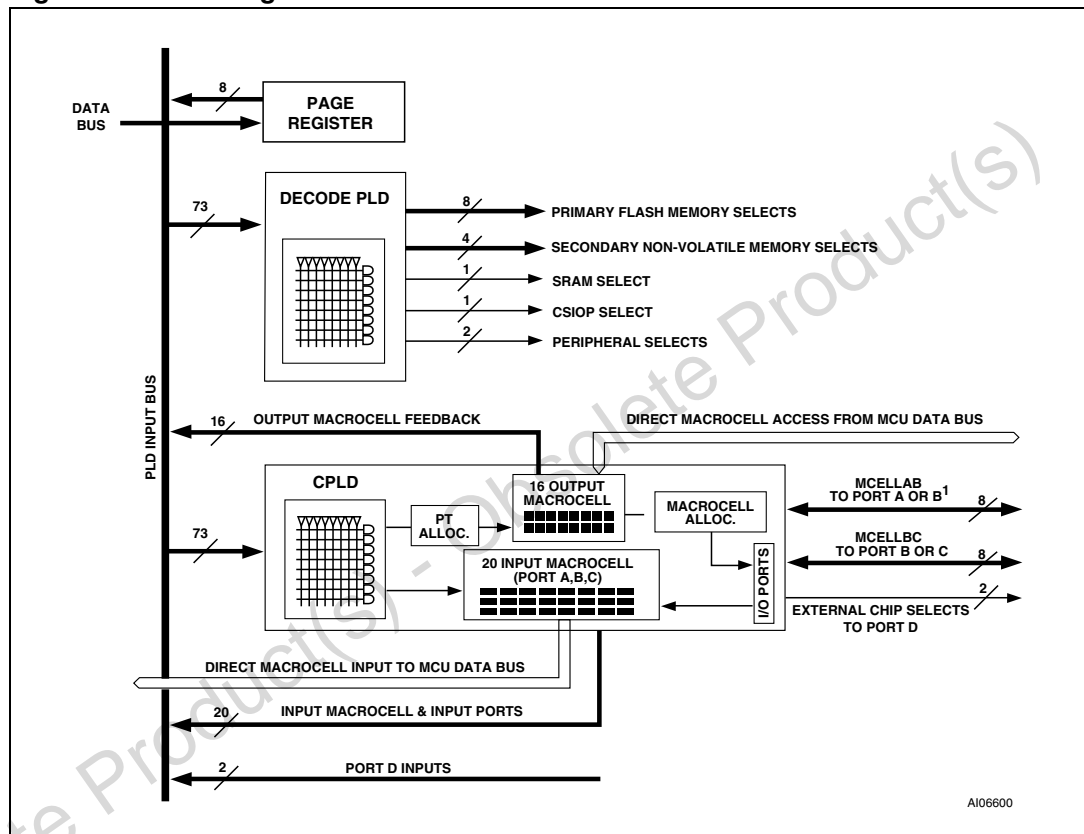

1. Port A is not available in the 52-pin package

## 22.2 Decode PLD (DPLD)

The DPLD, shown in [Figure 88](#), is used for decoding the address for PSD module and external components. The DPLD can be used to generate the following decode signals:

- 4 Sector Select (FS0-FS3) signals for the primary Flash memory (three product terms each)
- 2 Sector Select (CSBOOT0-CSBOOT1) signals for the secondary Flash memory (three product terms each)
- 1 internal SRAM Select (RS0) signal (two product terms)
- 1 internal CSIOP Select signal (selects the PSD module registers)
- 2 internal Peripheral Select signals (Peripheral I/O mode).



Table 88. DPLD logic array

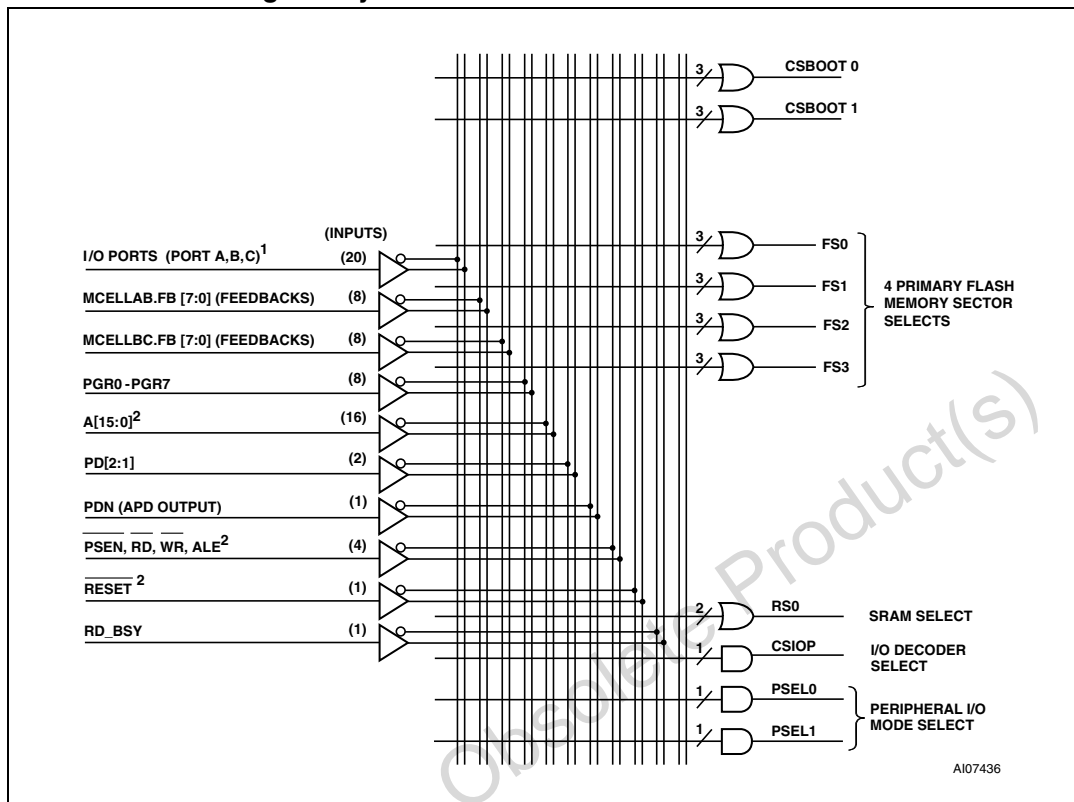

1. Port A inputs are not available in the 52-pin package
2. Inputs from the MCU module

### 22.3 Complex PLD (CPLD)

The CPLD can be used to implement system logic functions, such as loadable counters and shift registers, system mailboxes, handshaking protocols, state machines, and random logic. The CPLD can also be used to generate External Chip Select (ECS1-ECS2), routed to Port D.

Although External Chip Select (ECS1-ECS2) can be produced by any Output Macrocell (OMC), these External Chip Select (ECS1-ECS2) on Port D do not consume any Output Macrocells (OMC).

As shown in [Figure 54](#), the CPLD has the following blocks:

- 20 Input Macrocells (IMC)
- 16 Output Macrocells (OMC)
- Macrocell Allocator
- Product Term Allocator
- AND Array capable of generating up to 137 product terms
- Four I/O Ports.

Each of the blocks are described in the sections that follow.

The Input Macrocells (IMC) and Output Macrocells (OMC) are connected to the PSD module internal data bus and can be directly accessed by the MCU. This enables the MCU software to load data into the Output Macrocells (OMC) or read data from both the Input and Output Macrocells (IMC and OMC).

This feature allows efficient implementation of system logic and eliminates the need to connect the data bus to the AND Array as required in most standard PLD macrocell architectures.

**Figure 54. Macrocell and I/O ports**

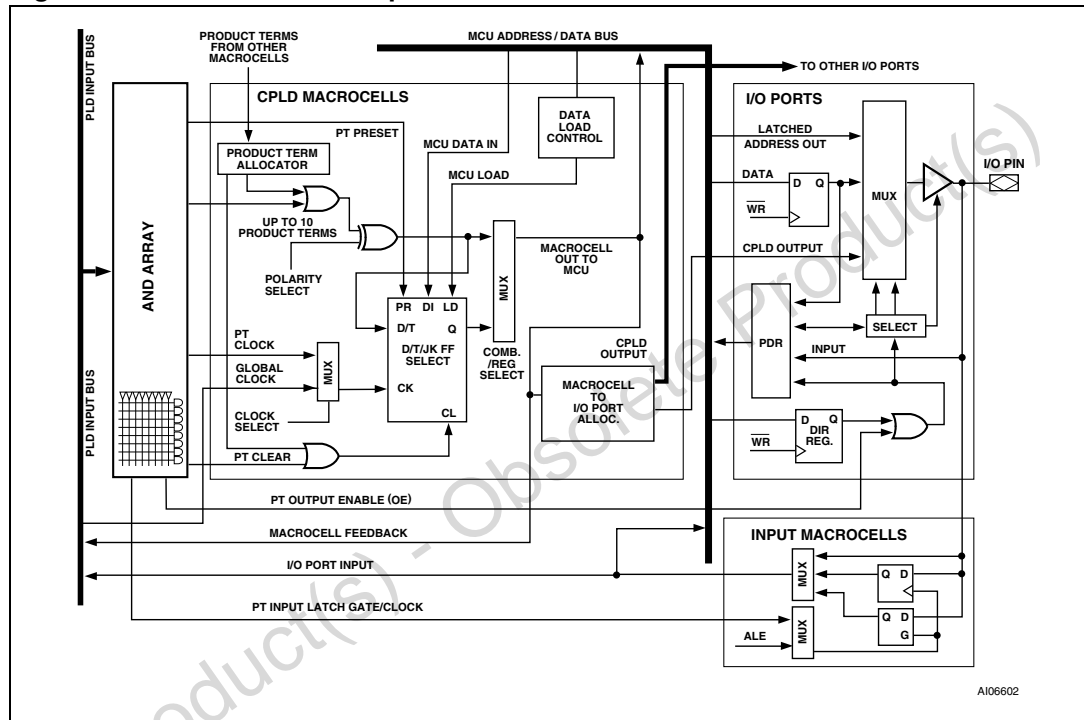

## 22.4 Output macrocell (OMC)

Eight of the Output Macrocells (OMC) are connected to Ports A and B pins and are named as McellAB0-McellAB7. The other eight macrocells are connected to Ports B and C pins and are named as McellBC0-McellBC7. If an McellAB output is not assigned to a specific pin in PSDsoft, the Macrocell Allocator block assigns it to either Port A or B. The same is true for a McellBC output on Port B or C. [Table 89](#) shows the macrocells and port assignment.

The Output Macrocell (OMC) architecture is shown in [Figure 55](#). As shown in the figure, there are native product terms available from the AND Array, and borrowed product terms available (if unused) from other Output Macrocells (OMC). The polarity of the product term is controlled by the XOR gate. The Output Macrocell (OMC) can implement either sequential logic, using the flip-flop element, or combinatorial logic. The multiplexer selects between the sequential or combinatorial logic outputs. The multiplexer output can drive a port pin and has a feedback path to the AND Array inputs.

The flip-flop in the Output Macrocell (OMC) block can be configured as a D, T, JK, or SR type in PSDsoft. The flip-flop's clock, preset, and clear inputs may be driven from a product term of the AND Array. Alternatively, CLKIN (PD1) can be used for the clock input to the flip-

flop. The flip-flop is clocked on the rising edge of CLKIN (PD1). The preset and clear are active High inputs. Each clear input can use up to two product terms.

**Table 89. Output macrocell port and data bit assignments**

Output Macrocell	Port Assignment (1,2)	Native Product Terms	Max. Borrowed Product Terms	Data Bit for Loading or Reading
McellAB0	Port A0, B0	3	6	D0
McellAB1	Port A1, B1	3	6	D1
McellAB2	Port A2, B2	3	6	D2
McellAB3	Port A3, B3	3	6	D3
McellAB4	Port A4, B4	3	6	D4
McellAB5	Port A5, B5	3	6	D5
McellAB6	Port A6, B6	3	6	D6
McellAB7	Port A7, B7	3	6	D7
McellBC0	Port B0	4	5	D0
McellBC1	Port B1	4	5	D1
McellBC2	Port B2, C2	4	5	D2
McellBC3	Port B3, C3	4	5	D3
McellBC4	Port B4, C4	4	6	D4
McellBC5	Port B5	4	6	D5
McellBC6	Port B6	4	6	D6
McellBC7	Port B7, C7	4	6	D7

1. McellAB0-McellAB7 can only be assigned to Port B in the 52-pin package
2. Port PC0, PC1, PC5, and PC6 are assigned to JTAG pins and are not available as Macrocell outputs.

## 22.5 Product term allocator

The CPLD has a Product Term Allocator. PSDsoft uses the Product Term Allocator to borrow and place product terms from one macrocell to another. The following list summarizes how product terms are allocated:

- McellAB0-McellAB7 all have three native product terms and may borrow up to six more
- McellBC0-McellBC3 all have four native product terms and may borrow up to five more
- McellBC4-McellBC7 all have four native product terms and may borrow up to six more.

Each macrocell may only borrow product terms from certain other macrocells. Product terms already in use by one macrocell are not available for another macrocell.

If an equation requires more product terms than are available to it, then “external” product terms are required, which consume other Output Macrocells (OMC). If external product terms are used, extra delay is added for the equation that required the extra product terms.

This is called product term expansion. PSDsoft Express performs this expansion as needed.



AND Array, ORed with the Direction Register output. The pin is enabled upon Power-up if no output enable equation is defined and if the pin is declared as a PLD output in PSDsoft Express.

If the Output Macrocell (OMC) output is declared as an internal node and not as a port pin output in the PSDabel file, the port pin can be used for other I/O functions. The internal node feedback can be routed as an input to the AND Array.

## 22.6 Input macrocells (IMC)

The CPLD has 20 Input Macrocells (IMC), one for each pin on Ports A and B, and 4 on Port C. The architecture of the Input Macrocells (IMC) is shown in *Figure 56*. The Input Macrocells (IMC) are individually configurable, and can be used as a latch, register, or to pass incoming Port signals prior to driving them onto the PLD input bus. The outputs of the Input Macrocells (IMC) can be read by the MCU through the internal data bus.

The enable for the latch and clock for the register are driven by a multiplexer whose inputs are a product term from the CPLD AND Array or the MCU Address Strobe (ALE). Each product term output is used to latch or clock four Input Macrocells (IMC). Port inputs 3-0 can be controlled by one product term and 7-4 by another.

Configurations for the Input Macrocells (IMC) are specified by equations written in PSDsoft (see Application Note AN1171). Outputs of the Input Macrocells (IMC) can be read by the MCU via the IMC buffer.

See *Section 23: I/O ports (PSD module)*.

**Figure 56. Input macrocell**

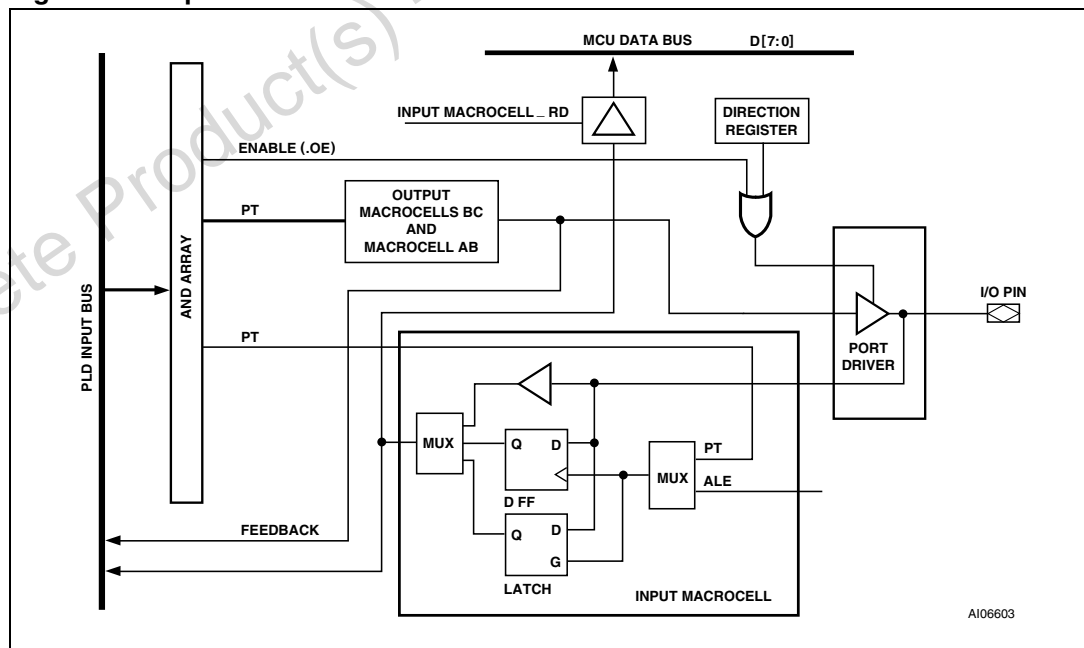

## 23 I/O ports (PSD module)

There are four programmable I/O ports: Ports A, B, C, and D in the PSD module. Each of the ports is eight bits except Port D, which is 3 bits. Each port pin is individually user configurable, thus allowing multiple functions per port. The ports are configured using PSDsoft Express Configuration or by the MCU writing to on-chip registers in the CSIOP space. Port A is not available in the 52-pin package.

The topics discussed in this section are:

- General Port architecture
- Port operating modes
- Port Configuration Registers (PCR)
- Port Data Registers
- Individual Port functionality.

### 23.1 General port architecture

The general architecture of the I/O Port block is shown in [Figure 57](#). Individual Port architectures are shown in [Figure 59](#) to [Figure 62](#). In general, once the purpose for a port pin has been defined, that pin is no longer available for other purposes. Exceptions are noted.

As shown in [Figure 57](#), the ports contain an output multiplexer whose select signals are driven by the configuration bits in the Control Registers (Ports A and B only) and PSDsoft Express Configuration. Inputs to the multiplexer include the following:

- Output data from the Data Out register
- Latched address outputs
- CPLD macrocell output
- External Chip Select (ECS1-ECS2) from the CPLD.

The Port Data Buffer (PDB) is a tri-state buffer that allows only one source at a time to be read. The Port Data Buffer (PDB) is connected to the Internal Data Bus for feedback and can be read by the MCU. The Data Out and macrocell outputs, Direction and Control Registers, and port pin input are all connected to the Port Data Buffer (PDB).

Figure 57. General I/O port architecture

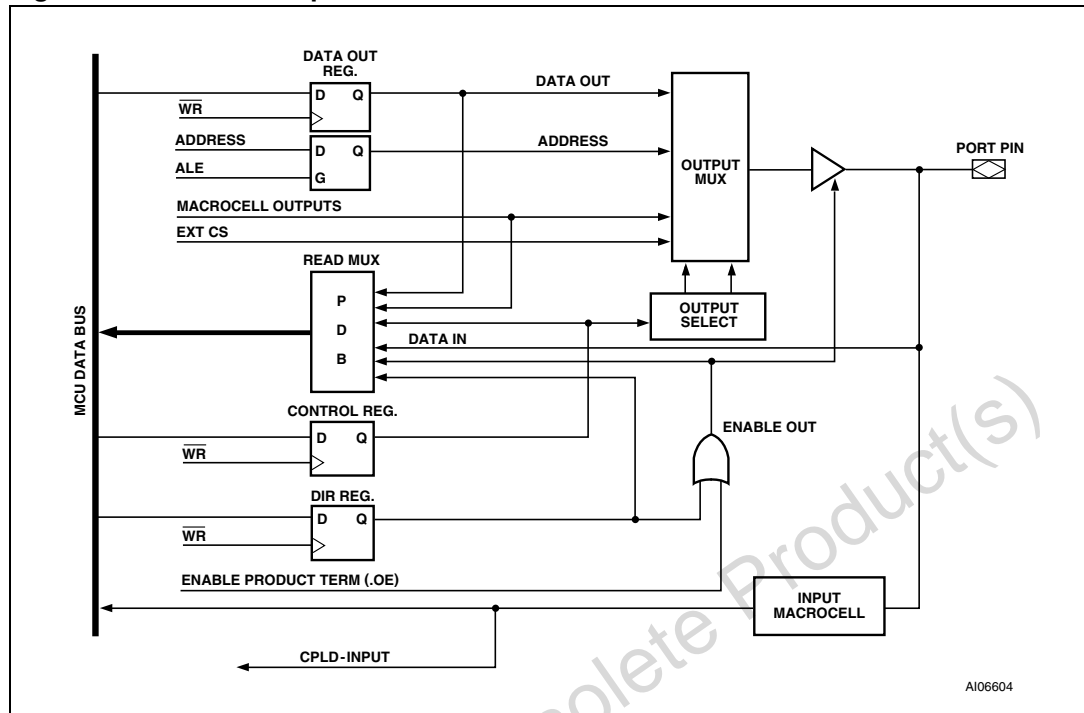

The Port pin's tri-state output driver enable is controlled by a two input OR gate whose inputs come from the CPLD AND Array enable product term and the Direction Register. If the enable product term of any of the Array outputs are not defined and that port pin is not defined as a CPLD output in the PSDsoft, then the Direction Register has sole control of the buffer that drives the port pin.

The contents of these registers can be altered by the MCU. The Port Data Buffer (PDB) feedback path allows the MCU to check the contents of the registers.

Ports A, B, and C have embedded Input Macrocells (IMC). The Input Macrocells (IMC) can be configured as latches, registers, or direct inputs to the PLDs. The latches and registers are clocked by Address Strobe (ALE) or a product term from the PLD AND Array. The outputs from the Input Macrocells (IMC) drive the PLD input bus and can be read by the MCU. See [Figure 56](#).

## 23.2 Port operating modes

The I/O Ports have several modes of operation. Some modes can be defined using PSDsoft, some by the MCU writing to the Control Registers in CSIOP space, and some by both. The modes that can only be defined using PSDsoft must be programmed into the device and cannot be changed unless the device is reprogrammed. The modes that can be changed by the MCU can be done so dynamically at run-time. The PLD I/O, Data Port, Address Input, and Peripheral I/O modes are the only modes that must be defined before programming the device. All other modes can be changed by the MCU at run-time. See Application Note [AN1171](#) for more detail.

[Table 90](#) summarizes which modes are available on each port. [Table 93](#) shows how and where the different modes are configured. Each of the port operating modes are described in the following sections.

### 23.3 MCU I/O mode

In the MCU I/O mode, the MCU uses the I/O Ports block to expand its own I/O ports. By setting up the CSIOP space, the ports on the PSD module are mapped into the MCU address space. The addresses of the ports are listed in [Table 81](#).

A port pin can be put into MCU I/O mode by writing a '0' to the corresponding bit in the Control Register. The MCU I/O direction may be changed by writing to the corresponding bit in the Direction Register, or by the output enable product term. See [Section 23.6: Peripheral I/O mode](#). When the pin is configured as an output, the content of the Data Out Register drives the pin. When configured as an input, the MCU can read the port input through the Data In buffer. See [Figure 57](#).

Ports C and D do not have Control Registers, and are in MCU I/O mode by default. They can be used for PLD I/O if equations are written for them in PSDlabel.

### 23.4 PLD I/O mode

The PLD I/O mode uses a port as an input to the CPLD's Input Macrocells (IMC), and/or as an output from the CPLD's Output Macrocells (OMC). The output can be tri-stated with a control signal. This output enable control signal can be defined by a product term from the PLD, or by resetting the corresponding bit in the Direction Register to '0.' The corresponding bit in the Direction Register must not be set to '1' if the pin is defined for a PLD input signal in PSDsoft. The PLD I/O mode is specified in PSDsoft by declaring the port pins, and then writing an equation assigning the PLD I/O to a port.

### 23.5 Address Out mode

Address Out mode can be used to drive latched MCU addresses on to the port pins. These port pins can, in turn, drive external devices. Either the output enable or the corresponding bits of both the Direction Register and Control Register must be set to a '1' for pins to use Address Out mode. This must be done by the MCU at run-time. See [Table 92](#) for the address output pin assignments on Ports A and B for various MCUs.

### 23.6 Peripheral I/O mode

Peripheral I/O mode can be used to interface with external peripherals. In this mode, all of Port A serves as a tri-state, bi-directional data buffer for the MCU. Peripheral I/O mode is enabled by setting Bit 7 of the VM Register to a '1.' [Figure 58](#) shows how Port A acts as a bi-directional buffer for the MCU data bus if Peripheral I/O mode is enabled. An equation for PSEL0 and/or PSEL1 must be written in PSDsoft. The buffer is tri-stated when PSEL0 or PSEL1 is low (not active). The PSEN signal should be "ANDed" in the PSEL equations to disable the buffer when PSEL resides in the data space.

### 23.7 JTAG in-system programming (ISP)

Port C is JTAG compliant, and can be used for In-System Programming (ISP). For more information on the JTAG Port, see [Section 26: Programming in-circuit using the JTAG serial interface](#).



Figure 58. Peripheral I/O mode

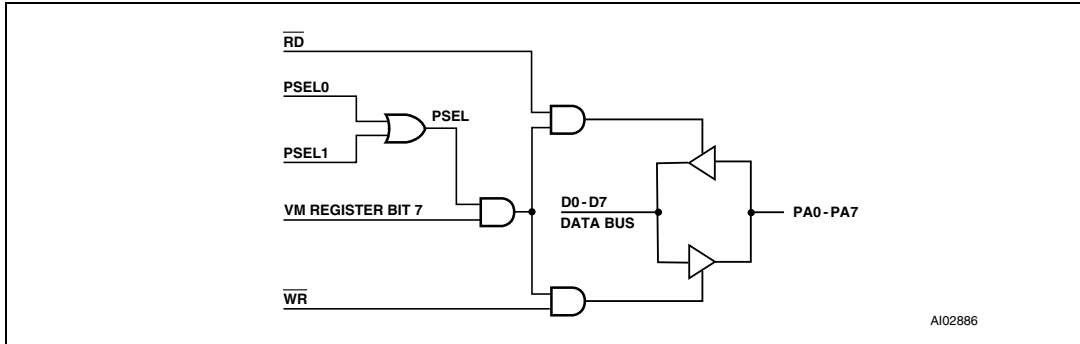

Table 90. Port operating modes

Port mode	Port A <sup>(1)</sup>	Port B	Port C	Port D
MCU I/O	Yes	Yes	Yes	Yes
PLD I/O				
McellAB Outputs	Yes	Yes	No	No
McellBC Outputs	No	Yes	Yes <sup>(2)</sup>	No
Additional Ext. CS Outputs	No	No	No	Yes
PLD Inputs	Yes	Yes	Yes	Yes
Address Out	Yes (A7 – 0)	Yes (A7 – 0)	No	No
Peripheral I/O	Yes	No	No	No
JTAG ISP	No	No	Yes <sup>(3)</sup>	No

1. Port A is not available in the 52-pin package.
2. On pins PC2, PC3, PC4, and PC7 only.
3. JTAG pins (TMS, TCK, TDI, TDO) are dedicated pins.

Table 91. Port operating mode settings

Mode	Defined in PSDsoft	Control Register Setting <sup>(1)</sup>	Direction Register Setting <sup>(1)</sup>	VM Register Setting <sup>(1)</sup>
MCU I/O	Declare pins only	0	1 = output, 0 = input (Note 2)	N/A
PLD I/O	Logic equations	N/A	(Note 2)	N/A
Address Out (Port A,B)	Declare pins only	1	1 (Note 2)	N/A
Peripheral I/O (Port A)	Logic equations (PSEL0 & 1)	N/A	N/A	PIO Bit = 1

1. N/A = Not Applicable
2. The direction of the Port A,B,C, and D pins are controlled by the Direction Register ORed with the individual output enable product term (.oe) from the CPLD AND Array.

Table 92. I/O port latched address output assignments

Port A (PA3-PA0)	Port A (PA7-PA4)	Port B (PB3-PB0)	Port B (PB7-PB4)
Address a3-a0	Address a7-a4	Address a3-a0	Address a7-a4

## 23.8 Port configuration registers (PCR)

Each Port has a set of Port Configuration Registers (PCR) used for configuration. The contents of the registers can be accessed by the MCU through normal READ/WRITE bus cycles at the addresses given in [Table 81](#). The addresses in [Table 81](#) are the offsets in hexadecimal from the base of the CSIOP register.

The pins of a port are individually configurable and each bit in the register controls its respective pin. For example, Bit 0 in a register refers to Bit 0 of its port. The three Port Configuration Registers (PCR), shown in [Table 93](#), are used for setting the Port configurations. The default Power-up state for each register in [Table 93](#) is 00h.

### 23.8.1 Control register

Any bit reset to '0' in the Control Register sets the corresponding port pin to MCU I/O mode, and a '1' sets it to Address Out mode. The default mode is MCU I/O. Only Ports A and B have an associated Control Register.

### 23.8.2 Direction register

The Direction Register, in conjunction with the output enable (except for Port D), controls the direction of data flow in the I/O Ports. Any bit set to '1' in the Direction Register causes the corresponding pin to be an output, and any bit set to '0' causes it to be an input. The default mode for all port pins is input.

[Figure 59](#) and [Figure 60](#) show the Port Architecture diagrams for Ports A/B and C, respectively. The direction of data flow for Ports A, B, and C are controlled not only by the direction register, but also by the output enable product term from the PLD AND Array. If the output enable product term is not active, the Direction Register has sole control of a given pin's direction.

An example of a configuration for a Port with the three least significant bits set to output and the remainder set to input is shown in [Table 96](#). Since Port D only contains two pins (shown in [Figure 62](#)), the Direction Register for Port D has only two bits active.

### 23.8.3 Drive Select register

The Drive Select Register configures the pin driver as Open Drain or CMOS for some port pins, and controls the slew rate for the other port pins. An external pull-up resistor should be used for pins configured as Open Drain.

A pin can be configured as Open Drain if its corresponding bit in the Drive Select Register is set to a '1.' The default pin drive is CMOS.

*Note:* *The slew rate is a measurement of the rise and fall times of an output. A higher slew rate means a faster output response and may create more electrical noise. A pin operates in a high slew rate when the corresponding bit in the Drive Register is set to '1.' The default rate is slow slew.*

[Table 97](#) shows the Drive Register for Ports A, B, C, and D. It summarizes which pins can be configured as Open Drain outputs and which pins the slew rate can be set for.

**Table 93. Port configuration registers (PCR)**

Register Name	Port	MCU Access
Control	A,B	WRITE/READ
Direction	A,B,C,D	WRITE/READ
Drive Select <sup>(1)</sup>	A,B,C,D	WRITE/READ

Note: 1. See [Table 97](#) for Drive Register Bit definition.

**Table 94. Port pin direction control, output enable P.T. not defined**

Direction Register Bit	Port Pin mode
0	Input
1	Output

**Table 95. Port pin direction control, output enable P.T. defined**

Direction Register Bit	Output Enable P.T.	Port Pin mode
0	0	Input
0	1	Output
1	0	Output
1	1	Output

**Table 96. Port direction assignment example**

Bit 7	Bit 6	Bit 5	Bit 4	Bit 3	Bit 2	Bit 1	Bit 0
0	0	0	0	0	1	1	1

## 23.9 Port data registers

The Port Data Registers, shown in [Table 98](#), are used by the MCU to write data to or read data from the ports. [Table 98](#) shows the register name, the ports having each register type, and MCU access for each register type. The registers are described below.

### 23.9.1 Data In

Port pins are connected directly to the Data In buffer. In MCU I/O Input mode, the pin input is read through the Data In buffer.

### 23.9.2 Data Out register

Stores output data written by the MCU in the MCU I/O Output mode. The contents of the Register are driven out to the pins if the Direction Register or the output enable product term is set to '1.' The contents of the register can also be read back by the MCU.

### 23.9.3 Output macrocells (OMC)

The CPLD Output Macrocells (OMC) occupy a location in the MCU's address space. The MCU can read the output of the Output Macrocells (OMC). If the OMC Mask Register Bits

are not set, writing to the macrocell loads data to the macrocell flip-flops. See [Section 22: PLDs](#).

### 23.9.4 OMC mask register

Each OMC Mask Register Bit corresponds to an Output Macrocell (OMC) flip-flop. When the OMC Mask Register Bit is set to a '1,' loading data into the Output Macrocell (OMC) flip-flop is blocked. The default value is '0' or unblocked.

### 23.9.5 Input macrocells (IMC)

The Input Macrocells (IMC) can be used to latch or store external inputs. The outputs of the Input Macrocells (IMC) are routed to the PLD input bus, and can be read by the MCU. See [Section 22: PLDs](#).

### 23.9.6 Enable out

The Enable Out register can be read by the MCU. It contains the output enable values for a given port. A '1' indicates the driver is in output mode. A '0' indicates the driver is in tri-state and the pin is in input mode.

**Table 97. Drive register pin assignment**

Drive Register	Bit 7	Bit 6	Bit 5	Bit 4	Bit 3	Bit 2	Bit 1	Bit 0
Port A	Open Drain	Open Drain	Open Drain	Open Drain	Slew Rate	Slew Rate	Slew Rate	Slew Rate
Port B	Open Drain	Open Drain	Open Drain	Open Drain	Slew Rate	Slew Rate	Slew Rate	Slew Rate
Port C	Open Drain	NA <sup>(1)</sup>	NA <sup>(1)</sup>	Open Drain	Open Drain	Open Drain	NA <sup>(1)</sup>	NA <sup>(1)</sup>
Port D	NA <sup>(1)</sup>	NA <sup>(1)</sup>	NA <sup>(1)</sup>	NA <sup>(1)</sup>	NA <sup>(1)</sup>	Slew Rate	Slew Rate	NA <sup>(1)</sup>

1. NA = Not Applicable.

**Table 98. Port data registers**

Register Name	Port	MCU Access
Data In	A,B,C,D	READ – input on pin
Data Out	A,B,C,D	WRITE/READ
Output Macrocell	A,B,C	READ – outputs of macrocells WRITE – loading macrocells flip-flop
Mask Macrocell	A,B,C	WRITE/READ – prevents loading into a given macrocell
Input Macrocell	A,B,C	READ – outputs of the Input Macrocells
Enable Out	A,B,C	READ – the output enable control of the port driver

## 23.10 Ports A and B – functionality and structure

Ports A and B have similar functionality and structure, as shown in [Figure 59](#). The two ports can be configured to perform one or more of the following functions:

- MCU I/O mode
- CPLD Output – Macrocells McellAB7-McellAB0 can be connected to Port A or Port B. McellBC7-McellBC0 can be connected to Port B or Port C.
- CPLD Input – Via the Input Macrocells (IMC).
- Latched Address output – Provide latched address output as per [Table 92](#).
- Open Drain/Slew Rate – pins PA3-PA0 and PB3-PB0 can be configured to fast slew rate, pins PA7-PA4 and PB7-PB4 can be configured to Open Drain mode.
- Peripheral mode – Port A only (80-pin package)

**Figure 59. Port A and Port B structure**

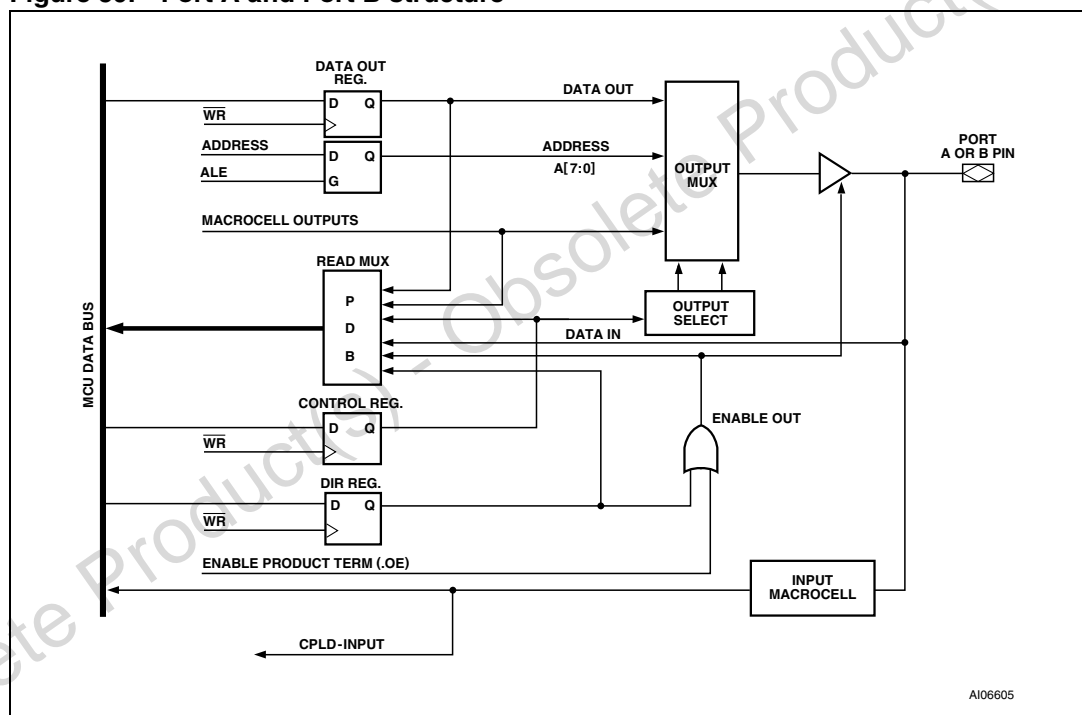

## 23.11 Port C – functionality and structure

Port C can be configured to perform one or more of the following functions (see [Figure 60](#)):

- MCU I/O mode
- CPLD Output – McellBC7-McellBC0 outputs can be connected to Port B or Port C.
- CPLD Input – via the Input Macrocells (IMC)
- In-System Programming (ISP) – JTAG pins (TMS, TCK, TDI, TDO) are dedicated pins for device programming. (See [Section 26: Programming in-circuit using the JTAG serial interface](#), for more information on JTAG programming.)
- Open Drain – Port C pins can be configured in Open Drain mode

Port C does not support Address Out mode, and therefore no Control Register is required.

Figure 60. Port C structure

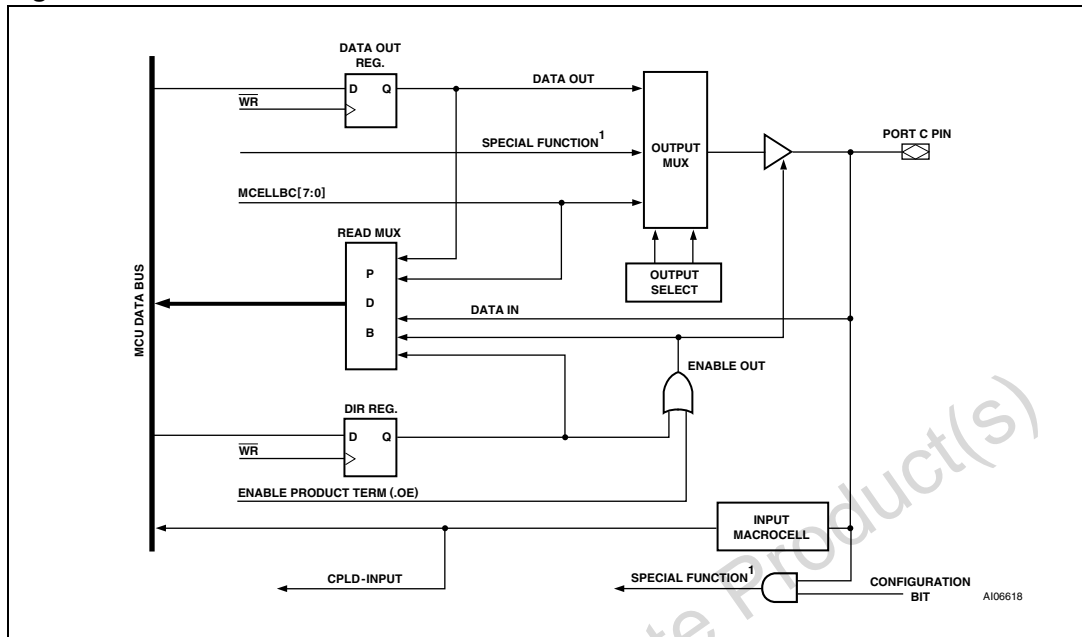

Note: 1. ISP

### 23.12 Port D – functionality and structure

Port D has two I/O pins (only one pin, PD1, in the 52-pin package). See [Figure 61](#) and [Figure 62](#). This port does not support Address Out mode, and therefore no Control Register is required. Of the eight bits in the Port D registers, only Bits 2 and 1 are used to configure pins PD2 and PD1.

Port D can be configured to perform one or more of the following functions:

- MCU I/O mode
- CPLD Output – External Chip Select (ECS1-ECS2)
- CPLD Input – direct input to the CPLD, no Input Macrocells (IMC)
- Slew rate – pins can be set up for fast slew rate

Port D pins can be configured in PSDsoft Express as input pins for other dedicated functions:

- CLKIN (PD1) as input to the macrocells flip-flops and APD counter
- PSD Chip Select Input ( $\overline{CS1}$ , PD2). Driving this signal High disables the Flash memory, SRAM and CSIOP.

Figure 61. Port D structure

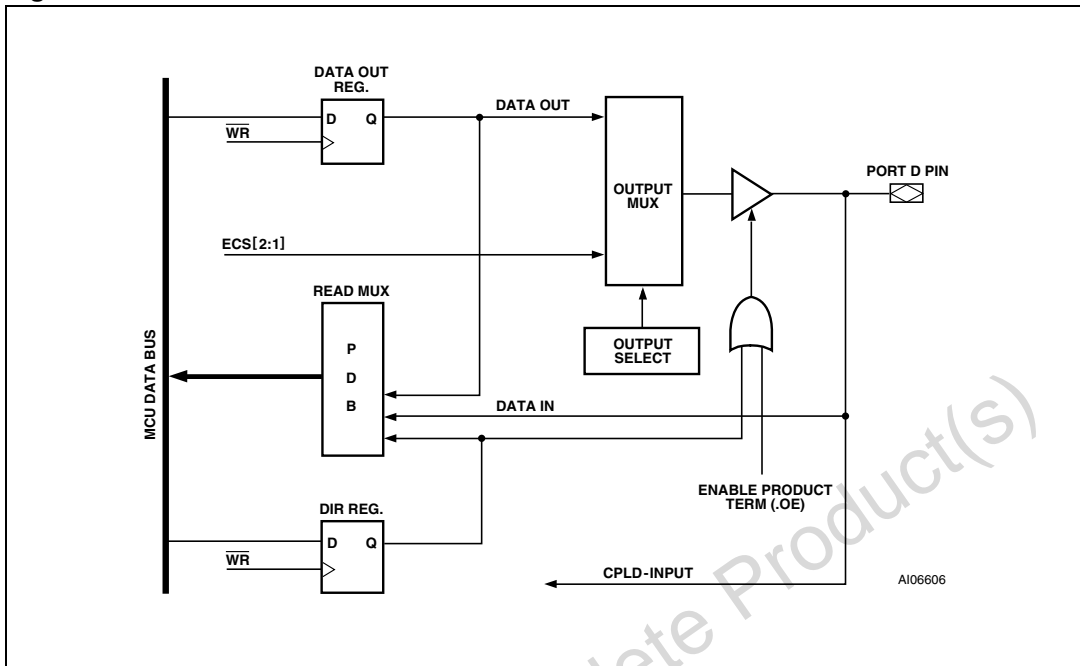

### 23.13 External chip select

The CPLD also provides two External Chip Select (ECS1-ECS2) outputs on Port D pins that can be used to select external devices. Each External Chip Select (ECS1-ECS2) consists of one product term that can be configured active High or Low. The output enable of the pin is controlled by either the output enable product term or the Direction register. (See [Figure 62.](#))

Figure 62. Port D external chip select signals

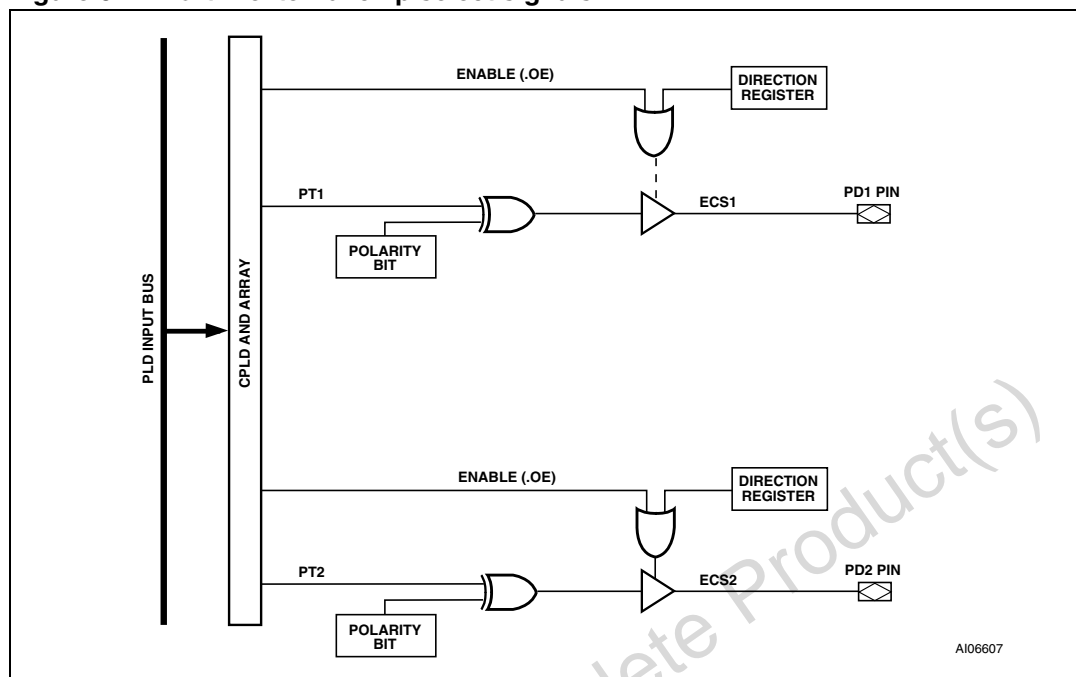

A106607

Obsolete Product(s) - Obsolete Product(s)



## 24 Power management

All PSD modules offer configurable power saving options. These options may be used individually or in combinations, as follows:

- The primary and secondary Flash memory, and SRAM blocks are built with power management technology. In addition to using special silicon design methodology, power management technology puts the memories into Standby mode when address/data inputs are not changing (zero DC current). As soon as a transition occurs on an input, the affected memory “wakes up,” changes and latches its outputs, then goes back to standby. The designer does *not* have to do anything special to achieve Memory Standby mode when no inputs are changing—it happens automatically.
- The PLD sections can also achieve Standby mode when its inputs are not changing, as described in the sections on the Power Management mode Registers (PMMR).
- As with the Power Management mode, the Automatic Power Down (APD) block allows the PSD module to reduce to Standby current automatically. The APD Unit can also block MCU address/data signals from reaching the memories and PLDs.
- Built in logic monitors the Address Strobe of the MCU for activity. If there is no activity for a certain time period (MCU is asleep), the APD Unit initiates Power-down mode (if enabled). Once in Power-down mode, all address/data signals are blocked from reaching memory and PLDs, and the memories are deselected internally. This allows the memory and PLDs to remain in Standby mode even if the address/data signals are changing state externally (noise, other devices on the MCU bus, etc.). Keep in mind that any unblocked PLD input signals that are changing states keeps the PLD out of Standby mode, but not the memories.
- PSD Chip Select Input ( $\overline{\text{CSI}}$ , PD2) can be used to disable the internal memories, placing them in Standby mode even if inputs are changing. This feature does not block any internal signals or disable the PLDs. This is a good alternative to using the APD Unit. There is a slight penalty in memory access time when PSD Chip Select Input ( $\overline{\text{CSI}}$ , PD2) makes its initial transition from deselected to selected.
- The PMMRs can be written by the MCU at run-time to manage power. The PSD module supports “blocking bits” in these registers that are set to block designated signals from reaching both PLDs. Current consumption of the PLDs is directly related to the composite frequency of the changes on their inputs (see [Figure 66](#) and [Figure 67](#)). Significant power savings can be achieved by blocking signals that are not used in DPLD or CPLD logic equations.

Figure 63. APD unit

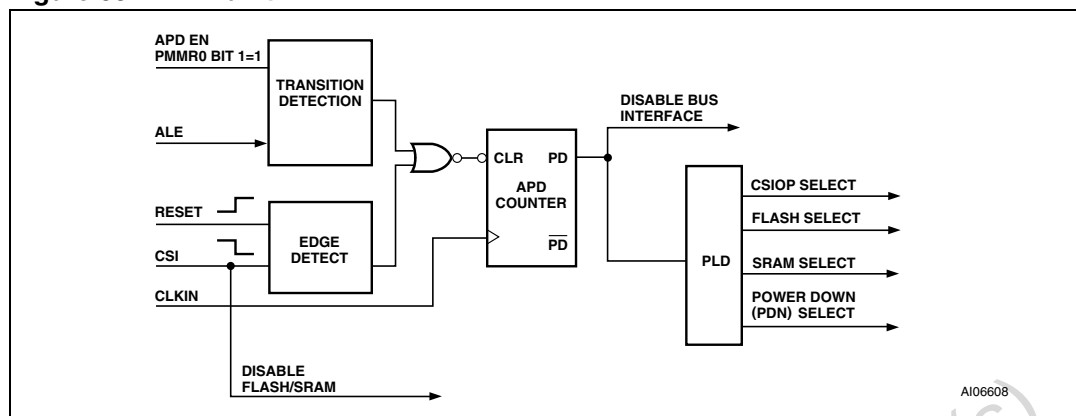

The PSD module has a Turbo Bit in PMMR0. This bit can be set to turn the Turbo mode off (the default is with Turbo mode turned on). While Turbo mode is off, the PLDs can achieve standby current when no PLD inputs are changing (zero DC current). Even when inputs do change, significant power can be saved at lower frequencies (AC current), compared to when Turbo mode is on. When the Turbo mode is on, there is a significant DC current component and the AC component is higher.

### Automatic Power-down (APD) Unit and Power-down mode

The APD Unit, shown in [Figure 63](#), puts the PSD module into Power-down mode by monitoring the activity of Address Strobe (ALE). If the APD Unit is enabled, as soon as activity on Address Strobe (ALE) stops, a four-bit counter starts counting. If Address Strobe (ALE/AS, PD0) remains inactive for fifteen clock periods of CLKIN (PD1), Power-down (PDN) goes High, and the PSD module enters Power-down mode, as discussed next.

### Power-down mode

By default, if you enable the APD Unit, Power-down mode is automatically enabled. The device enters Power-down mode if Address Strobe (ALE) remains inactive for fifteen periods of CLKIN (PD1).

The following should be kept in mind when the PSD module is in Power-down mode:

- If Address Strobe (ALE) starts pulsing again, the PSD module returns to normal Operating mode. The PSD module also returns to normal Operating mode if either PSD Chip Select Input ( $\overline{\text{CSI}}$ , PD2) is Low or the  $\overline{\text{RESET}}$  input is High.
- The MCU address/data bus is blocked from all memory and PLDs.
- Various signals can be blocked (prior to Power-down mode) from entering the PLDs by setting the appropriate bits in the PMMR registers. The blocked signals include MCU control signals and the common CLKIN (PD1).

*Note:* Blocking CLKIN (PD1) from the PLDs does not block CLKIN (PD1) from the APD Unit.

- All memories enter Standby mode and are drawing standby current. However, the PLD and I/O ports blocks do *not* go into Standby mode because you don't want to have to wait for the logic and I/O to "wake-up" before their outputs can change. See [Table 99](#) for Power-down mode effects on PSD module ports.
- Typical standby current is of the order of microamperes. These standby current values assume that there are no transitions on any PLD input.

### Other power-saving options

The PSD module offers other reduced power saving options that are independent of the Power-down mode. Except for the PSD Chip Select Input ( $\overline{CSI}$ , PD2) features, they are enabled by setting bits in PMMR0 and PMMR2.

**Figure 64. Enable Power-down flowchart**

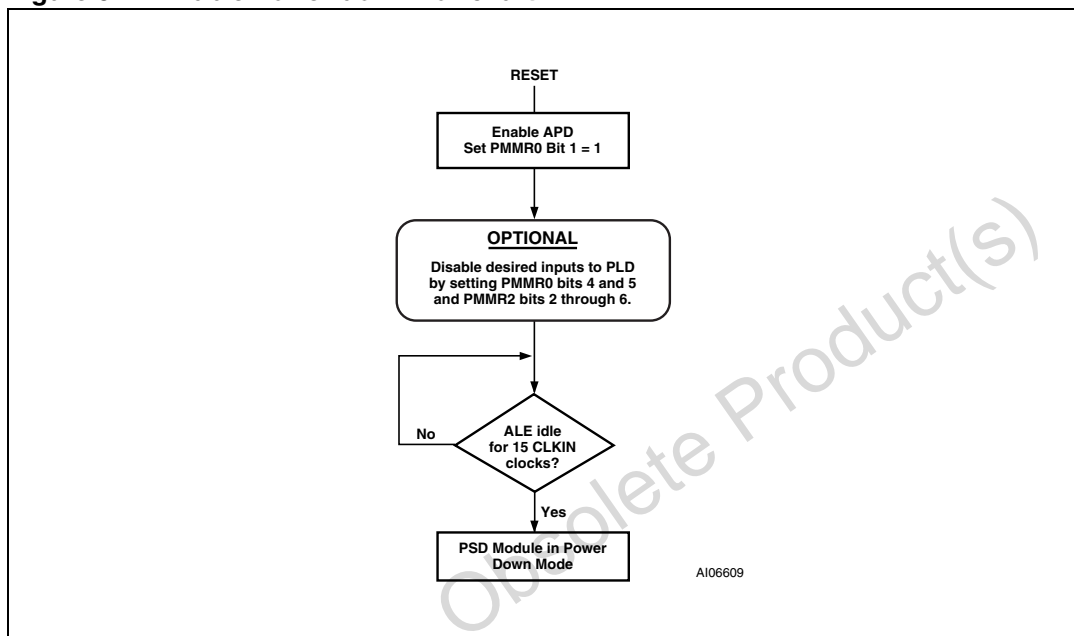

**Table 99. Power-down mode’s effect on ports**

Port Function	Pin Level
MCU I/O	No Change
PLD Out	No Change
Address Out	Undefined
Peripheral I/O	Tri-State

## 24.1 PLD power management

The power and speed of the PLDs are controlled by the Turbo Bit (Bit 3) in PMMR0. By setting the bit to '1,' the Turbo mode is off and the PLDs consume the specified Standby current when the inputs are not switching for an extended time of 70 ns. The propagation delay time is increased by 10 ns (for a 5 V device) after the Turbo Bit is set to '1' (turned off) when the inputs change at a composite frequency of less than 15MHz. When the Turbo Bit is reset to '0' (turned on), the PLDs run at full power and speed. The Turbo Bit affects the PLD’s DC power, AC power, and propagation delay. When the Turbo mode is off, the UPSD321xx devices’ input clock frequency is reduced by 5 MHz from the maximum rated clock frequency.

Blocking MCU control signals with the bits of PMMR2 can further reduce PLD AC power consumption.

## 24.2 PSD chip select input ( $\overline{\text{CSI}}$ , PD2)

PD2 of Port D can be configured in PSDsoft Express as PSD Chip Select Input ( $\overline{\text{CSI}}$ ). When Low, the signal selects and enables the PSD module Flash memory, SRAM, and I/O blocks for READ or WRITE operations. A High on PSD Chip Select Input ( $\overline{\text{CSI}}$ , PD2) disables the Flash memory, and SRAM, and reduces power consumption. However, the PLD and I/O signals remain operational when PSD Chip Select Input ( $\overline{\text{CSI}}$ , PD2) is High.

## 24.3 Input clock

CLKIN (PD1) can be turned off, to the PLD to save AC power consumption. CLKIN (PD1) is an input to the PLD AND Array and the Output Macrocells (OMC).

During Power-down mode, or, if CLKIN (PD1) is not being used as part of the PLD logic equation, the clock should be disabled to save AC power. CLKIN (PD1) is disconnected from the PLD AND Array or the Macrocells block by setting Bits 4 or 5 to a '1' in PMMR0.

## 24.4 Input control signals

The PSD module provides the option to turn off the MCU signals ( $\overline{\text{WR}}$ ,  $\overline{\text{RD}}$ ,  $\overline{\text{PSEN}}$ , and Address Strobe (ALE)) to the PLD to save AC power consumption. These control signals are inputs to the PLD AND Array. During Power-down mode, or, if any of them are not being used as part of the PLD logic equation, these control signals should be disabled to save AC power. They are disconnected from the PLD AND Array by setting Bits 2, 3, 4, 5, and 6 to a '1' in PMMR2.

**Table 100. Power management mode registers (PMMR0)**

Bit 0	X	0	Not used, and should be set to zero.
Bit 1	APD Enable	0 = off	Automatic Power-down (APD) is disabled.
		1 = on	Automatic Power-down (APD) is enabled.
Bit 2	X	0	Not used, and should be set to zero.
Bit 3	PLD Turbo	0 = on	PLD Turbo mode is on
		1 = off	PLD Turbo mode is off, saving power. UPSD321xx devices operate at 5MHz below the maximum rated clock frequency
Bit 4	PLD Array clk	0 = on	CLKIN (PD1) input to the PLD AND Array is connected. Every change of CLKIN (PD1) Powers-up the PLD when Turbo Bit is '0.'
		1 = off	CLKIN (PD1) input to PLD AND Array is disconnected, saving power.
Bit 5	PLD MCell clk	0 = on	CLKIN (PD1) input to the PLD macrocells is connected.
		1 = off	CLKIN (PD1) input to PLD macrocells is disconnected, saving power.
Bit 6	X	0	Not used, and should be set to zero.
Bit 7	X	0	Not used, and should be set to zero.

**Table 101. Power management mode registers (PMMR2)**

Bit 0	X	0	Not used, and should be set to zero.
Bit 1	X	0	Not used, and should be set to zero.
Bit 2	PLD Array WR	0 = on	$\overline{WR}$ input to the PLD AND Array is connected.
		1 = off	$\overline{WR}$ input to PLD AND Array is disconnected, saving power.
Bit 3	PLD Array RD	0 = on	$\overline{RD}$ input to the PLD AND Array is connected.
		1 = off	$\overline{RD}$ input to PLD AND Array is disconnected, saving power.
Bit 4	PLD Array PSEN	0 = on	$\overline{PSEN}$ input to the PLD AND Array is connected.
		1 = off	$\overline{PSEN}$ input to PLD AND Array is disconnected, saving power.
Bit 5	PLD Array ALE	0 = on	ALE input to the PLD AND Array is connected.
		1 = off	ALE input to PLD AND Array is disconnected, saving power.
Bit 6	X	0	Not used, and should be set to zero.
Bit 7	X	0	Not used, and should be set to zero.

1. The bits of this register are cleared to zero following Power-up. Subsequent  $\overline{RESET}$  pulses do not clear the registers.

**Table 102. APD counter operatio**

APD Enable Bit	ALE Level	APD Counter
0	X	Not Counting
1	Pulsing	Not Counting
1	0 or 1	Counting (Generates PDN after 15 Clocks)

## 25 RESET timing and device status at reset

Upon Power-up, the PSD module requires a Reset ( $\overline{\text{RESET}}$ ) pulse of duration  $t_{\text{NLNH-PO}}$  after  $V_{\text{CC}}$  is steady. During this period, the device loads internal configurations, clears some of the registers and sets the Flash memory into operating mode. After the rising edge of Reset ( $\overline{\text{RESET}}$ ), the PSD module remains in the Reset mode for an additional period,  $t_{\text{OPR}}$ , before the first memory access is allowed.

The Flash memory is reset to the READ mode upon Power-up. Sector Select (FS0-FS3 and CSBOOT0-CSBOOT1) must all be Low, WRITE Strobe ( $\overline{\text{WR}}$ , CNTL0) High, during Power-on  $\overline{\text{RESET}}$  for maximum security of the data contents and to remove the possibility of a byte being written on the first edge of WRITE Strobe ( $\overline{\text{WR}}$ ). Any Flash memory WRITE cycle initiation is prevented automatically when  $V_{\text{CC}}$  is below  $V_{\text{LKO}}$ .

### 25.1 Warm $\overline{\text{RESET}}$

Once the device is up and running, the PSD module can be reset with a pulse of a much shorter duration,  $t_{\text{NLNH}}$ . The same  $t_{\text{OPR}}$  period is needed before the device is operational after a Warm  $\overline{\text{RESET}}$ . *Figure 65* shows the timing of the Power-up and Warm  $\overline{\text{RESET}}$ .

### 25.2 I/O pin, register and PLD status at $\overline{\text{RESET}}$

*Table 103* shows the I/O pin, register and PLD status during Power-on  $\overline{\text{RESET}}$ , Warm  $\overline{\text{RESET}}$ , and Power-down mode. PLD outputs are always valid during Warm  $\overline{\text{RESET}}$ , and they are valid in Power-on  $\overline{\text{RESET}}$  once the internal Configuration bits are loaded. This loading is completed typically long before the  $V_{\text{CC}}$  ramps up to operating level. Once the PLD is active, the state of the outputs are determined by the PLD equations.

**Figure 65. Reset ( $\overline{\text{RESET}}$ ) timing**

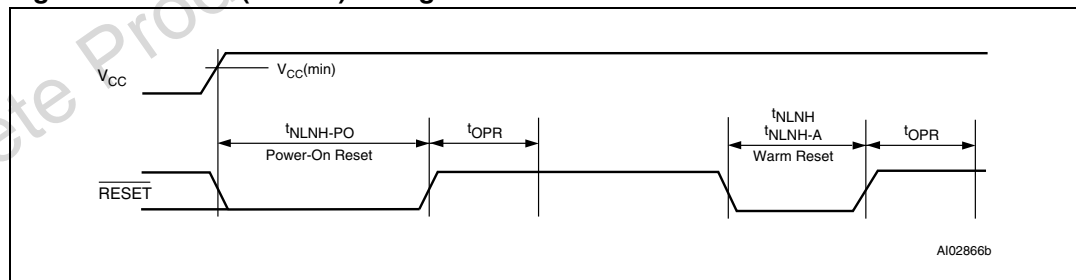

Table 103. Status during Power-on  $\overline{\text{RESET}}$ , Warm  $\overline{\text{RESET}}$  and Power-down mode

Port Configuration	Power-On $\overline{\text{RESET}}$	Warm $\overline{\text{RESET}}$	Power-down mode
MCU I/O	Input mode	Input mode	Unchanged
PLD Output	Valid after internal PSD configuration bits are loaded	Valid	Depends on inputs to PLD (addresses are blocked in PD mode)
Address Out	Tri-stated	Tri-stated	Not defined
Peripheral I/O	Tri-stated	Tri-stated	Tri-stated

Register	Power-On $\overline{\text{RESET}}$	Warm $\overline{\text{RESET}}$	Power-down mode
PMMR0 and PMMR2	Cleared to '0'	Unchanged	Unchanged
Macrocells flip-flop status	Cleared to '0' by internal Power-on $\overline{\text{RESET}}$	Depends on .re and .pr equations	Depends on .re and .pr equations
VM Register <sup>(1)</sup>	Initialized, based on the selection in PSDsoft Configuration menu	Initialized, based on the selection in PSDsoft Configuration menu	Unchanged
All other registers	Cleared to '0'	Cleared to '0'	Unchanged

1. The `SR_cod` and Periphmode Bits in the VM Register are always cleared to '0' on Power-on  $\overline{\text{RESET}}$  or Warm  $\overline{\text{RESET}}$ .

## 26 Programming in-circuit using the JTAG serial interface

The JTAG Serial Interface pins (TMS, TCK, TDI, and TDO) are dedicated pins on Port C (see [Table 104](#)). All memory blocks (primary and secondary Flash memory), PLD logic, and PSD module Configuration Register Bits may be programmed through the JTAG Serial Interface block. A blank device can be mounted on a printed circuit board and programmed using JTAG.

The standard JTAG signals (IEEE 1149.1) are TMS, TCK, TDI, and TDO. Two additional signals,  $\overline{\text{TSTAT}}$  and  $\overline{\text{TERR}}$ , are optional JTAG extensions used to speed up Program and Erase cycles.

*By default, on a blank device (as shipped from the factory or after erasure), four pins on Port C are the basic JTAG signals TMS, TCK, TDI, and TDO.*

### 26.1 Standard JTAG Signals

At power-up, the standard JTAG pins are inputs, waiting for a JTAG serial command from an external JTAG controller device (such as FlashLINK or Automated Test Equipment). When the enabling command is received, TDO becomes an output and the JTAG channel is fully functional. The same command that enables the JTAG channel may optionally enable the two additional JTAG signals,  $\overline{\text{TSTAT}}$  and  $\overline{\text{TERR}}$ .

The  $\overline{\text{RESET}}$  input to the uPS3200 should be active during JTAG programming. The active  $\overline{\text{RESET}}$  puts the MCU module into RESET mode while the PSD module is being programmed. See Application Note AN1153 for more details on JTAG In-System Programming (ISP).

UPD321xx devices support JTAG In-System-Configuration (ISC) commands, but not Boundary Scan. The PSDsoft Express software tool and FlashLINK JTAG programming cable implement the JTAG In-System-Configuration (ISC) commands.

**Table 104. JTAG port signals**

Port C Pin	JTAG Signals	Description
PC0	TMS	Mode Select
PC1	TCK	Clock
PC3	TSTAT	Status (optional)
PC4	TERR	Error Flag (optional)
PC5	TDI	Serial Data In
PC6	TDO	Serial Data Out

### 26.2 JTAG extensions

$\overline{\text{TSTAT}}$  and  $\overline{\text{TERR}}$  are two JTAG extension signals enabled by an "ISC\_ENABLE" command received over the four standard JTAG signals (TMS, TCK, TDI, and TDO). They are used to speed Program and Erase cycles by indicating status on uPDS signals instead of having to



scan the status out serially using the standard JTAG channel. See Application Note *AN1153*.

$\overline{TERR}$  indicates if an error has occurred when erasing a sector or programming a byte in Flash memory. This signal goes Low (active) when an Error condition occurs, and stays Low until an "ISC\_CLEAR" command is executed or a chip Reset ( $\overline{RESET}$ ) pulse is received after an "ISC\_DISABLE" command.

$\overline{TSTAT}$  behaves the same as Ready/ $\overline{Busy}$  described in [Section 21.2.1: Ready/Busy \(PC3\)](#).  $\overline{TSTAT}$  is High when the PSD module device is in READ mode (primary and secondary Flash memory contents can be read).  $\overline{TSTAT}$  is Low when Flash memory Program or Erase cycles are in progress, and also when data is being written to the secondary Flash memory.

$\overline{TSTAT}$  and  $\overline{TERR}$  can be configured as open-drain type signals during an "ISC\_ENABLE" command.

### 26.3 Security and Flash memory protection

When the Security Bit is set, the device cannot be read on a Device Programmer or through the JTAG Port. When using the JTAG Port, only a Full Chip Erase command is allowed.

All other Program, Erase and Verify commands are blocked. Full Chip Erase returns the part to a non-secured blank state. The Security Bit can be set in PSDsoft Express Configuration.

All primary and secondary Flash memory sectors can individually be sector protected against erasures. The sector protect bits can be set in PSDsoft Express Configuration.

## 27 Initial delivery state

When delivered from ST, the UPSD321xx devices have all bits in the memory and PLDs set to '1.' The code, configuration, and PLD logic are loaded using the programming procedure. Information for programming the device is available directly from ST. Please contact your local sales representative.

Obsolete Product(s) - Obsolete Product(s)

## 28 AC/DC parameters

These tables describe the AD and DC parameters of the UPSD321xx devices:

- DC Electrical Specification
- AC Timing Specification
- PLD Timing
  - Combinatorial Timing
  - Synchronous Clock mode
  - Asynchronous Clock mode
  - Input Macrocell Timing
- MCU module Timing
  - READ Timing
  - WRITE Timing
  - Power-down and  $\overline{\text{RESET}}$  Timing

The following are issues concerning the parameters presented:

- In the DC specification the supply current is given for different modes of operation.
- The AC power component gives the PLD, Flash memory, and SRAM mA/MHz specification. [Figure 66](#) and [Figure 67](#) show the PLD mA/MHz as a function of the number of Product Terms (PT) used.
- In the PLD timing parameters, add the required delay when Turbo Bit is '0.'

**Figure 66. PLD  $I_{CC}$ /frequency consumption (5 V range)**

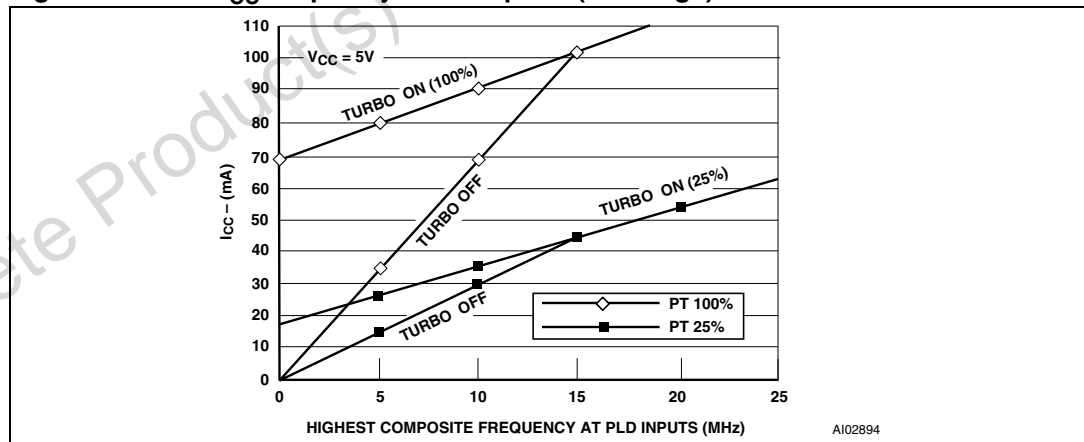

Figure 67. PLD  $I_{CC}$ /frequency consumption (3 V range)

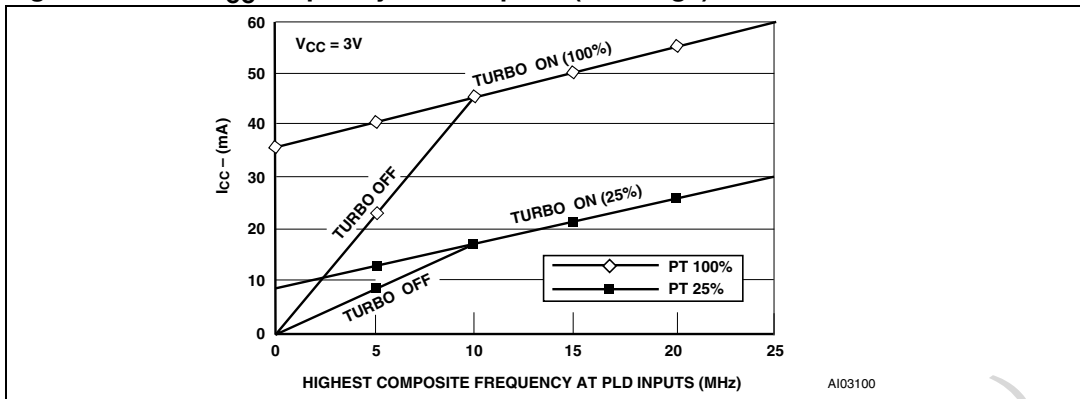

Table 105. PSD module example, typ. power calculation at  $V_{CC} = 5.0\text{ V}$  (Turbo mode off)

Conditions		
	MCU clock frequency	= 12 MHz
Highest Composite PLD input frequency		
	(Freq PLD)	= 8 MHz
MCU ALE frequency (Freq ALE)		
	= 2 MHz	
	% Flash memory access	= 80%
	% SRAM access	= 15%
	% I/O access	= 5% (no additional power above base)
Operational modes		
	% Normal	= 40%
	% Power-down mode	= 60%
Number of product terms used		
	(from fitter report)	= 45 PT
	% of total product terms	= 45/182 = 24.7%
	Turbo mode	= Off

**Table 105. PSD module example, typ. power calculation at V<sub>CC</sub> = 5.0 V (Turbo mode off) (continued)**

Conditions		
Calculation (using typical values)		
I <sub>CC</sub> total	$= I_{CC}(MCUactive) \times \%MCUactive + I_{CC}(PSDactive) \times \%PSDactive + I_{PD}(pwrdown) \times \%pwrdown$	
	I <sub>CC</sub> (MCUactive) = 20mA	
	I <sub>PD</sub> (pwrdown) = 250µA	
	I <sub>CC</sub> (PSDactive) = I <sub>CC</sub> (ac) + I <sub>CC</sub> (dc)	
	= %flash x 2.5mA/MHz x Freq ALE + %SRAM x 1.5mA/MHz x Freq ALE + % PLD x (from graph using Freq PLD)	
		= 0.8 x 2.5mA/MHz x 2MHz + 0.15 x 1.5mA/MHz x 2MHz + 24mA
		= (4 + 0.45 + 24) mA
	= 28.45mA	
	I <sub>CC</sub> total = 20mA x 40% + 28.45mA x 40% + 250µA x 60%	
		= 8mA + 11.38mA + 150µA
= 19.53mA		
This is the operating power with no Flash memory Erase or Program cycles in progress. Calculation is based on all I/O pins being disconnected and I <sub>OUT</sub> = 0mA.		

Obsolete Product(s) - Obsolete Product(s)

## 29 Maximum ratings

Stressing the device above the rating listed in the Absolute Maximum Ratings” table may cause permanent damage to the device. These are stress ratings only and operation of the device at these or any other conditions above those indicated in the Operating sections of this specification is not implied. Exposure to Absolute Maximum Rating conditions for extended periods may affect device reliability. Refer also to the STMicroelectronics SURE Program and other relevant quality documents.

**Table 106. Absolute maximum ratings**

Symbol	Parameter	Min.	Max.	Unit
T <sub>STG</sub>	Storage Temperature	-65	125	°C
T <sub>LEAD</sub>	Lead Temperature during Soldering (20 seconds max.) <sup>(1)</sup>		235	°C
V <sub>IO</sub>	Input and Output Voltage (Q = V <sub>OH</sub> or Hi-Z)	-0.5	6.5	V
V <sub>CC</sub>	Supply Voltage	-0.5	6.5	V
V <sub>PP</sub>	Device Programmer Supply Voltage	-0.5	14.0	V
V <sub>ESD</sub>	Electrostatic Discharge Voltage (Human Body Model) <sup>2</sup>	-2000	2000	V

1. IPC/JEDEC J-STD-020A

2. JEDEC Std JESD22-A114A (C1=100pF, R1=1500 Ω, R2=500 Ω)

## 30 EMC characteristics

Susceptibility test are performed on a sample basis during product characterization.

### 30.1 Functional EMS (electromagnetic susceptibility)

Based on a simple running application on the product (toggling 2 LEDs through I/O ports), the product is stressed by two electromagnetic events until a failure occurs (indicated by the LEDs).

#### 30.1.1 ESD

Electro-Static Discharge (positive and negative) is applied on all pins of the device until a functional disturbance occurs. This test conforms with the IEC 1000-4-2 Standard.

#### 30.1.2 FTB

A burst of Fast Transient voltage (positive and negative) is applied to  $V_{DD}$  and  $V_{SS}$  through a 100pF capacitor, until a functional disturbance occurs. This test conforms with the IEC 1000-4-2 Standard.

A device reset allows normal operations to be resumed. The test results are given in [Table 107](#), based on the EMS levels and classes defined in Application Note AN1709.

### 30.2 Designing hardened software to avoid noise problems

EMC characterization and optimization are performed at component level with a typical application environment and simplified MCU software. It should be noted that good EMC performance is highly dependent on the user application and the software in particular.

Therefore, it is recommended that the user applies EMC software optimization and prequalification tests in relation with the EMC level requested for the user's application.

#### 30.2.1 Software recommendations

The software flowchart must include the management of 'runaway' conditions, such as:

- Corrupted program counter
- Unexpected reset
- Critical data corruption (e.g., control registers)

#### 30.2.2 Prequalification trials

Most of the common failures (unexpected reset and program counter corruption) can be reproduced by manually forcing a low state on the RESET pin or the oscillator pins for 1 second.

To complete these trials, ESD stress can be applied directly on the device over the range of specification values. When unexpected behavior is detected, the software can be hardened to prevent unrecoverable errors occurring (see Application Note AN1015).

### 30.3 Absolute maximum ratings (electrical sensitivity)

Based on three different tests (ESD, LU, and DLU) and using specific measurement methods, the product is stressed in order to determine its performance in terms of electrical sensitivity. For more details, refer to the Application Note AN1181.

#### 30.3.1 Electro-static discharge (ESD)

Electro-Static discharges (a positive then a negative pulse separated by 1 second) are applied to the pins of each sample according to each pin combination. The sample size depends on the number of supply pins in the device (3 parts\*(n+1) supply pin). The Human Body Model is simulated ([Table 108](#)). This test complies with the JESD22-A114A Standard.

**Table 107. EMS test results**

Symbol	Parameter	Conditions	Level/Class <sup>(1)</sup>
V <sub>FESD</sub>	Voltage limits to be applied on any I/O pin to induce a functional disturbance	V <sub>DD</sub> = 4V; T <sub>A</sub> = 25°C; f <sub>OSC</sub> = 40MHz; WDT off complies with IEC 1000-4-2	3C

1. Data based on characterization results, not tested in production.

**Table 108. ESD absolute maximum ratings**

Symbol	Parameter	Conditions	Max. Value <sup>(1)</sup>	Unit
V <sub>ESD(HBM)</sub>	Electro-static discharge voltage (Human Body Model)	T <sub>A</sub> = 25°C	2000	V

1. Data based on characterization results, not tested in production

#### 30.3.2 Latch-up

3 complementary static tests are required on 10 parts to assess the latch-up performance. A supply overvoltage (applied to each power supply pin) and a current injection (applied to each input, output, and configurable I/O pin) are performed on each sample. This test conforms to the EIA/JESD 78 IC Latch-up Standard (see [Table 109](#)). For more details, refer to the Application Note, AN1181.

#### 30.3.3 Dynamic latch-up

Electro-static discharges (one positive then one negative test) are applied to each pin of 3 samples when the micro is running to assess the latch-up performance in dynamic mode. Power supplies are set to the typical values, the oscillator is connected as near as possible to the pins of the micro, and the component is put in reset mode. This test conforms to the IEC 1000-4-2 and SAEJ1752/3 Standards (see [Table 109](#)). For more details, refer to the Application Note, AN1181.

**Table 109. Latch-up and dynamic latch-up electrical sensitivities**

Symbol	Parameter	Conditions	Level/class <sup>(1)</sup>
LU	Static latch-up class	T <sub>A</sub> = 25°C	A
DLU	Dynamic latch-up class	V <sub>DD</sub> = 5 V; T <sub>A</sub> = 25°C; f <sub>OSC</sub> = 40 MHz	A

1. Class description: A Class is an STMicroelectronics internal specification. All of its limits are higher than the JEDEC specifications. This means when a device belongs to "Class A," it exceeds the JEDEC standard. "Class B" strictly covers all of the JEDEC criteria (International standards).



## 31 DC and AC parameters

This section summarizes the operating and measurement conditions, and the DC and AC characteristics of the device. The parameters in the DC and AC Characteristic tables that follow are derived from tests performed under the Measurement Conditions summarized in the relevant tables. Designers should check that the operating conditions in their circuit match the measurement conditions when relying on the quoted parameters.

**Table 110. Operating conditions (5 V devices)**

Symbol	Parameter	Min.	Max.	Unit
$V_{CC}$	Supply voltage	4.5	5.5	V
$T_A$	Ambient operating temperature (industrial)	-40	85	°C
	Ambient operating temperature (commercial)	0	70	°C

**Table 111. Operating conditions (3 V devices)**

Symbol	Parameter	Min.	Max.	Unit
$V_{CC}$	Supply voltage	3.0	3.6	V
$T_A$	Ambient operating temperature (industrial)	-40	85	°C
	Ambient operating temperature (commercial)	0	70	°C

**Table 112. AC signal letters for timing**

A	Address
C	Clock
D	Input Data
I	Instruction
L	ALE
N	$\overline{\text{RESET}}$ Input or Output
P	$\overline{\text{PSEN}}$ signal
Q	Output Data
R	RD signal
W	WR signal
M	Output Macrocell

- Example:  $t_{AVLX}$  = Time from Address Valid to ALE Invalid.

**Table 113. AC signal behavior symbols for timing**

t	Time
L	Logic Level Low or ALE
H	Logic Level High
V	Valid
X	No Longer a Valid Logic Level
Z	Float
PW	Pulse Width

1. Example:  $t_{AVLX}$  = Time from Address Valid to ALE Invalid.

**Figure 68. Switching waveforms – key**

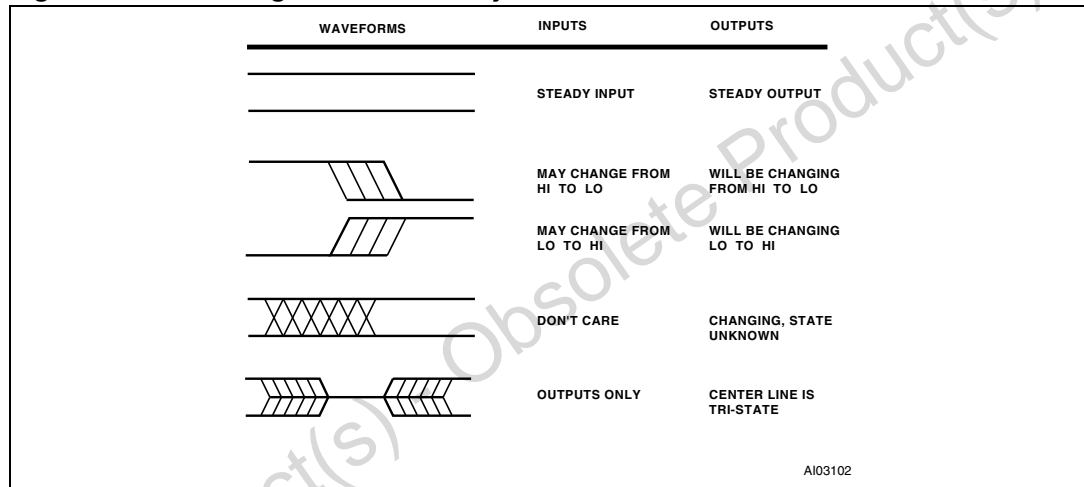

**Table 114. Major parameters**

Parameters/conditions/comments	5 V test conditions	5.0 V value	3.3 V test conditions	3.3 V value	Unit
Operating voltage	–	4.5 to 5.5	–	3.0 to 3.6	V
Operating temperature	–	–40 to 85	–	–40 to 85	°C
MCU frequency 12 MHz (min) for USB; 8 MHz (min) for I <sup>2</sup> C	–	1 Min, 40 Max	–	1 Min, 24 Max	MHz
Active current, typical (25°C operation; 80% Flash and 15% SRAM accesses, 45 PLD product terms used; PLD Turbo mode Off)	24 MHz MCU clock, 12 MHz PLD input frequency, 4 MHz ALE	72	12 MHz MCU clock, 6 MHz PLD input frequency, 2 MHz ALE	21	mA
Idle current, typical (CPU halted but some peripherals active; 25°C operation; 45 PLD product terms used; PLD Turbo mode Off)	24 MHz MCU clock, 12 MHz PLD input frequency	25	12 MHz MCU clock, 1 MHz PLD input frequency	7	mA

Table 114. Major parameters (continued)

Parameters/conditions/ comments	5 V test conditions	5.0 V value	3.3 V test conditions	3.3 V value	Unit
Standby current, typical (Power-down mode, requires reset to exit mode; without Low-Voltage Detect (LVD) Supervisor)	180 $\mu$ A with LVD	110	100 $\mu$ A with LVD	60	$\mu$ A
I/O sink/source current Ports A, B, C, and D	$V_{OL} = 0.25$ V (max); $V_{OH} = 3.9$ V (min)	$I_{OL} = 8$ (max); $I_{OH} = -2$ (min)	$V_{OL} = 0.15$ V (max); $V_{OH} = 2.6$ V (min)	$I_{OL} = 4$ (max); $I_{OH} = -1$ (min)	mA
PLD macrocells (For registered or combinatorial logic)	–	16	–	16	–
PLD inputs (Inputs from pins, macrocell feedback, or MCU addresses)	–	69	–	69	–
PLD outputs (Output to pins or internal feedback)	–	16	–	16	–
PLD propagation delay, typical (PLD input to output, Turbo mode)	–	15	–	22	ns

Table 115. DC characteristics (5 V devices)

Symbol	Parameter	Test conditions (in addition to those in Table 110)	Min.	Typ.	Max.	Unit
$V_{IH}$	Input high voltage (Ports 1, 2, 3, 4[Bits 7,6,5,4,3,1,0], XTAL1, RESET)	$4.5\text{ V} < V_{CC} < 5.5\text{ V}$	$0.7 V_{CC}$		$V_{CC} + 0.5$	V
$V_{IH1}$	Input high voltage (Ports A, B, C, D, 4[Bit 2], USB+, USB-)	$4.5\text{ V} < V_{CC} < 5.5\text{ V}$	2.0		$V_{CC} + 0.5$	V
$V_{IL}$	Input low voltage (Ports 1, 2, 3, 4[Bits 7,6,5,4,3,1,0], XTAL1, RESET)	$4.5\text{ V} < V_{CC} < 5.5\text{ V}$	$V_{SS} - 0.5$		$0.3 V_C$	V
$V_{IL1}$	Input low voltage (Ports A, B, C, D, 4[Bit 2])	$4.5\text{ V} < V_{CC} < 5.5\text{ V}$	-0.5		0.8	V
	Input low voltage (USB+, USB-)	$4.5\text{ V} < V_{CC} < 5.5\text{ V}$	$V_{SS} - 0.5$		0.8	V
$V_{OL}$	Output low voltage (Ports A,B,C,D)	$I_{OL} = 20\text{ }\mu\text{A}$ $V_{CC} = 4.5\text{ V}$		0.01	0.1	V
		$I_{OL} = 8\text{ mA}$ $V_{CC} = 4.5\text{ V}$		0.25	0.45	V
$V_{OL1}$	Output low voltage (Ports 1,2,3,4, $\overline{WR}$ , $\overline{RD}$ )	$I_{OL} = 1.6\text{ mA}$			0.45	V
$V_{OL2}$	Output low voltage (Port 0, ALE, PSEN)	$I_{OL} = 3.2\text{ mA}$			0.45	V
$V_{OH}$	Output high voltage (Ports A,B,C,D)	$I_{OH} = -20\text{ }\mu\text{A}$ $V_{CC} = 4.5\text{ V}$	4.4	4.49		V
		$I_{OH} = -2\text{ mA}$ $V_{CC} = 4.5\text{ V}$	2.4	3.9		V
$V_{OH2}$	Output high voltage (Port 0 in ext. Bus mode, ALE, PSEN)	$I_{OH} = -800\text{ }\mu\text{A}$	2.4			V
		$I_{OH} = -80\text{ }\mu\text{A}$	4.05			V
$V_{LVR}$	Low Voltage $\overline{RESET}$	0.1 V hysteresis	3.75	4.0	4.25	V
$V_{OP}$	XTAL open bias voltage (XTAL1, XTAL2)	$I_{OL} = 3.2\text{ mA}$	2.0		3.0	V
$V_{LKO}$	$V_{CC}(\text{min})$ for Flash Erase and Program		2.5		4.2	V
$I_{IL}$	Logic '0' input current (Ports 1,2,3,4)	$V_{IN} = 0.45\text{ V}$ (0 V for Port 4[pin 2])	-10		-50	$\mu\text{A}$
$I_{TL}$	Logic 1-to-0 transition current (Ports 1,2,3,4)	$V_{IN} = 3.5\text{ V}$ (2.5 V for Port 4[pin 2])	-65		-650	$\mu\text{A}$
$I_{RST}$	Reset pin pull-up current ( $\overline{RESET}$ )	$V_{IN} = V_{SS}$	-10		-55	$\mu\text{A}$

Table 115. DC characteristics (5 V devices) (continued)

Symbol	Parameter		Test conditions (in addition to those in Table 110)	Min.	Typ.	Max.	Unit
$I_{FR}$	XTAL feedback resistor current (XTAL1)		XTAL1 = $V_{CC}$ XTAL2 = $V_{SS}$	-20		-50	$\mu A$
$I_{LI}$	Input leakage current		$V_{SS} < V_{IN} < V_{CC}$	-1		1	$\mu A$
$I_{LO}$	Output leakage current		$0.45 < V_{OUT} < V_{CC}$	-10		10	$\mu A$
$I_{PD}^{(1)}$	Power-down mode		$V_{CC} = 5.5 V$ LVD logic disabled			250	$\mu A$
			LVD logic enabled			380	$\mu A$
$I_{CC\_CPU}^{(2,3,6)}$	Active (12 MHz)		$V_{CC} = 5 V$		20	30	mA
	Idle (12 MHz)				8	10	mA
	Active (24 MHz)		$V_{CC} = 5 V$		30	38	mA
	Idle (24 MHz)				15	20	mA
	Active (40 MHz)		$V_{CC} = 5 V$		40	62	mA
	Idle (40 MHz)				20	30	mA
$I_{CC\_PSD}^{(DC)(6)}$	Operating supply current	PLD Only	PLD_TURBO = Off, $f = 0 MHz^{(4)}$		0		$\mu A/PT^{(5)}$
			PLD_TURBO = On, $f = 0 MHz$		400	700	$\mu A/PT$
		Flash memory	During Flash memory WRITE/Erase Only		15	30	mA
			Read-only, $f = 0 MHz$		0	0	mA
	SRAM	$f = 0 MHz$		0	0	mA	
$I_{CC\_PSD}^{(AC)(6)}$	PLD AC Base			Note 5			
	Flash memory AC adder				2.5	3.5	mA/MHz
	SRAM AC adder				1.5	3.0	mA/MHz

- $I_{PD}$  (Power-down mode) is measured with:  
XTAL1= $V_{SS}$ ; XTAL2=not connected;  $\overline{RESET}=V_{CC}$ ; Port 0= $V_{CC}$ ; all other pins are disconnected. PLD not in Turbo mode.
- $I_{CC\_CPU}$  (active mode) is measured with:  
XTAL1 driven with  $t_{CLCH}, t_{CHCL} = 5 ns, V_{IL} = V_{SS}+0.5 V, V_{IH} = V_{CC} - 0.5 V, XTAL2 = not connected;$   
 $\overline{RESET}=V_{SS}$ ; Port 0= $V_{CC}$ ; all other pins are disconnected.  $I_{CC}$  would be slightly higher if a crystal oscillator is used (approximately 1mA).
- $I_{CC\_CPU}$  (Idle mode) is measured with:  
XTAL1 driven with  $t_{CLCH}, t_{CHCL} = 5 ns, V_{IL} = V_{SS}+0.5 V, V_{IH} = V_{CC} - 0.5 V, XTAL2 = not connected;$   
Port 0 =  $V_{CC}$ ;
- $\overline{RESET}=V_{CC}$ ; all other pins are disconnected.
- PLD is in non-Turbo mode and none of the inputs are switching.
- See Figure 66 for the PLD current calculation.
- I/O current = 0 mA, all I/O pins are disconnected.

Table 116. DC characteristics (3 V devices)

Symbol	Parameter	Test conditions (in addition to those in Table 111)	Min.	Typ.	Max.	Unit
$V_{IH}$	Input high voltage (Ports 1, 2, 3, 4[Bits 7,6,5,4,3,1,0], A, B, C, D, XTAL1, RESET)	$3.0\text{ V} < V_{CC} < 3.6\text{ V}$	$0.7V_{CC}$		$V_{CC} + 0.5$	V
$V_{IH1}$	Input high voltage (Port 4[Bit 2])	$3.0\text{ V} < V_{CC} < 3.6\text{ V}$	2.0		$V_{CC} + 0.5$	V
$V_{IL}$	Input low voltage (Ports 1, 2, 3, 4[Bits 7,6,5,4,3,1,0], XTAL1, RESET)	$3.0\text{ V} < V_{CC} < 3.6\text{ V}$	$V_{SS} - 0.5$		$0.3 V_{CC}$	V
$V_{IL1}$	Input low voltage (Ports A, B, C, D)	$3.0\text{ V} < V_{CC} < 3.6\text{ V}$	-0.5		0.8	V
	Input low voltage (Port 4[Bit 2])	$3.0\text{ V} < V_{CC} < 3.6\text{ V}$	$V_{SS} - 0.5$		0.8	V
$V_{OL}$	Output low voltage (Ports A,B,C,D)	$I_{OL} = 20\text{ }\mu\text{A}$ $V_{CC} = 3.0\text{ V}$		0.01	0.1	V
		$I_{OL} = 4\text{ mA}$ $V_{CC} = 3.0\text{ V}$		0.15	0.45	V
$V_{OL1}$	Output low voltage (Ports 1,2,3,4, $\overline{WR}$ , $\overline{RD}$ )	$I_{OL} = 1.6\text{ mA}$			0.45	V
		$I_{OL} = 100\text{ }\mu\text{A}$			0.3	V
$V_{OL2}$	Output low voltage (Port 0, ALE, PSEN)	$I_{OL} = 3.2\text{ mA}$			0.45	V
		$I_{OL} = 200\text{ }\mu\text{A}$			0.3	V
$V_{OH}$	Output high voltage (Ports A,B,C,D)	$I_{OH} = -20\text{ }\mu\text{A}$ $V_{CC} = 3.0\text{ V}$	2.9	2.99		V
		$I_{OH} = -1\text{ mA}$ $V_{CC} = 3.0\text{ V}$	2.4	2.6		V
$V_{OH2}$	Output high voltage (Port 0 in ext. Bus mode, ALE, PSEN)	$I_{OH} = -800\text{ }\mu\text{A}$	2.0			V
		$I_{OH} = -80\text{ }\mu\text{A}$	2.7			V
$V_{LVR}$	Low voltage reset	0.1 V hysteresis	2.3	2.5	2.7	V
$V_{OP}$	XTAL open bias voltage (XTAL1, XTAL2)	$I_{OL} = 3.2\text{ mA}$	1.0		2.0	V
$V_{LKO}$	$V_{CC}(\text{min})$ for Flash Erase and Program		1.5		2.2	V
$I_{IL}$	Logic '0' input current (Ports 1,2,3,4)	$V_{IN} = 0.45\text{ V}$ (0 V for Port 4[pin 2])	-1		-50	$\mu\text{A}$
$I_{TL}$	Logic 1-to-0 transition current (Ports 1,2,3,4)	$V_{IN} = 3.5\text{ V}$ (2.5 V for Port 4[pin 2])	-25		-250	$\mu\text{A}$
$I_{RST}$	Reset pin pull-up current (RESET)	$V_{IN} = V_{SS}$	-10		-55	$\mu\text{A}$
$I_{FR}$	XTAL feedback resistor current (XTAL1)	XTAL1 = $V_{CC}$ XTAL2 = $V_{SS}$	-20		-50	$\mu\text{A}$
$I_{LI}$	Input leakage current	$V_{SS} < V_{IN} < V_{CC}$	-1		1	$\mu\text{A}$
$I_{LO}$	Output leakage current	$0.45 < V_{OUT} < V_{CC}$	-10		10	$\mu\text{A}$

**Table 116. DC characteristics (3 V devices) (continued)**

Symbol	Parameter		Test conditions (in addition to those in <a href="#">Table 111</a> )	Min.	Typ.	Max.	Unit
$I_{PD}^{(1)}$	Power-down mode		$V_{CC} = 3.6\text{ V}$ LVD logic disabled			110	$\mu\text{A}$
			LVD logic enabled			180	$\mu\text{A}$
$I_{CC\_CPU}^{(2,3,6)}$	Active (12 MHz)		$V_{CC} = 3.6\text{ V}$		8	10	mA
	Idle (12 MHz)				4	5	mA
	Active (24 MHz)		$V_{CC} = 3.6\text{ V}$		15	20	mA
	Idle (24 MHz)				8	10	mA
$I_{CC\_PSD}^{(DC)}^{(6)}$	Operating supply current	PLD Only	PLD_TURBO = Off, $f = 0\text{ MHz}^{(4)}$		0		$\mu\text{A/PT}^{(5)}$
			PLD_TURBO = On, $f = 0\text{ MHz}$		200	400	$\mu\text{A/PT}$
		Flash memory	During Flash memory WRITE/Erase Only		10	25	mA
			Read-only, $f = 0\text{ MHz}$		0	0	mA
		SRAM	$f = 0\text{ MHz}$		0	0	mA
$I_{CC\_PSD}^{(AC)}^{(6)}$	PLD AC base			Note 5			
	Flash memory AC adder				1.5	2.0	mA/MHz
	SRAM AC adder				0.8	1.5	mA/MHz

- $I_{PD}$  (Power-down mode) is measured with:  
XTAL1= $V_{SS}$ ; XTAL2=not connected;  $\overline{\text{RESET}}=V_{CC}$ ; Port 0= $V_{CC}$ ; all other pins are disconnected. PLD not in Turbo mode.
- $I_{CC\_CPU}$  (active mode) is measured with:  
XTAL1 driven with  $t_{CLCH}$ ,  $t_{CHCL} = 5\text{ ns}$ ,  $V_{IL} = V_{SS}+0.5\text{ V}$ ,  $V_{IH} = V_{CC} - 0.5\text{ V}$ , XTAL2 = not connected;  
 $\overline{\text{RESET}}=V_{SS}$ ; Port 0= $V_{CC}$ ; all other pins are disconnected.  $I_{CC}$  would be slightly higher if a crystal oscillator is used (approximately 1 mA).
- $I_{CC\_CPU}$  (Idle mode) is measured with:  
XTAL1 driven with  $t_{CLCH}$ ,  $t_{CHCL} = 5\text{ ns}$ ,  $V_{IL} = V_{SS}+0.5\text{ V}$ ,  $V_{IH} = V_{CC} - 0.5\text{ V}$ , XTAL2 = not connected;  
Port 0 =  $V_{CC}$ ;
- $\overline{\text{RESET}} = V_{CC}$ ; all other pins are disconnected.
- PLD is in non-Turbo mode and none of the inputs are switching.
- See [Figure 66](#) for the PLD current calculation.
- I/O current = 0 mA, all I/O pins are disconnected.

Figure 69. External program memory Read cycle

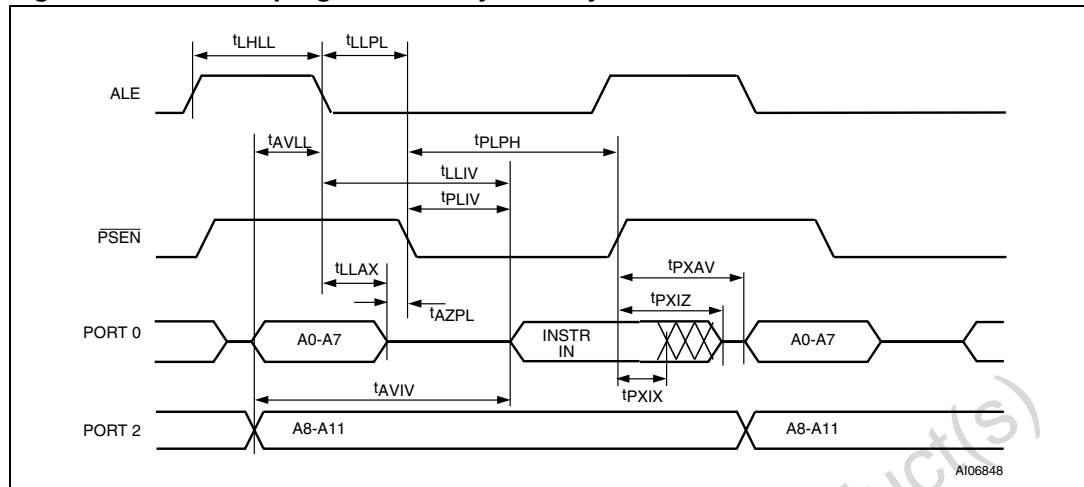

Table 117. External program memory AC characteristics (with the 5 V MCU module)

Symbol	Parameter <sup>(1)</sup>	40 MHz oscillator		Variable oscillator 1/t <sub>CLCL</sub> = 24 to 40 MHz		Unit
		Min.	Max.	Min.	Max.	
t <sub>LHLL</sub>	ALE pulse width	35		2 t <sub>CLCL</sub> - 15		ns
t <sub>AVLL</sub>	Address set-up to ALE	10		t <sub>CLCL</sub> - 15		ns
t <sub>LLAX</sub>	Address hold after ALE	10		t <sub>CLCL</sub> - 15		ns
t <sub>LLIV</sub>	ALE Low to valid instruction in		55		4 t <sub>CLCL</sub> - 45	ns
t <sub>LLPL</sub>	ALE to PSEN	10		t <sub>CLCL</sub> - 15		ns
t <sub>PLPH</sub>	PSEN pulse width	60		3 t <sub>CLCL</sub> - 15		ns
t <sub>PLIV</sub>	PSEN to valid instruction in		30		3 t <sub>CLCL</sub> - 45	ns
t <sub>PXIX</sub>	Input instruction hold after PSEN	0		0		ns
t <sub>PXIZ</sub> <sup>(2)</sup>	Input instruction float after PSEN		15		t <sub>CLCL</sub> - 10	ns
t <sub>PXAV</sub> <sup>(2)</sup>	Address valid after PSEN	20		t <sub>CLCL</sub> - 5		ns
t <sub>AVIV</sub>	Address to valid instruction in		70		5 t <sub>CLCL</sub> - 55	ns
t <sub>AZPL</sub>	Address float to PSEN	-5		-5		ns

1. Conditions (in addition to those in Table 110, V<sub>CC</sub> = 4.5 to 5.5 V): V<sub>SS</sub> = 0 V; C<sub>L</sub> for Port 0, ALE and PSEN output is 100 pF; C<sub>L</sub> for other outputs is 80 pF
2. Interfacing the UPSD321xx devices to devices with float times up to 20 ns is permissible. This limited bus contention does not cause any damage to Port 0 drivers.



**Table 118. External program memory AC characteristics (with the 3 V MCU module)**

Symbol	Parameter <sup>(1)</sup>	24 MHz oscillator		Variable oscillator 1/t <sub>CLCL</sub> = 8 to 24 MHz		Unit
		Min.	Max.	Min.	Max.	
t <sub>LHLL</sub>	ALE pulse width	43		2 t <sub>CLCL</sub> - 40		ns
t <sub>AVLL</sub>	Address set-up to ALE	17		t <sub>CLCL</sub> - 25		ns
t <sub>LLAX</sub>	Address hold after ALE	17		t <sub>CLCL</sub> - 25		ns
t <sub>LLIV</sub>	ALE Low to valid instruction in		80		4 t <sub>CLCL</sub> - 87	ns
t <sub>LLPL</sub>	ALE to PSEN	22		t <sub>CLCL</sub> - 20		ns
t <sub>PLPH</sub>	PSEN pulse width	95		3 t <sub>CLCL</sub> - 30		ns
t <sub>PLIV</sub>	PSEN to valid instruction in		60		3 t <sub>CLCL</sub> - 65	ns
t <sub>PXIX</sub>	Input instruction hold after PSEN	0		0		ns
t <sub>PXIZ</sub> <sup>(2)</sup>	Input instruction float after PSEN		32		t <sub>CLCL</sub> - 10	ns
t <sub>PXAV</sub> <sup>(2)</sup>	Address valid after PSEN	37		t <sub>CLCL</sub> - 5		ns
t <sub>AVIV</sub>	Address to valid instruction in		148		5 t <sub>CLCL</sub> - 60	ns
t <sub>AZPL</sub>	Address float to PSEN	-10		-10		ns

1. Conditions (in addition to those in [Table 111](#), V<sub>CC</sub> = 3.0 to 3.6 V): V<sub>SS</sub> = 0 V; C<sub>L</sub> for Port 0, ALE and PSEN output is 100 pF, for 5 V devices, and 50 pF for 3 V devices; C<sub>L</sub> for other outputs is 80 pF, for 5 V devices, and 50 pF for 3 V devices)
2. Interfacing the UPSD321xx devices to devices with float times up to 35 ns is permissible. This limited bus contention does not cause any damage to Port 0 drivers.

**Table 119. External clock drive (with the 5 V MCU module)**

Symbol	Parameter <sup>(1)</sup>	40 MHz oscillator		Variable oscillator 1/t <sub>CLCL</sub> = 24 to 40 MHz		Unit
		Min.	Max.	Min.	Max.	
t <sub>RLRH</sub>	Oscillator period			25	41.7	ns
t <sub>WLWH</sub>	High time			10	t <sub>CLCL</sub> - t <sub>CLCX</sub>	ns
t <sub>LLAX2</sub>	Low time			10	t <sub>CLCL</sub> - t <sub>CLCX</sub>	ns
t <sub>RHDX</sub>	Rise time				10	ns
t <sub>RHDX</sub>	Fall time				10	ns

1. Conditions (in addition to those in [Table 110](#), V<sub>CC</sub> = 4.5 to 5.5 V): V<sub>SS</sub> = 0 V; C<sub>L</sub> for Port 0, ALE and PSEN output is 100 pF; C<sub>L</sub> for other outputs is 80 pF

**Table 120. External clock drive (with the 3 V MCU module)**

Symbol	Parameter <sup>(1)</sup>	24 MHz oscillator		Variable oscillator 1/t <sub>CLCL</sub> = 8 to 24 MHz		Unit
		Min.	Max.	Min.	Max.	
t <sub>RLRH</sub>	Oscillator period			41.7	125	ns
t <sub>WLWH</sub>	High time			12	t <sub>CLCL</sub> - t <sub>CLCX</sub>	ns
t <sub>LLAX2</sub>	Low time			12	t <sub>CLCL</sub> - t <sub>CLCX</sub>	ns
t <sub>RHDX</sub>	Rise time				12	ns
t <sub>RHDX</sub>	Fall time				12	ns

1. Conditions (in addition to those in Table 111, V<sub>CC</sub> = 3.0 to 3.6 V): V<sub>SS</sub> = 0 V; C<sub>L</sub> for Port 0, ALE and PSEN output is 100 pF, for 5 V devices, and 50 pF for 3 V devices; C<sub>L</sub> for other outputs is 80 pF, for 5 V devices, and 50 pF for 3 V devices)

**Figure 70. External data memory Read cycle**

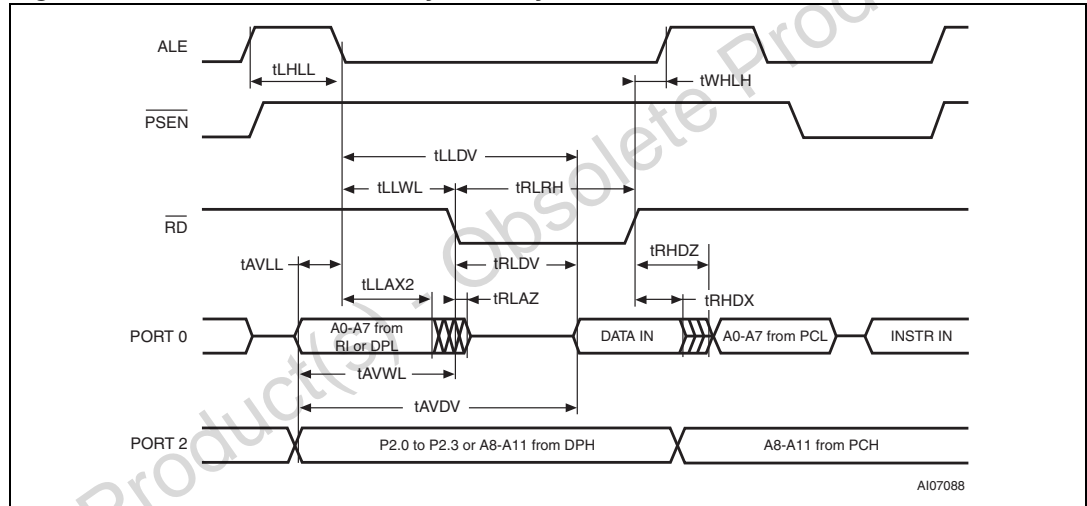

**Figure 71. External data memory Write cycle**

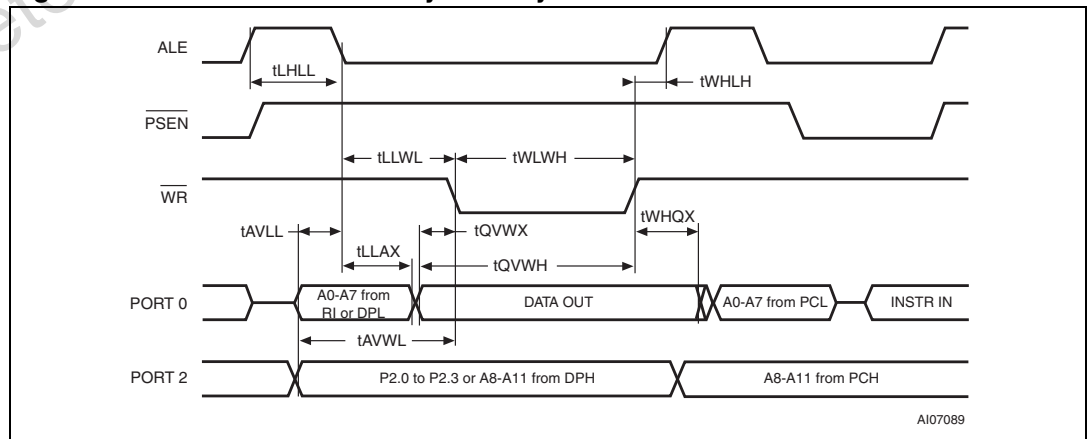

Table 121. External data memory AC characteristics (with the 5 V MCU module)

Symbol	Parameter <sup>(1)</sup>	40 MHz oscillator		Variable oscillator 1/t <sub>CLCL</sub> = 24 to 40 MHz		Unit
		Min.	Max.	Min.	Max.	
t <sub>RLRH</sub>	$\overline{RD}$ pulse width	120		6 t <sub>CLCL</sub> - 30		ns
t <sub>WLWH</sub>	$\overline{WR}$ pulse width	120		6 t <sub>CLCL</sub> - 30		ns
t <sub>LLAX2</sub>	Address hold after ALE	10		t <sub>CLCL</sub> - 15		ns
t <sub>RHDX</sub>	$\overline{RD}$ to valid data in		75		5 t <sub>CLCL</sub> - 50	ns
t <sub>RHDX</sub>	Data hold after $\overline{RD}$	0		0		ns
t <sub>RHDZ</sub>	Data float after $\overline{RD}$		38		2 t <sub>CLCL</sub> - 12	ns
t <sub>LLDV</sub>	ALE to valid data in		150		8 t <sub>CLCL</sub> - 50	ns
t <sub>AVDV</sub>	Address to valid data in		150		9 t <sub>CLCL</sub> - 75	ns
t <sub>LLWL</sub>	ALE to $\overline{WR}$ or $\overline{RD}$	60	90	3 t <sub>CLCL</sub> - 15	t <sub>CLCL</sub> + 15	ns
t <sub>AVWL</sub>	Address valid to $\overline{WR}$ or $\overline{RD}$	70		4 t <sub>CLCL</sub> - 30		ns
t <sub>WHLH</sub>	$\overline{WR}$ or $\overline{RD}$ High to ALE High	10	40	t <sub>CLCL</sub> - 15	t <sub>CLCL</sub> + 15	ns
t <sub>QVWX</sub>	Data valid to $\overline{WR}$ transition	5		t <sub>CLCL</sub> - 20		ns
t <sub>QVWH</sub>	Data set-up before $\overline{WR}$	125		7 t <sub>CLCL</sub> - 50		ns
t <sub>WHQX</sub>	Data hold after $\overline{WR}$	5		t <sub>CLCL</sub> - 20		ns
t <sub>RLAZ</sub>	Address float after $\overline{RD}$		0		0	ns

1. Conditions (in addition to those in Table 110, V<sub>CC</sub> = 4.5 to 5.5 V): V<sub>SS</sub> = 0 V; C<sub>L</sub> for Port 0, ALE and PSEN output is 100 pF; C<sub>L</sub> for other outputs is 80 pF

**Table 122. External data memory AC characteristics (with the 3 V MCU module)**

Symbol	Parameter <sup>(1)</sup>	24 MHz oscillator		Variable oscillator 1/t <sub>CLCL</sub> = 8 to 24 MHz		Unit
		Min.	Max.	Min.	Max.	
t <sub>RLRH</sub>	$\overline{RD}$ pulse width	180		6 t <sub>CLCL</sub> - 70		ns
t <sub>WLWH</sub>	$\overline{WR}$ pulse width	180		6 t <sub>CLCL</sub> - 70		ns
t <sub>LLAX2</sub>	Address hold after ALE	56		2 t <sub>CLCL</sub> - 27		ns
t <sub>RHDX</sub>	$\overline{RD}$ to valid data in		118		5 t <sub>CLCL</sub> - 90	ns
t <sub>RHDX</sub>	Data hold after $\overline{RD}$	0		0		ns
t <sub>RHDZ</sub>	Data float after $\overline{RD}$		63		2 t <sub>CLCL</sub> - 20	ns
t <sub>LLDV</sub>	ALE to valid data in		200		8 t <sub>CLCL</sub> - 133	ns
t <sub>AVDV</sub>	Address to valid data in		220		9 t <sub>CLCL</sub> - 155	ns
t <sub>LLWL</sub>	ALE to $\overline{WR}$ or $\overline{RD}$	75	175	3 t <sub>CLCL</sub> - 50	t <sub>CLCL</sub> + 50	ns
t <sub>AVWL</sub>	Address valid to $\overline{WR}$ or $\overline{RD}$	67		4 t <sub>CLCL</sub> - 97		ns
t <sub>WHLH</sub>	$\overline{WR}$ or $\overline{RD}$ High to ALE High	17	67	t <sub>CLCL</sub> - 25	t <sub>CLCL</sub> + 25	ns
t <sub>QVWX</sub>	Data valid to $\overline{WR}$ transition	5		t <sub>CLCL</sub> - 37		ns
t <sub>QVWH</sub>	Data set-up before $\overline{WR}$	170		7 t <sub>CLCL</sub> - 122		ns
t <sub>WHQX</sub>	Data hold after $\overline{WR}$	15		t <sub>CLCL</sub> - 27		ns
t <sub>RLAZ</sub>	Address float after $\overline{RD}$		0		0	ns

1. Conditions (in addition to those in [Table 111](#), V<sub>CC</sub> = 3.0 to 3.6 V): V<sub>SS</sub> = 0 V; C<sub>I</sub> for Port 0, ALE and PSEN output is 100 pF, for 5 V devices, and 50 pF for 3 V devices; C<sub>L</sub> for other outputs is 80 pF, for 5 V devices, and 50 pF for 3 V devices)

**Table 123. A/D analog specification**

Symbol	Parameter	Test condition	Min.	Typ.	Max.	Unit
AV <sub>REF</sub>	Analog power supply input voltage range		V <sub>SS</sub>		V <sub>CC</sub>	V
V <sub>AN</sub>	Analog input voltage range		V <sub>SS</sub> - 0.3		AV <sub>REF</sub> + 0.3	V
I <sub>AVDD</sub>	Current following between V <sub>CC</sub> and V <sub>SS</sub>				200	μA
CA <sub>IN</sub>	Overall accuracy				±2	l.s.b.
N <sub>NLE</sub>	Non-linearity error				±2	l.s.b.
N <sub>DNLE</sub>	Differential non-linearity error				±2	l.s.b.
N <sub>ZOE</sub>	Zero-offset error				±2	l.s.b.
N <sub>FSE</sub>	Full scale error				±2	l.s.b.
N <sub>GE</sub>	Gain error				±2	l.s.b.
t <sub>CONV</sub>	Conversion time	at 8 MHz clock			20	μs

Figure 72. Input to output disable / enable

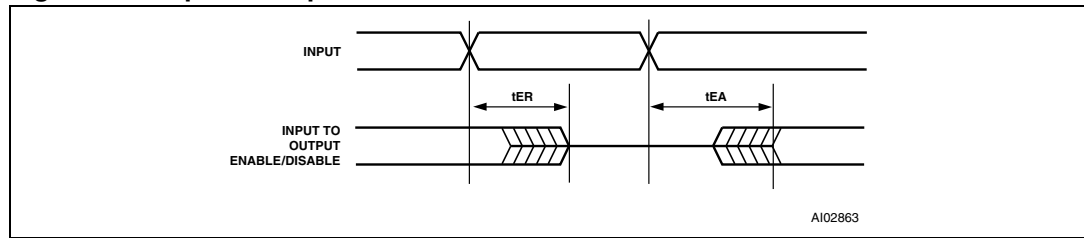

Table 124. CPLD combinatorial timing (5 V devices)

Symbol	Parameter	Conditions	Min.	Max.	PT alloc	Turbo off	Slew rate <sup>(1)</sup>	Unit
$t_{PD}^{(2)}$	CPLD input pin/feedback to CPLD combinatorial output			20	+ 2	+ 10	- 2	ns
$t_{EA}$	CPLD input to CPLD output enable			21		+ 10	- 2	ns
$t_{ER}$	CPLD input to CPLD output disable			21		+ 10	- 2	ns
$t_{ARP}$	CPLD register clear or preset delay			21		+ 10	- 2	ns
$t_{ARPW}$	CPLD register clear or preset pulse width		10			+ 10		ns
$t_{ARD}$	CPLD array delay	Any macrocell		11	+ 2			ns

1. Fast Slew Rate output available on PA3-PA0, PB3-PB0, and PD2-PD1. Decrement times by given amount
2.  $t_{PD}$  for MCU address and control signals refers to delay from pins on Port 0, Port 2,  $\overline{RD}$ ,  $\overline{WR}$ ,  $\overline{PSEN}$  and  $\overline{ALE}$  to CPLD combinatorial output (80-pin package only)

Table 125. CPLD combinatorial timing (3 V devices)

Symbol	Parameter	Conditions	Min.	Max.	PT alloc	Turbo off	Slew rate <sup>(1)</sup>	Unit
$t_{PD}^{(2)}$	CPLD input pin/feedback to CPLD combinatorial output			40	+ 4	+ 20	- 6	ns
$t_{EA}$	CPLD input to CPLD output enable			43		+ 20	- 6	ns
$t_{ER}$	CPLD input to CPLD output disable			43		+ 20	- 6	ns
$t_{ARP}$	CPLD register clear or preset delay			40		+ 20	- 6	ns
$t_{ARPW}$	CPLD register clear or preset pulse width		25			+ 20		ns
$t_{ARD}$	CPLD array delay	Any macrocell		25	+ 4			ns

1. Fast Slew Rate output available on PA3-PA0, PB3-PB0, and PD2-PD1. Decrement times by given amount
2.  $t_{PD}$  for MCU address and control signals refers to delay from pins on Port 0, Port 2,  $\overline{RD}$ ,  $\overline{WR}$ ,  $\overline{PSEN}$  and  $\overline{ALE}$  to CPLD combinatorial output (80-pin package only)

Figure 73. Synchronous clock mode timing – PLD

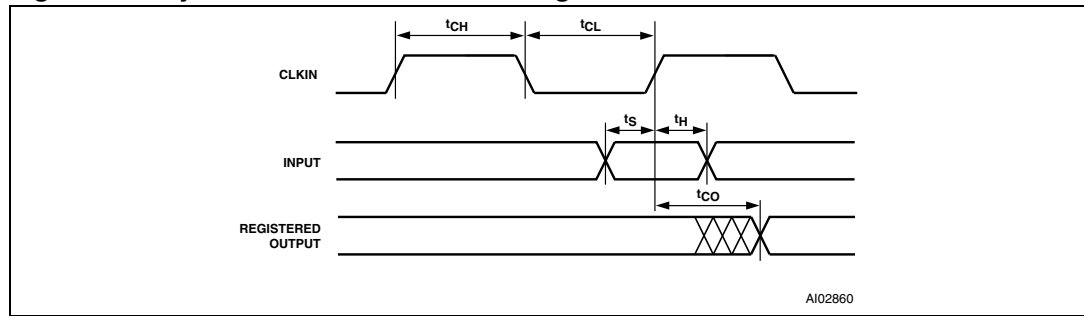

Table 126. CPLD macrocell synchronous clock mode timing (5 V devices)

Symbol	Parameter	Conditions	Min.	Max.	PT Alloc	Turbo Off	Slew rate <sup>(1)</sup>	Unit
f <sub>MAX</sub>	Maximum frequency external feedback	1/(t <sub>S</sub> +t <sub>CO</sub> )		40.0				MHz
	Maximum frequency internal feedback (f <sub>CNT</sub> )	1/(t <sub>S</sub> +t <sub>CO</sub> -10)		66.6				MHz
	Maximum frequency pipelined data	1/(t <sub>CH</sub> +t <sub>CL</sub> )		83.3				MHz
t <sub>S</sub>	Input setup time		12		+ 2	+ 10		ns
t <sub>H</sub>	Input hold time		0					ns
t <sub>CH</sub>	Clock high time	Clock input	6					ns
t <sub>CL</sub>	Clock low time	Clock input	6					ns
t <sub>CO</sub>	Clock to output delay	Clock input		13			- 2	ns
t <sub>ARD</sub>	CPLD array delay	Any macrocell		11	+ 2			ns
t <sub>MIN</sub>	Minimum clock period <sup>(2)</sup>	t <sub>CH</sub> +t <sub>CL</sub>	12					ns

1. Fast Slew Rate output available on PA3-PA0, PB3-PB0, and PD2-PD1. Decrement times by given amount.

2. CLKIN (PD1) t<sub>CLCL</sub> = t<sub>CH</sub> + t<sub>CL</sub>.

Table 127. CPLD macrocell synchronous clock mode timing (3 V devices)

Symbol	Parameter	Conditions	Min.	Max.	PT aloc	Turbo off	Slew rate (1)	Unit
f <sub>MAX</sub>	Maximum frequency external feedback	1/(t <sub>S</sub> +t <sub>CO</sub> )		22.2				MHz
	Maximum frequency internal feedback (f <sub>CNT</sub> )	1/(t <sub>S</sub> +t <sub>CO</sub> -10)		28.5				MHz
	Maximum frequency pipelined data	1/(t <sub>CH</sub> +t <sub>CL</sub> )		40.0				MHz
t <sub>S</sub>	Input setup time		20		+ 4	+ 20		ns
t <sub>H</sub>	Input hold time		0					ns
t <sub>CH</sub>	Clock high time	Clock input	15					ns
t <sub>CL</sub>	Clock low time	Clock input	10					ns
t <sub>CO</sub>	Clock to output delay	Clock input		25			- 6	ns
t <sub>ARD</sub>	CPLD array delay	Any macrocell		25	+ 4			ns
t <sub>MIN</sub>	Minimum clock period (2)	t <sub>CH</sub> +t <sub>CL</sub>	25					ns

1. Fast Slew Rate output available on PA3-PA0, PB3-PB0, and PD2-PD1. Decrement times by given amount.
2. CLKIN (PD1) t<sub>CLCL</sub> = t<sub>CH</sub> + t<sub>CL</sub>.

Figure 74. Asynchronous Reset / Preset

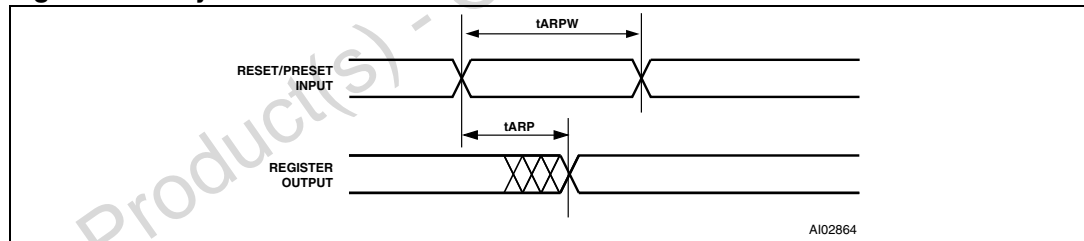
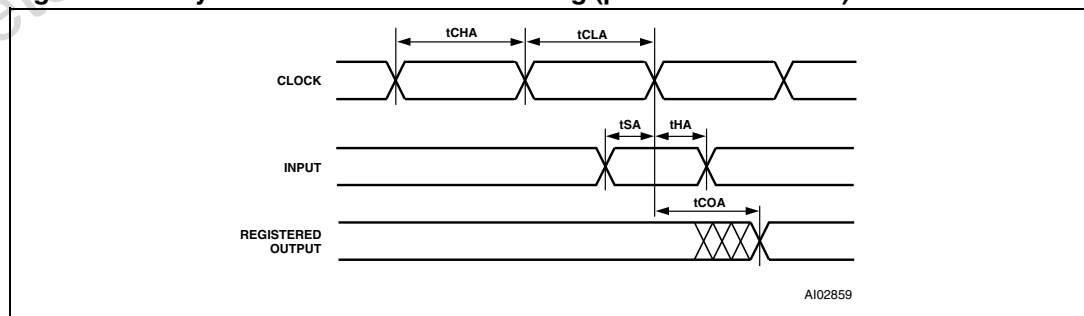

Figure 75. Asynchronous clock mode timing (product term clock)



**Table 128. CPLD macrocell asynchronous clock mode timing (5 V devices)**

Symbol	Parameter	Conditions	Min	Max	PT aloc	Turbo off	Slew rate	Unit
f <sub>MAXA</sub>	Maximum frequency external feedback	1/(t <sub>SA</sub> +t <sub>COA</sub> )		38.4				MHz
	Maximum frequency internal feedback (f <sub>CNTA</sub> )	1/(t <sub>SA</sub> +t <sub>COA</sub> -10)		62.5				MHz
	Maximum frequency pipelined data	1/(t <sub>CHA</sub> +t <sub>CLA</sub> )		71.4				MHz
t <sub>SA</sub>	Input setup time		7		+ 2	+ 10		ns
t <sub>HA</sub>	Input hold time		8					ns
t <sub>CHA</sub>	Clock input high time		9			+ 10		ns
t <sub>CLA</sub>	Clock input low time		9			+ 10		ns
t <sub>COA</sub>	Clock to output delay			21		+ 10	- 2	ns
t <sub>ARDA</sub>	CPLD array delay	Any macrocell		11	+ 2			ns
t <sub>MINA</sub>	Minimum clock period	1/f <sub>CNTA</sub>	16					ns

**Table 129. CPLD macrocell asynchronous clock mode timing (3 V devices)**

Symbol	Parameter	Conditions	Min.	Max.	PT aloc	Turbo off	Slew rate	Unit
f <sub>MAXA</sub>	Maximum frequency external feedback	1/(t <sub>SA</sub> +t <sub>COA</sub> )		21.7				MHz
	Maximum frequency internal feedback (f <sub>CNTA</sub> )	1/(t <sub>SA</sub> +t <sub>COA</sub> -10)		27.8				MHz
	Maximum frequency pipelined data	1/(t <sub>CHA</sub> +t <sub>CLA</sub> )		33.3				MHz
t <sub>SA</sub>	Input setup time		10		+ 4	+ 20		ns
t <sub>HA</sub>	Input hold time		12					ns
t <sub>CHA</sub>	Clock input high time		17			+ 20		ns
t <sub>CLA</sub>	Clock input low time		13			+ 20		ns
t <sub>COA</sub>	Clock to output delay			36		+ 20	- 6	ns
t <sub>ARD</sub>	CPLD array delay	Any macrocell		25	+ 4			ns
t <sub>MINA</sub>	Minimum clock period	1/f <sub>CNTA</sub>	36					ns



Figure 76. Input macrocell timing (product term clock)

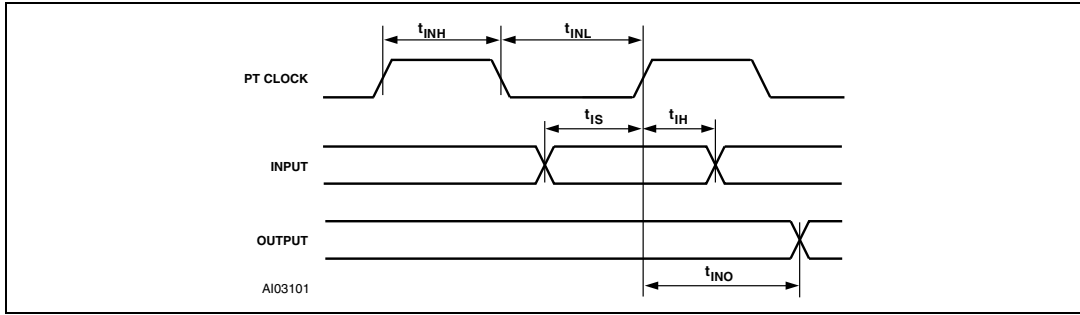

Table 130. Input macrocell timing (5 V devices)

Symbol	Parameter	Conditions	Min.	Max.	PT aloc	Turbo Off	Unit
$t_{IS}$	Input setup time	(Note 1)	0				ns
$t_{IH}$	Input hold time	(Note 1)	15			+ 10	ns
$t_{INH}$	NIB input high time	(Note 1)	9				ns
$t_{INL}$	NIB input low time	(Note 1)	9				ns
$t_{INO}$	NIB input to combinatorial delay	(Note 1)		34	+ 2	+ 10	ns

1. Inputs from Port A, B, and C relative to register/latch clock from the PLD. ALE/AS latch timings refer to  $t_{AVLX}$  and  $t_{LXAX}$ .

Table 131. Input macrocell timing (3 V devices)

Symbol	Parameter	Conditions	Min.	Max.	PT aloc	Turbo Off	Unit
$t_{IS}$	Input setup time	(Note 1)	0				ns
$t_{IH}$	Input hold time	(Note 1)	25			+ 20	ns
$t_{INH}$	NIB input high time	(Note 1)	12				ns
$t_{INL}$	NIB input low time	(Note 1)	12				ns
$t_{INO}$	NIB input to combinatorial delay	(Note 1)		46	+ 4	+ 20	ns

1. Inputs from Port A, B, and C relative to register/latch clock from the PLD. ALE latch timings refer to  $t_{AVLX}$  and  $t_{LXAX}$ .

**Table 132. Program, Write and Erase times (5 V devices)**

Symbol	Parameter	Min.	Typ.	Max.	Unit
	Flash Program		8.5		s
	Flash Bulk Erase <sup>(1)</sup> (pre-programmed)		3	30	s
	Flash Bulk Erase (not pre-programmed)		5		s
t <sub>WHQV3</sub>	Sector Erase (pre-programmed)		1	30	s
t <sub>WHQV2</sub>	Sector Erase (not pre-programmed)		2.2		s
t <sub>WHQV1</sub>	Byte Program		14	150	μs
	Program / Erase Cycles (per Sector)	100,000			cycles
t <sub>WHWLO</sub>	Sector Erase Time-Out		100		μs
t <sub>Q7VQV</sub>	DQ7 Valid to Output (DQ7-DQ0) Valid (Data Polling) <sup>(2)</sup>			30	ns

1. Programmed to all zero before erase.
2. The polling status, DQ7, is valid t<sub>Q7VQV</sub> time units before the data byte, DQ0-DQ7, is valid for reading.

**Table 133. Program, Write and Erase times (3 V devices)**

Symbol	Parameter	Min.	Typ.	Max.	Unit
	Flash Program		8.5		s
	Flash Bulk Erase <sup>(1)</sup> (pre-programmed)		3	30	s
	Flash Bulk Erase (not pre-programmed)		5		s
t <sub>WHQV3</sub>	Sector Erase (pre-programmed)		1	30	s
t <sub>WHQV2</sub>	Sector Erase (not pre-programmed)		2.2		s
t <sub>WHQV1</sub>	Byte Program		14	150	μs
	Program / Erase Cycles (per Sector)	100,000			cycles
t <sub>WHWLO</sub>	Sector Erase Time-Out		100		μs
t <sub>Q7VQV</sub>	DQ7 Valid to Output (DQ7-DQ0) Valid (Data Polling) <sup>(2)</sup>			30	ns

1. Programmed to all zero before erase.
2. The polling status, DQ7, is valid t<sub>Q7VQV</sub> time units before the data byte, DQ0-DQ7, is valid for reading.

Figure 77. Peripheral I/O Read timing

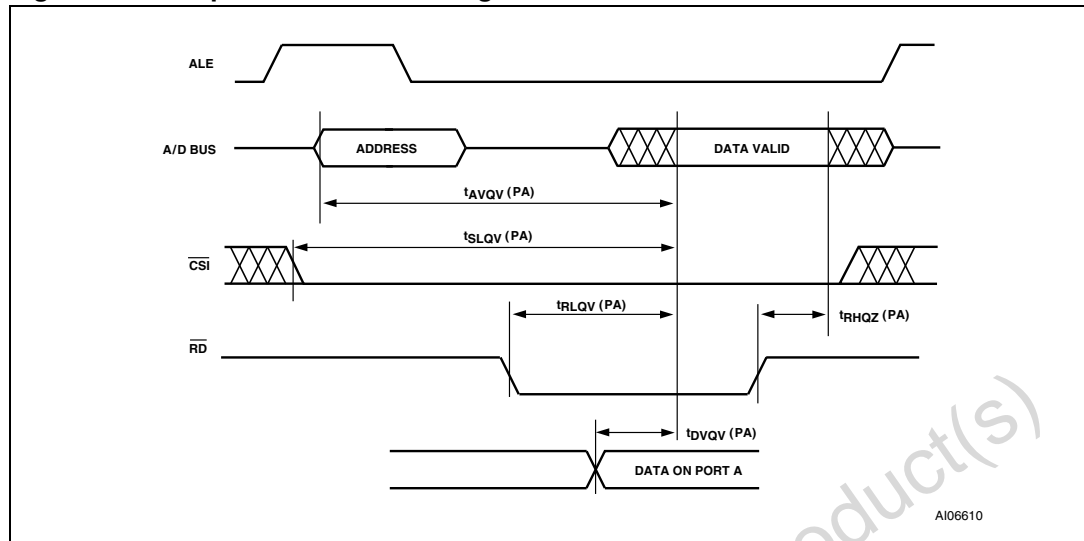

Table 134. Port A peripheral data mode Read timing (5 V devices)

Symbol	Parameter	Conditions	Min.	Max.	Turbo off	Unit
$t_{AVQV-PA}$	Address valid to data valid	(Note 1)		37	+ 10	ns
$t_{SLQV-PA}$	$\overline{CS}$ valid to data valid			27	+ 10	ns
$t_{RLQV-PA}$	$\overline{RD}$ to data valid	(Note 2)		32		ns
$t_{DVQV-PA}$	Data in to data out valid			22		ns
$t_{RHQZ-PA}$	$\overline{RD}$ to data high-Z			23		ns

1. Any input used to select Port A Data Peripheral mode.
2. Data is already stable on Port A.

Table 135. Port A peripheral data mode Read timing (3 V devices)

Symbol	Parameter	Conditions	Min.	Max.	Turbo off	Unit
$t_{AVQV-PA}$	Address valid to data valid	(Note 1)		50	+ 20	ns
$t_{SLQV-PA}$	$\overline{CS}$ valid to data valid			37	+ 20	ns
$t_{RLQV-PA}$	$\overline{RD}$ to data valid	(Note 2)		45		ns
$t_{DVQV-PA}$	Data in to data out valid			38		ns
$t_{RHQZ-PA}$	$\overline{RD}$ to data high-Z			36		ns

1. Any input used to select Port A Data Peripheral mode.
2. Data is already stable on Port A.

Figure 78. Peripheral I/O Write timing

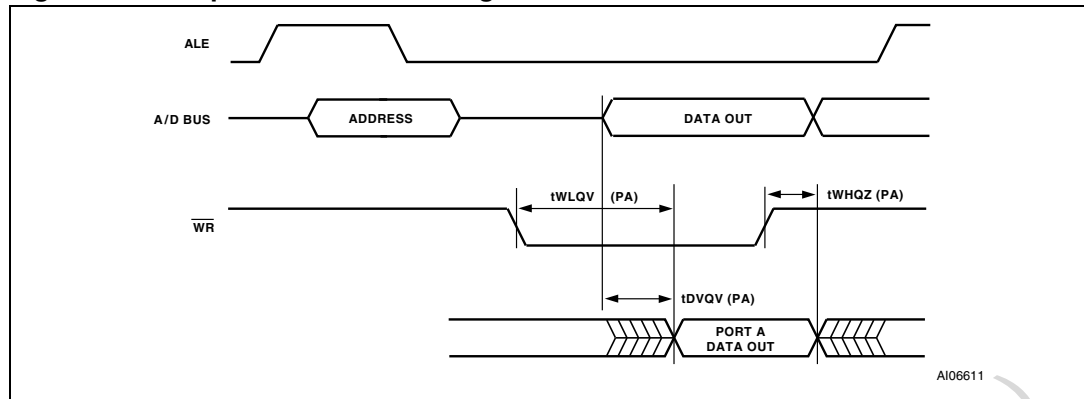

Table 136. Port A peripheral data mode Write timing (5 V devices)

Symbol	Parameter	Conditions	Min.	Max.	Unit
$t_{WLQV-PA}$	$\overline{WR}$ to Data Propagation Delay			25	ns
$t_{DVQV-PA}$	Data to Port A Data Propagation Delay	(Note 1)		22	ns
$t_{WHQZ-PA}$	$\overline{WR}$ Invalid to Port A Tri-state			20	ns

1. Data stable on Port 0 pins to data on Port A.

Table 137. Port A peripheral data mode Write timing (3 V devices)

Symbol	Parameter	Conditions	Min.	Max.	Unit
$t_{WLQV-PA}$	$\overline{WR}$ to data propagation delay			42	ns
$t_{DVQV-PA}$	Data to Port A data propagation delay	(Note 1)		38	ns
$t_{WHQZ-PA}$	$\overline{WR}$ invalid to Port A tri-state			33	ns

1. Data stable on Port 0 pins to data on Port A.

Figure 79. Reset ( $\overline{RESET}$ ) timing

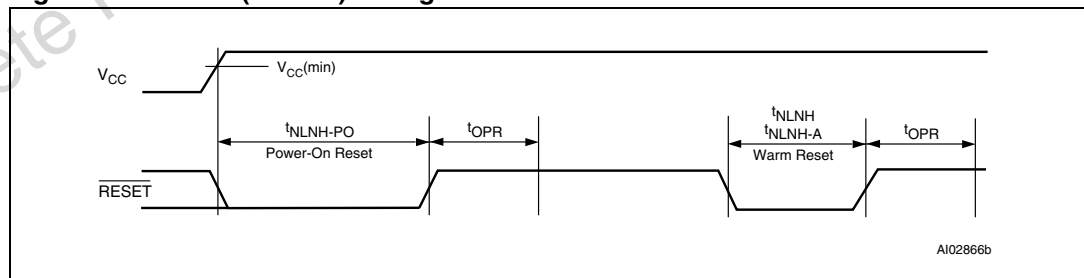

**Table 138. Reset ( $\overline{\text{RESET}}$ ) timing (5 V devices)**

Symbol	Parameter	Conditions	Min.	Max.	Unit
$t_{\text{NLNH}}$	$\overline{\text{RESET}}$ active low time <sup>(1)</sup>		150		ns
$t_{\text{NLNH-PO}}$	Power-on reset active low time		1		ms
$t_{\text{NLNH-A}}$	Warm $\overline{\text{RESET}}$ <sup>(2)</sup>		25		$\mu\text{s}$
$t_{\text{OPR}}$	$\overline{\text{RESET}}$ high to operational device			120	ns

1. Reset ( $\overline{\text{RESET}}$ ) does not reset Flash memory Program or Erase cycles.
2. Warm  $\overline{\text{RESET}}$  aborts Flash memory Program or Erase cycles, and puts the device in READ mode.

**Table 139. Reset ( $\overline{\text{RESET}}$ ) timing (3 V devices)**

Symbol	Parameter	Conditions	Min.	Max.	Unit
$t_{\text{NLNH}}$	$\overline{\text{RESET}}$ active low time <sup>(1)</sup>		300		ns
$t_{\text{NLNH-PO}}$	Power-on reset active low time		1		ms
$t_{\text{NLNH-A}}$	Warm $\overline{\text{RESET}}$ <sup>(2)</sup>		25		$\mu\text{s}$
$t_{\text{OPR}}$	$\overline{\text{RESET}}$ high to operational device			300	ns

1. Reset ( $\overline{\text{RESET}}$ ) does not reset Flash memory Program or Erase cycles.
2. Warm  $\overline{\text{RESET}}$  aborts Flash memory Program or Erase cycles, and puts the device in READ mode.

**Figure 80. ISC timing**

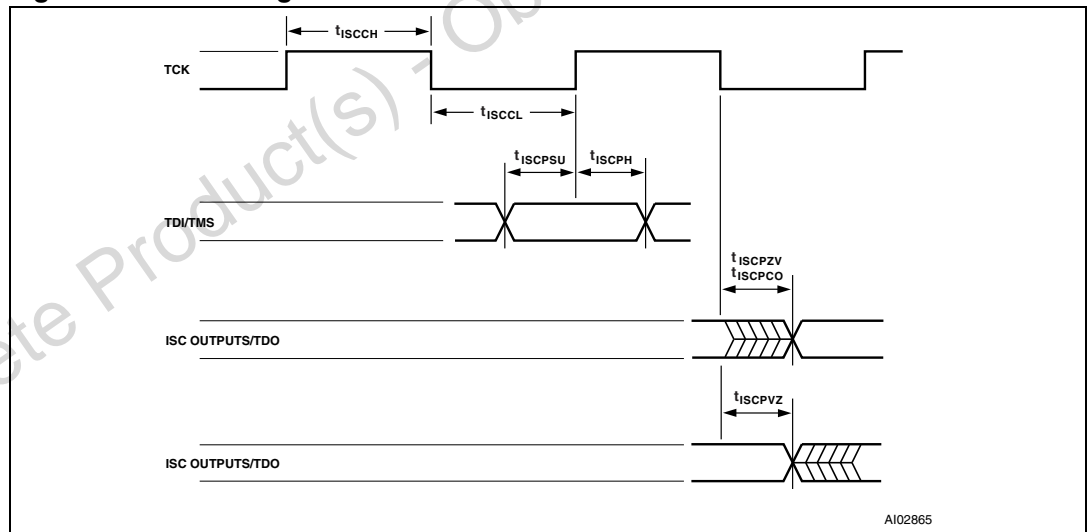

**Table 140. ISC timing (5 V devices)**

Symbol	Parameter	Conditions	Min.	Max.	Unit
t <sub>ISCCF</sub>	Clock (TCK, PC1) frequency (except for PLD)	(Note 1)		20	MHz
t <sub>ISCCH</sub>	Clock (TCK, PC1) high time (except for PLD)	(Note 1)	23		ns
t <sub>ISCCL</sub>	Clock (TCK, PC1) low time (except for PLD)	(Note 1)	23		ns
t <sub>ISCCFP</sub>	Clock (TCK, PC1) frequency (PLD only)	(Note 2)		2	MHz
t <sub>ISCCHP</sub>	Clock (TCK, PC1) high time (PLD only)	(Note 2)	240		ns
t <sub>ISCCLP</sub>	Clock (TCK, PC1) low time (PLD only)	(Note 2)	240		ns
t <sub>ISCP<sub>SU</sub></sub>	ISC port set-up time		7		ns
t <sub>ISCP<sub>H</sub></sub>	ISC port hold-up time		5		ns
t <sub>ISCP<sub>CO</sub></sub>	ISC port clock to output			21	ns
t <sub>ISCP<sub>ZV</sub></sub>	ISC port high-impedance to valid output			21	ns
t <sub>ISCP<sub>VZ</sub></sub>	ISC port valid output to high-impedance			21	ns

1. For non-PLD Programming, Erase or in ISC By-pass mode.
2. For Program or Erase PLD only.

**Table 141. ISC timing (3 V devices)**

Symbol	Parameter	Conditions	Min.	Max.	Unit
t <sub>ISCCF</sub>	Clock (TCK, PC1) frequency (except for PLD)	(Note 1)		12	MHz
t <sub>ISCCH</sub>	Clock (TCK, PC1) high time (except for PLD)	(Note 1)	40		ns
t <sub>ISCCL</sub>	Clock (TCK, PC1) low time (except for PLD)	(Note 1)	40		ns
t <sub>ISCCFP</sub>	Clock (TCK, PC1) frequency (PLD only)	(Note 2)		2	MHz
t <sub>ISCCHP</sub>	Clock (TCK, PC1) high time (PLD only)	(Note 2)	240		ns
t <sub>ISCCLP</sub>	Clock (TCK, PC1) low time (PLD only)	(Note 2)	240		ns
t <sub>ISCP<sub>SU</sub></sub>	ISC port set-up time		12		ns
t <sub>ISCP<sub>H</sub></sub>	ISC port hold-up time		5		ns
t <sub>ISCP<sub>CO</sub></sub>	ISC port clock to output			30	ns
t <sub>ISCP<sub>ZV</sub></sub>	ISC port high-impedance to valid output			30	ns
t <sub>ISCP<sub>VZ</sub></sub>	ISC port valid output to high-impedance			30	ns

1. For non-PLD Programming, Erase or in ISC By-pass mode.
2. For Program or Erase PLD only.

**Figure 81. MCU module AC measurement I/O waveform**

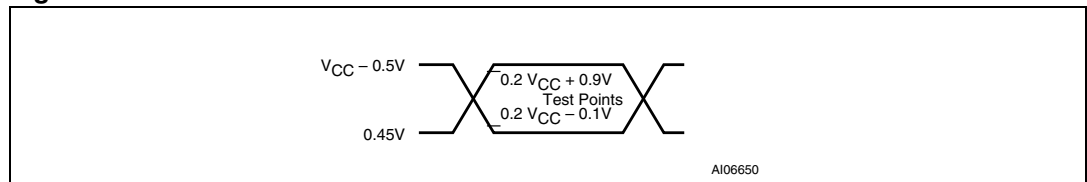

1. AC inputs during testing are driven at V<sub>CC</sub>-0.5 V for a logic '1,' and 0.45 V for a logic '0.'
2. Timing measurements are made at V<sub>IH</sub>(min) for a logic '1,' and V<sub>IL</sub>(max) for a logic '0'.

**Figure 82. PSD module AC float I/O waveform**

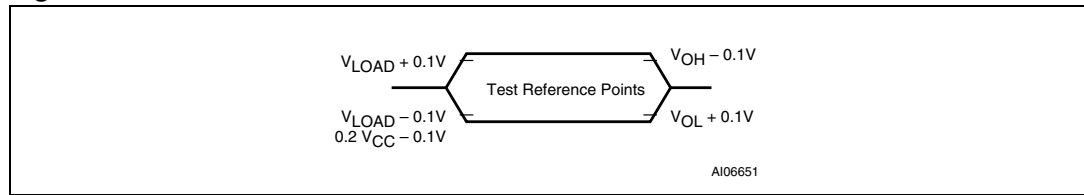

1. For timing purposes, a Port pin is considered to be no longer floating when a 100mV change from load voltage occurs, and begins to float when a 100mV change from the loaded  $V_{OH}$  or  $V_{OL}$  level occurs
2.  $I_{OL}$  and  $I_{OH} \geq 20\text{mA}$

**Figure 83. External clock cycle**

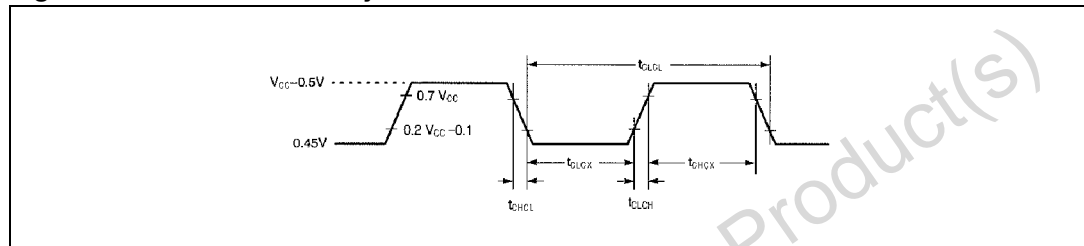

**Figure 84. Recommended oscillator circuits**

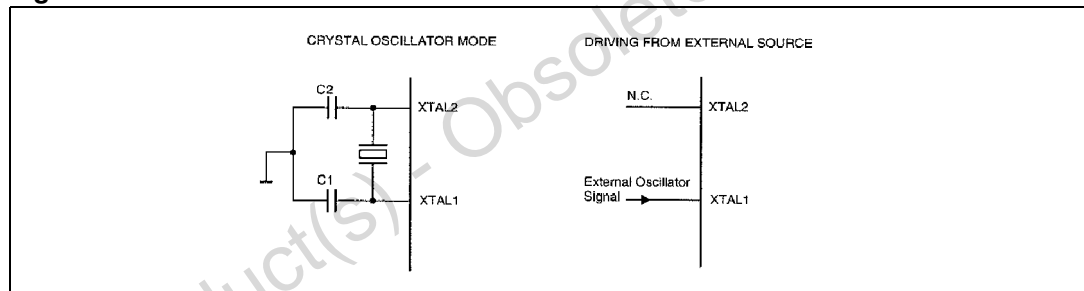

1.  $C1, C2 = 30 \text{ pF} \pm 10 \text{ pF}$  for crystals
2. For ceramic resonators, contact resonator manufacturer
3. Oscillation circuit is designed to be used either with a ceramic resonator or crystal oscillator. Since each crystal and ceramic resonator
4. have their own characteristics, the user should consult the crystal manufacturer for appropriate values of external components.

**Figure 85. PSD module AC measurement I/O waveform**

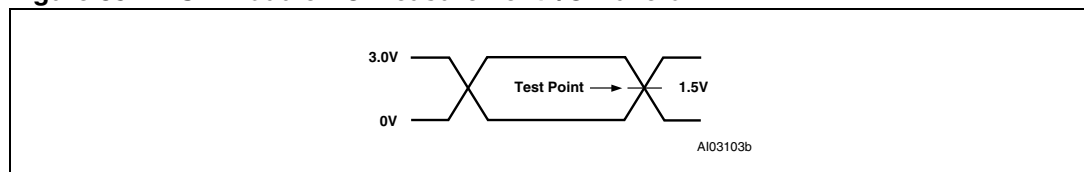

Figure 86. PSD module AC measurement load circuit

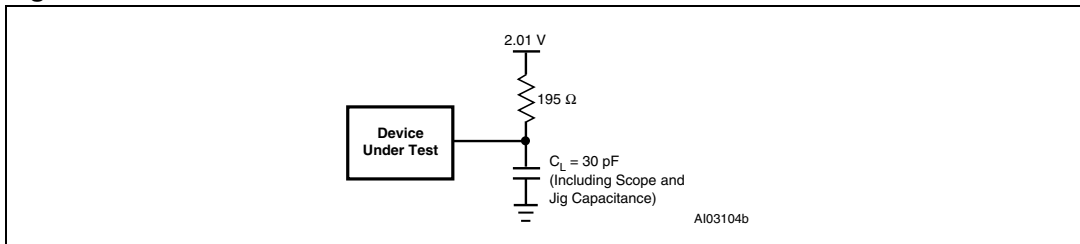

Table 142. Capacitance

Symbol	Parameter	Test conditions (1)	Typ.(2)	Max.	Unit
$C_{IN}$	Input capacitance (for input pins)	$V_{IN} = 0\text{ V}$	4	6	pF
$C_{OUT}$	Output capacitance (for input/output pins)	$V_{OUT} = 0\text{ V}$	8	12	pF

1. Sampled only, not 100% tested.
2. Typical values are for  $T_A = 25^\circ\text{C}$  and nominal supply voltages.



### 32 Package mechanical information

Figure 87. LQFP52 – 52-lead plastic thin, quad, flat package outline

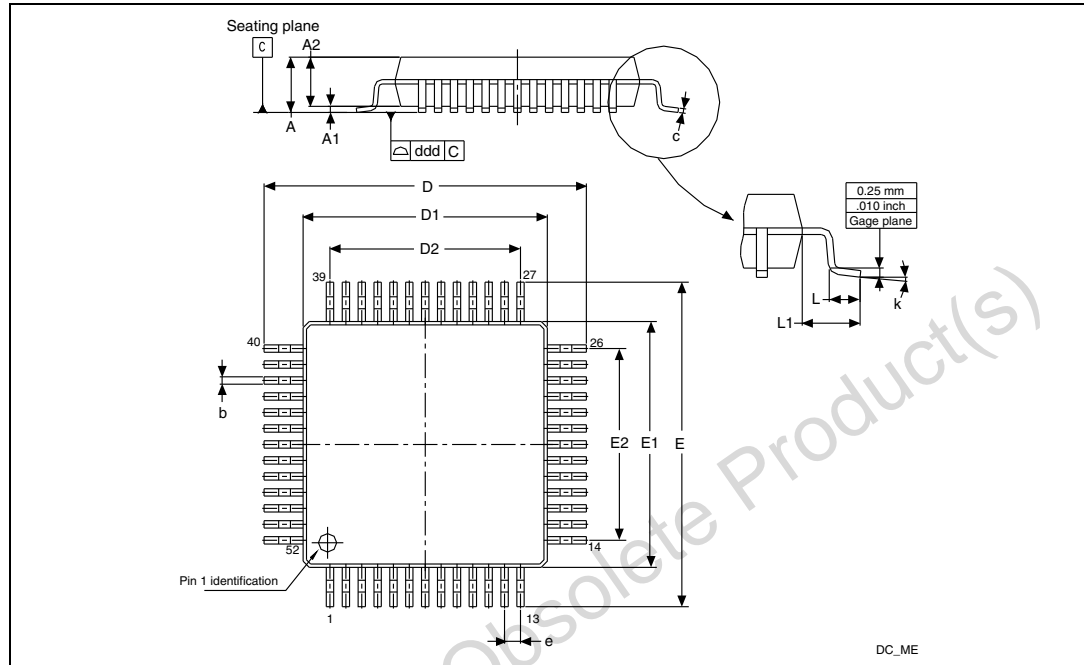

1. Drawing is not to scale.

Table 143. LQFP52 – 52-lead plastic thin, quad, flat package mechanical data

Symbol	millimeters			inches <sup>(1)</sup>		
	Typ	Min	Max	Typ	Min	Max
A			1.60			0.063
A1		0.05	0.15		0.002	0.0059
A2		1.35	1.45		0.0531	0.0571
b		0.22	0.38		0.0087	0.015
C		0.09	0.2		0.0035	0.0079
D	12			0.4724		
D1	10			0.3937		
D2	7.8			0.3071		
E	12			0.4724		
E1	10			0.3937		
E2	7.8			0.3071		
e	0.65			0.0256		
L		0.45	0.75		0.0177	0.0295
L1	1			0.0394		
k		0°	7°		0°	7°
ddd		0.100			0.0039	

1. Values in inches are converted from mm and rounded to 4 decimal digits.

Figure 88. LQFP80 – 80-lead plastic thin, quad, flat package outline

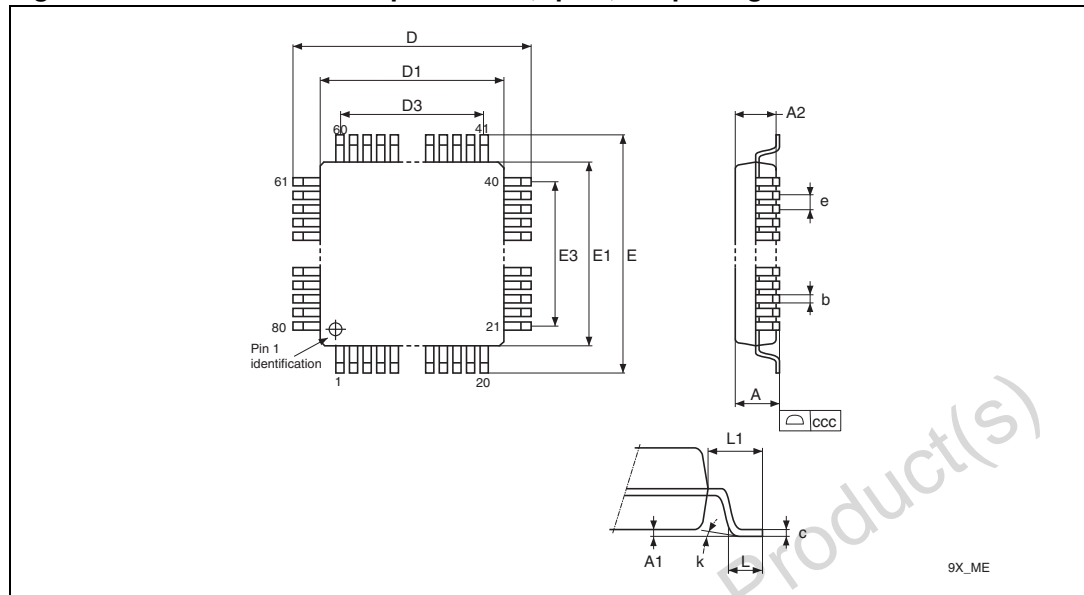

1. Drawing is not to scale.

Table 144. LQFP80 – 80-lead plastic thin, quad, flat package mechanical data

Symbol	millimeters			inches <sup>(1)</sup>		
	Typ	Min	Max	Typ	Min	Max
A			1.600			0.0630
A1		0.050	0.150		0.0020	0.0059
A2	1.400	1.350	1.450	0.0551	0.0531	0.0571
b	0.220	0.170	0.270	0.0087	0.0067	0.0106
C		0.090	0.200		0.0035	0.0079
D	14.000			0.5512		
D1	12.000			0.4724		
D3	9.500			0.3740		
E	14.000			0.5512		
E1	12.000			0.4724		
E3	9.500			0.3740		
e	0.500			0.0197		
L	0.600	0.450	0.750	0.0236	0.0177	0.0295
L1	1.000			0.0394		
k		0°	7°		0°	7°
ccc		0.080			0.0031	

1. Values in inches are converted from mm and rounded to 4 decimal digits.

### 33 Part numbering

**Table 145. Ordering information scheme**

Example:	UPSD	3	2	1	4	B	V	-	24	U	6	T
<b>Device type</b> UPSD = Microcontroller PSD												
<b>Family</b> 3 = 8032 core												
<b>PLD size</b> 2 = 16 Macrocells												
<b>SRAM Size</b> 1 = 2 Kbytes												
<b>Main Flash memory size</b> 2 = 64 Kbytes 3 = 128 Kbytes 4 = 256 Kbytes												
<b>IP mix</b> A = USB, I <sup>2</sup> C, PWM, DDC, ADC, (2) UARTs, Supervisor (Reset Out, Reset In, LVD, WD) B = I <sup>2</sup> C, PWM, DDC, ADC, (2) UARTs Supervisor (Reset Out, Reset In, LVD, WD)												
<b>Operating voltage</b> blank = V <sub>CC</sub> = 4.5 to 5.5 V V = V <sub>CC</sub> = 3.0 to 3.6 V												
<b>Speed</b> -24 = 24 MHz -40 = 40 MHz												
<b>Package</b> T = 52-pin LQFP U = 80-pin LQFP												
<b>Temperature range</b> 1 = 0 to 70°C 6 = -40 to 85°C												
<b>Shipping options</b> F = ECOPACK <sup>®</sup> Package, Tape & Reel Packing												

For other options, or for more information on any aspect of this device, please contact the ST Sales Office nearest you.

## 34 Revision history

**Table 146. Document revision history**

Date	Revision	Changes
18-Dec-2002	1.0	First Issue
04-Mar-03	1.1	Updates: port information (Table 30); interface information (Figure 30, Table 44); remove programming guide; PSD module information (Table 82); PLD information (Figure 55); electrical characteristics (Table 114, 115, 131, 132)
02-Sep-03	1.2	Update references for Product Catalog
03-Feb-04	2.0	Reformatted; correct package dimensions (Table 145)
02-July-04	3.0	Reformatted; add EMC characteristics information (Table 106, 107, 108)
04-Nov-04	4.0	Updates per requested data brief changes (Figure 3, 4; Table 1, 2, 113)
03-Dec-04	5.0	Add USB feature to document (Figure 2, 3, 4, 15, 16, 18, 20, 40, 41, 42, 43, 44, 45; Table 1, 2, 15, 16, 18, 19, 21, 23, 24, 25, 60, 61, 62, 63, 64, 65, 66, 67, 68, 69, 70, 71, 72, 73, 74, 75, 76, 77, 78, 79, 146)
21-Jan-2009	6.0	Removed battery backup feature and related SRAM Standby mode information. Added Ecopack information and updated <a href="#">Section 32: Package mechanical information on page 177</a> .

**Please Read Carefully:**

Information in this document is provided solely in connection with ST products. STMicroelectronics NV and its subsidiaries ("ST") reserve the right to make changes, corrections, modifications or improvements, to this document, and the products and services described herein at any time, without notice.

All ST products are sold pursuant to ST's terms and conditions of sale.

Purchasers are solely responsible for the choice, selection and use of the ST products and services described herein, and ST assumes no liability whatsoever relating to the choice, selection or use of the ST products and services described herein.

No license, express or implied, by estoppel or otherwise, to any intellectual property rights is granted under this document. If any part of this document refers to any third party products or services it shall not be deemed a license grant by ST for the use of such third party products or services, or any intellectual property contained therein or considered as a warranty covering the use in any manner whatsoever of such third party products or services or any intellectual property contained therein.

**UNLESS OTHERWISE SET FORTH IN ST'S TERMS AND CONDITIONS OF SALE ST DISCLAIMS ANY EXPRESS OR IMPLIED WARRANTY WITH RESPECT TO THE USE AND/OR SALE OF ST PRODUCTS INCLUDING WITHOUT LIMITATION IMPLIED WARRANTIES OF MERCHANTABILITY, FITNESS FOR A PARTICULAR PURPOSE (AND THEIR EQUIVALENTS UNDER THE LAWS OF ANY JURISDICTION), OR INFRINGEMENT OF ANY PATENT, COPYRIGHT OR OTHER INTELLECTUAL PROPERTY RIGHT.**

**UNLESS EXPRESSLY APPROVED IN WRITING BY AN AUTHORIZED ST REPRESENTATIVE, ST PRODUCTS ARE NOT RECOMMENDED, AUTHORIZED OR WARRANTED FOR USE IN MILITARY, AIR CRAFT, SPACE, LIFE SAVING, OR LIFE SUSTAINING APPLICATIONS, NOR IN PRODUCTS OR SYSTEMS WHERE FAILURE OR MALFUNCTION MAY RESULT IN PERSONAL INJURY, DEATH, OR SEVERE PROPERTY OR ENVIRONMENTAL DAMAGE. ST PRODUCTS WHICH ARE NOT SPECIFIED AS "AUTOMOTIVE GRADE" MAY ONLY BE USED IN AUTOMOTIVE APPLICATIONS AT USER'S OWN RISK.**

Resale of ST products with provisions different from the statements and/or technical features set forth in this document shall immediately void any warranty granted by ST for the ST product or service described herein and shall not create or extend in any manner whatsoever, any liability of ST.

ST and the ST logo are trademarks or registered trademarks of ST in various countries.

Information in this document supersedes and replaces all information previously supplied.

The ST logo is a registered trademark of STMicroelectronics. All other names are the property of their respective owners.

© 2009 STMicroelectronics - All rights reserved

STMicroelectronics group of companies

Australia - Belgium - Brazil - Canada - China - Czech Republic - Finland - France - Germany - Hong Kong - India - Israel - Italy - Japan - Malaysia - Malta - Morocco - Singapore - Spain - Sweden - Switzerland - United Kingdom - United States of America

[www.st.com](http://www.st.com)

