

- **21:3 Data Channel Compression at up to 1.36 Gigabits per Second Throughput**
- **Suited for Point-to-Point Subsystem Communication With Very Low EMI**
- **21 Data Channels Plus Clock In Low-Voltage TTL and 3 Data Channels Plus Clock Out Low-Voltage Differential**
- **Operates From a Single 3.3-V Supply and 250 mW (Typ)**
- **5-V Tolerant Data Inputs**
- **LVDS95 has Rising Clock Edge Triggered Inputs**
- **Bus Pins Tolerate 6-kV HBM ESD**
- **Packaged in Thin Shrink Small-Outline Package With 20 Mil Terminal Pitch**
- **Consumes <1 mW When Disabled**
- **Wide Phase-Lock Input Frequency Range 31 MHz to 65 MHz**
- **No External Components Required for PLL**
- **Inputs Meet or Exceed the Requirements of ANSI EIA/TIA-644 Standard**
- **Industrial Temperature Qualified**
 $T_A = -40^{\circ}\text{C}$ to 85°C
- **Replacement for the National DS90CR215**

**DGG PACKAGE
(TOP VIEW)**

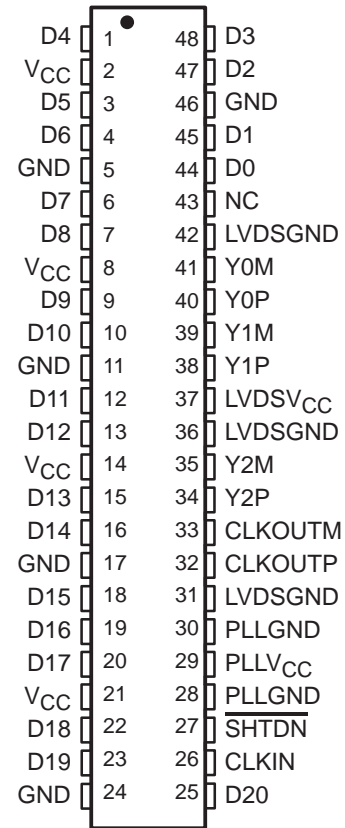

description

The SN65LVDS95 LVDS Serdes (serializer/deserializer) transmitter contains three 7-bit parallel-load serial-out shift registers, a 7× clock synthesizer, and four low-voltage differential signaling (LVDS) line drivers in a single integrated circuit. These functions allow 21 bits of single-ended LVTTTL data to be synchronously transmitted over 4 balanced-pair conductors for receipt by a compatible receiver, such as the SN65LVDS96.

When transmitting, data bits D0 through D20 are each loaded into registers of the SN65LVDS95 on the rising edge of the input clock signal (CLKIN). The frequency of CLKIN is multiplied seven times and then used to serially unload the data registers in 7-bit slices. The three serial streams and a phase-locked clock (CLKOUT) are then output to LVDS output drivers. The frequency of CLKOUT is the same as the input clock, CLKIN.

The SN65LVDS95 requires no external components and little or not control. The data bus appears the same at the input to the transmitter and output of the receiver with data transmission transparent to the user(s). The only user intervention is the possible use of the Shutdown/Clear (SHTDN) active-low input to inhibit the clock and shut off the LVDS output drivers for lower power consumption. A low level on this signal clears all internal registers to a low level.

The SN65LVDS95 is characterized for operation over ambient air temperatures of -40°C to 85°C .



Please be aware that an important notice concerning availability, standard warranty, and use in critical applications of Texas Instruments semiconductor products and disclaimers thereto appears at the end of this data sheet.

SN65LVDS95 LVDS SERDES TRANSMITTER

SLLS297D – MAY 1998 – REVISED JULY 1999

functional block diagram

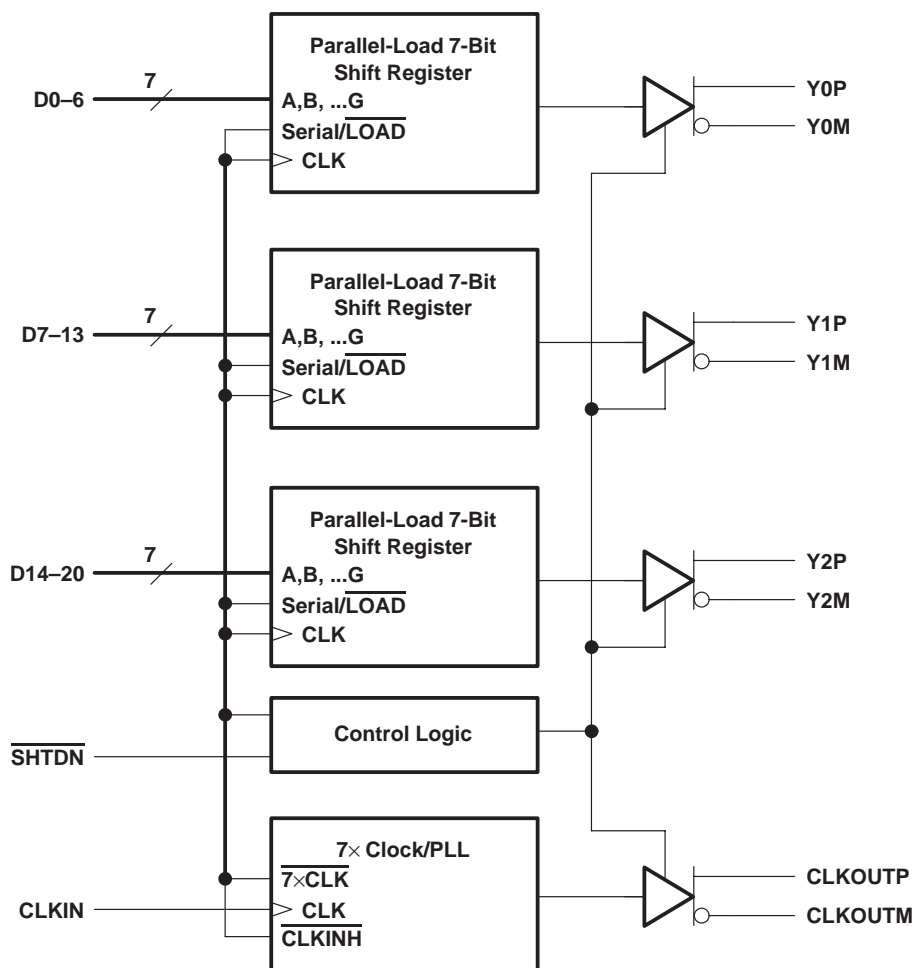

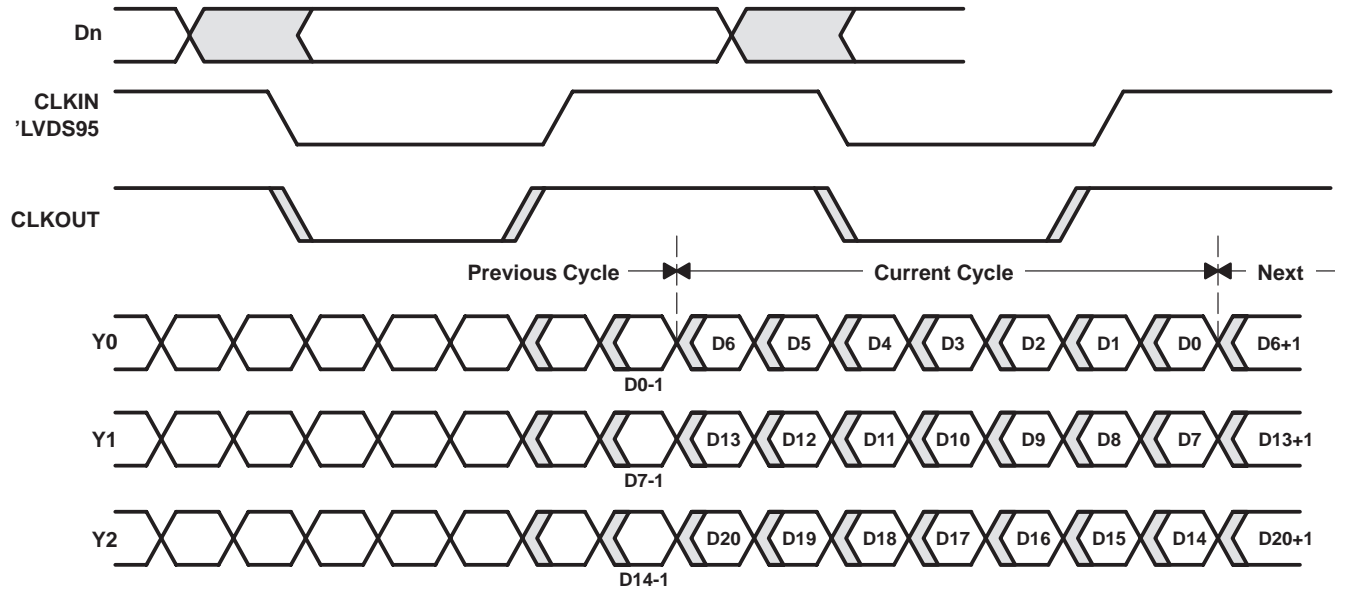
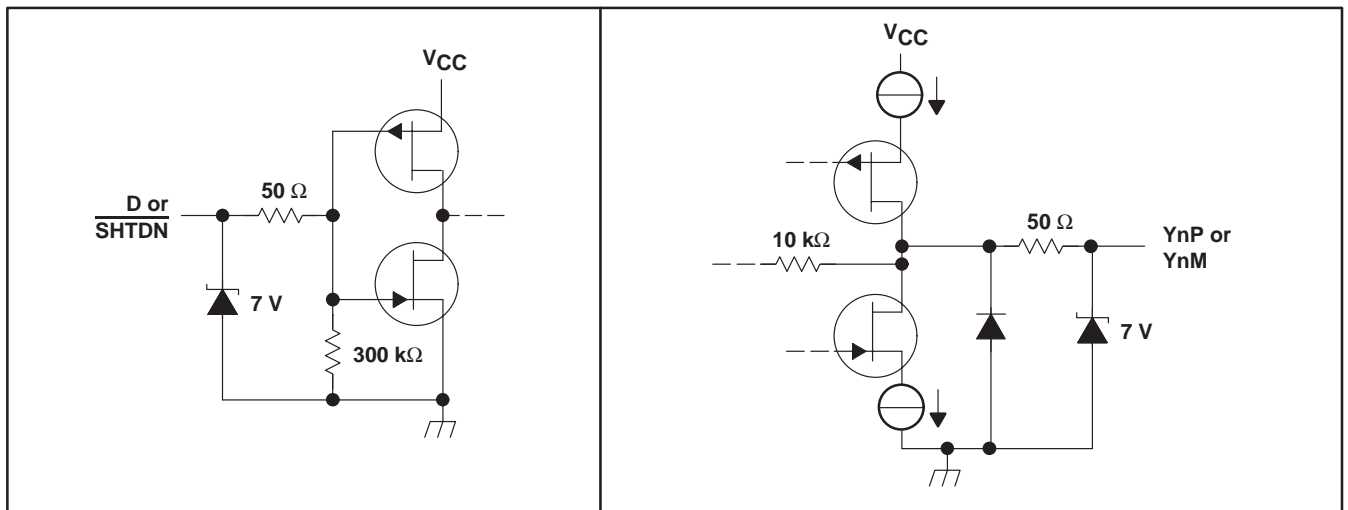

Figure 1. 'LVDS95 Load and Shift Sequences

equivalent input and output schematic diagrams



SN65LVDS95 LVDS SERDES TRANSMITTER

SLLS297D – MAY 1998 – REVISED JULY 1999

absolute maximum ratings over operating free-air temperature (unless otherwise noted)†

Supply voltage range, V_{CC} (see Note 1)	-0.5 V to 4 V
Voltage range at any output terminal, V_O	-0.5 V to $V_{CC} + 0.5$ V
Voltage range at any input terminal, V_I	-0.5 V to 5.5 V
Electrostatic discharge (see Note 2): Bus pins (Class 3A)	6 KV
Bus pins (Class 2B)	400 V
All pins (Class 3A)	6 KV
All pins (Class 2B)	200 V
Continuous total power dissipation	(see Dissipation Rating Table)
Operating free-air temperature range, T_A	-40°C to 85°C
Storage temperature range, T_{stg}	-65°C to 150°C
Lead temperature 1,6 mm (1/16 inch) from case for 10 seconds	260°C

† Stresses beyond those listed under “absolute maximum ratings” may cause permanent damage to the device. These are stress ratings only, and functional operation of the device at these or any other conditions beyond those indicated under “recommended operating conditions” is not implied. Exposure to absolute-maximum-rated conditions for extended periods may affect device reliability.

- NOTES: 1. All voltage values are with respect to the GND terminals.
2. This rating is measured using MIL-STD-883C Method, 3015.7.

DISSIPATION RATING TABLE

PACKAGE	$T_A \leq 25^\circ\text{C}$ POWER RATING	DERATING FACTOR‡ ABOVE $T_A = 25^\circ\text{C}$	$T_A = 70^\circ\text{C}$ POWER RATING	$T_A = 85^\circ\text{C}$ POWER RATING
DGG	1316 mW	13.1 mW/°C	724 mW	526 mW

‡ This is the inverse of the junction-to-ambient thermal resistance when board-mounted and with no air flow.

recommended operating conditions

	MIN	NOM	MAX	UNIT
Supply voltage, V_{CC}	3	3.3	3.6	V
High-level input voltage, V_{IH}	2			V
Low-level input voltage, V_{IL}			0.8	V
Differential load impedance, Z_L	90		132	Ω
Operating free-air temperature, T_A	-40		85	°C



electrical characteristics over recommended operating conditions (unless otherwise noted)

PARAMETER		TEST CONDITIONS	MIN	TYP†	MAX	UNIT
V_{IT}	Input voltage threshold			1.4		V
$ V_{OD} $	Differential steady-state output voltage magnitude	$R_L = 100 \Omega$, See Figure 3	247		454	mV
$\Delta V_{OD} $	Change in the steady-state differential output voltage magnitude between opposite binary states				50	
$V_{OC(SS)}$	Steady-state common-mode output voltage	See Figure 3	1.125		1.375	V
$V_{OC(PP)}$	Peak-to-peak common-mode output voltage			80	150	mV
I_{IH}	High-level input current	$V_{IH} = V_{CC}$			20	μA
I_{IL}	Low-level input current	$V_{IL} = 0 V$			± 10	μA
I_{OS}	Short-circuit output current	$V_{OY} = 0 V$			± 24	mA
		$V_{OD} = 0 V$			± 12	mA
I_{OZ}	High-impedance state output current	$V_O = 0 V$ to V_{CC}			± 10	μA
$I_{CC(AVG)}$	Quiescent current (average)	Disabled, all inputs at GND			280	μA
		Enabled, $R_L = 100 \Omega$ (4 places), Worstcase pattern (see Figure 4), $t_c = 15.38 ns$		85	110	mA
C_i	Input capacitance			3		pF

† All typical values are $V_{CC} = 3.3 V$, $T_A = 25^\circ C$.

timing requirements

		MIN	NOM	MAX	UNIT
t_c	Input clock period	15.4	t_c	32.4	ns
t_w	High-level input clock pulse width duration	$0.4t_c$		$0.6t_c$	ns
t_t	Input signal transition time			5	ns
	Data setup time, D0 through D27 before $CLKIN\uparrow$ ('95) (see Figure 2)	3			ns
	Data hold time, D0 through D27 after $CLKIN\uparrow$ ('95) (see Figure 2)	1.5			ns

SN65LVDS95 LVDS SERDES TRANSMITTER

SLLS297D – MAY 1998 – REVISED JULY 1999

switching characteristics over recommended operating conditions (unless otherwise noted)

PARAMETER	TEST CONDITIONS	MIN	TYP†	MAX	UNIT
t_0 Delay time, CLKOUT serial bit position 0	$t_C = 15.38 \text{ ns } (\pm 0.2\%),$ Input clock jitter < 50 ps‡, See Figure 5	-0.20	0	0.20	ns
t_1 Delay time, CLKOUT serial bit position 1		$1/7t_C - 0.20$		$1/7t_C + 0.20$	ns
t_2 Delay time, CLKOUT serial bit position 2		$2/7t_C - 0.20$		$2/7t_C + 0.20$	ns
t_3 Delay time, CLKOUT serial bit position 3		$3/7t_C - 0.20$		$3/7t_C + 0.20$	ns
t_4 Delay time, CLKOUT serial bit position 4		$4/7t_C - 0.20$		$4/7t_C + 0.20$	ns
t_5 Delay time, CLKOUT serial bit position 5		$5/7t_C - 0.20$		$5/7t_C + 0.20$	ns
t_6 Delay time, CLKOUT serial bit position 6		$6/7t_C - 0.20$		$6/7t_C + 0.20$	ns
$t_{sk(o)}$ Output skew, $t_n - n/7 t_C$		-0.20		0.20	ns
t_7 Delay time, CLKIN to CLKOUT	$t_C = 15.38 \text{ ns } (\pm 0.2\%),$ Input clock jitter < 50 ps‡, See Figure 5		4.2		ns
$\Delta t_{C(O)}$ Output clock cycle-to-cycle jitter§	$t_C = 15.38 \text{ ns } + 0.75 \sin(2\pi 500E3t)$ $\pm 0.05 \text{ ns, See Figure 6}$		± 80		ps
	$t_C = 15.38 \text{ ns } + 0.75 \sin(2\pi 2E6t)$ $\pm 0.05 \text{ ns, See Figure 6}$		± 300		ps
t_W High-level output clock pulse duration			$4/7 t_C$		ns
t_t Differential output voltage transition time (t_r or t_f)	See Figure 3	260	700	1500	ps
t_{en} Enable time, $\overline{\text{SHTDN}}$ to phase lock (Yn valid)	See Figure 7		1		ms
t_{dis} Disable time, $\overline{\text{SHTDNO}}$ to off-state (CLKOUT low)	See Figure 8		250		ns

† All typical values are $V_{CC} = 3.3 \text{ V}, T_A = 25^\circ\text{C}$.

‡ |Input clock jitter| is the magnitude of the change in the input clock period.

§ The output clock jitter is the change in the output clock period from one cycle to the next cycle observed over 15,000 cycles.

PARAMETER MEASUREMENT INFORMATION

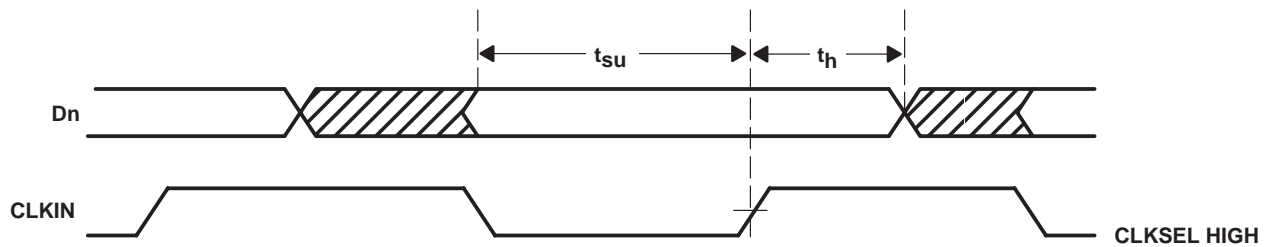

NOTE: All input timing is defined at 1.4 V on an input signal with a 10% to 90% rise or fall time of less than 5 ns.

Figure 2. Setup and Hold Time Definition

PARAMETER MEASUREMENT INFORMATION

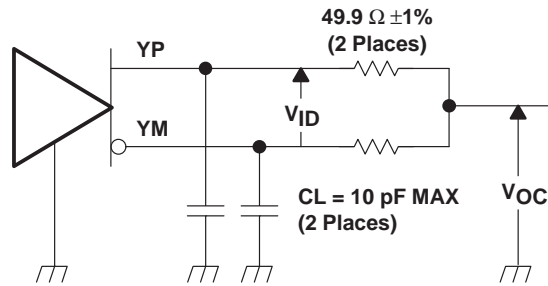

NOTE: The lumped instrumentation capacitance for any single ended voltage measurement is less than or equal to 10 pF.
When making measurements at YP or YM, the complementary output shall be similarly loaded.

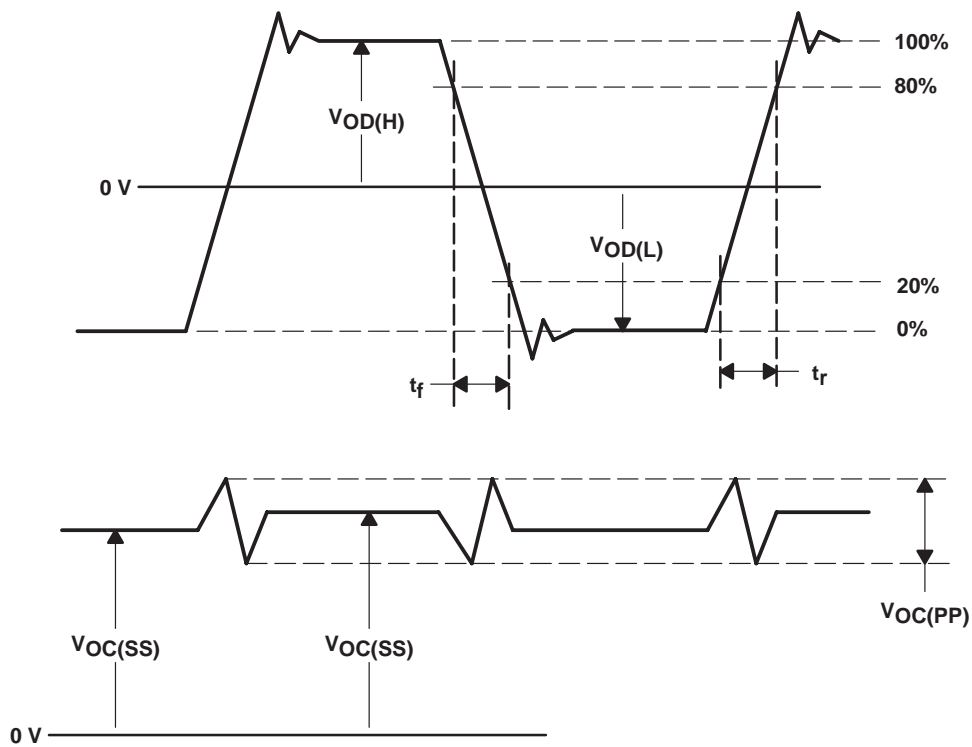

Figure 3. Test Load and Voltage Definitions for LVDS Outputs

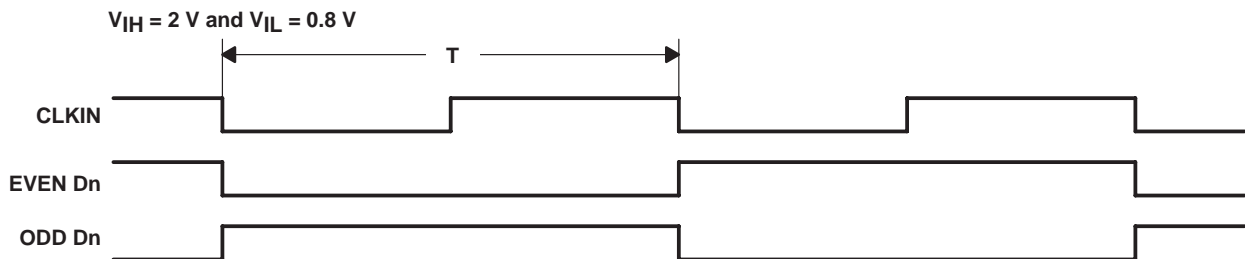

Figure 4. Worst-Case[‡] Power Test Pattern

[‡] The worst-case test pattern produces nearly the maximum switching frequency for all of the LV-TTL outputs.

SN65LVDS95 LVDS SERDES TRANSMITTER

SLLS297D – MAY 1998 – REVISED JULY 1999

PARAMETER MEASUREMENT INFORMATION

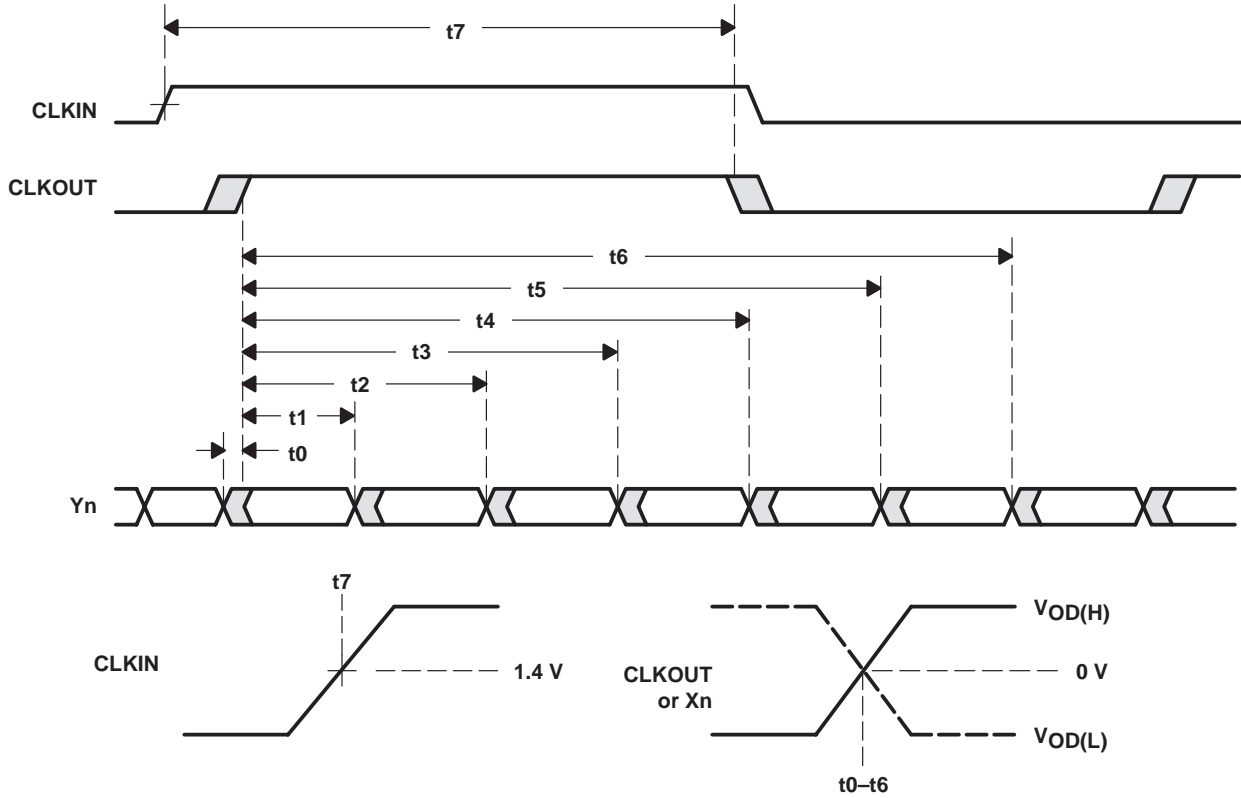

Figure 5. Timing Definitions

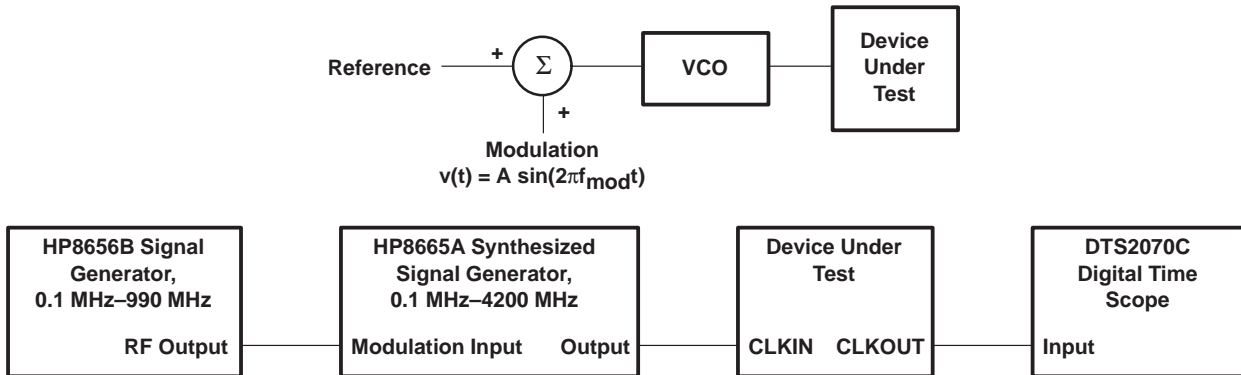

Figure 6. Clock Jitter Test Setup

PARAMETER MEASUREMENT INFORMATION

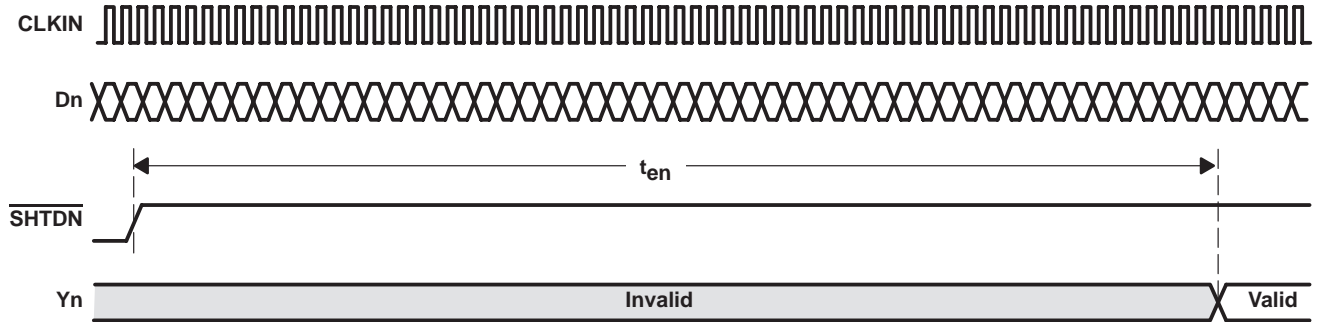

Figure 7. Enable Time Measurement Definition

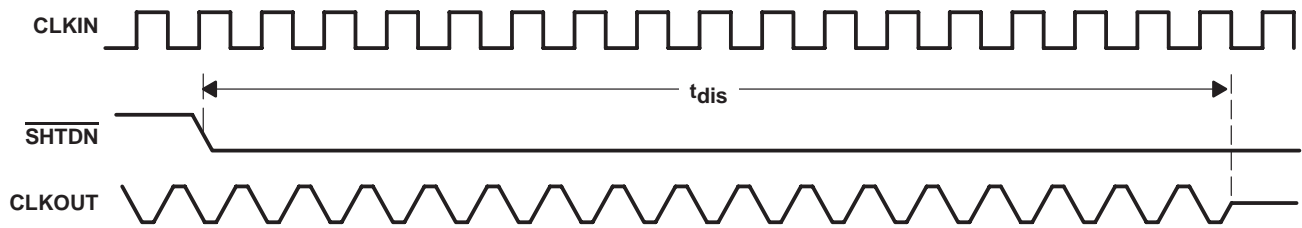

Figure 8. Disable Time Measurement Definition

TYPICAL CHARACTERISTICS

WORST-CASE SUPPLY CURRENT
vs
FREQUENCY

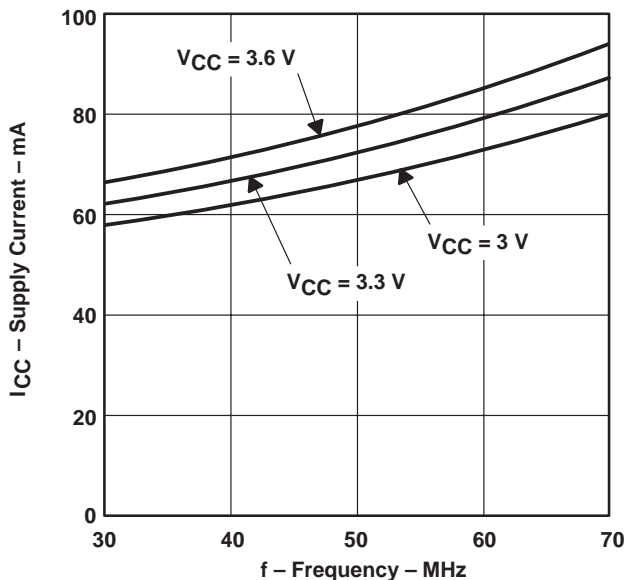

Figure 9

ZERO-TO-PEAK OUTPUT JITTER
vs
MODULATION FREQUENCY

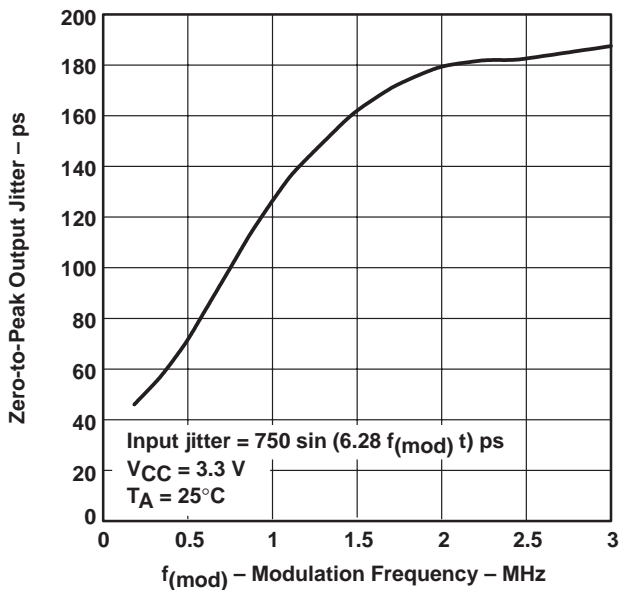

Figure 10

APPLICATION INFORMATION

16-Bit Bus Extension

In a 16-bit bus application (Figure 11), TTL data and clock coming from bus transceivers that interface the backplane bus arrive at the Tx parallel inputs of the LVDS serdes transmitter. The clock associated with the bus is also connected to the device. The on-chip PLL synchronizes this clock with the parallel data at the input. The data is then multiplexed into three different line drivers which perform the TTL to LVDS conversion. The clock is also converted to LVDS and presented to a separate driver. This synchronized LVDS data and clock at the receiver, which recovers the LVDS data and clock, performs a conversion back to TTL. Data is then demultiplexed into a parallel format. An on-chip PLL synchronizes the received clock with the parallel data, and then all are presented to the parallel output port of the receiver.

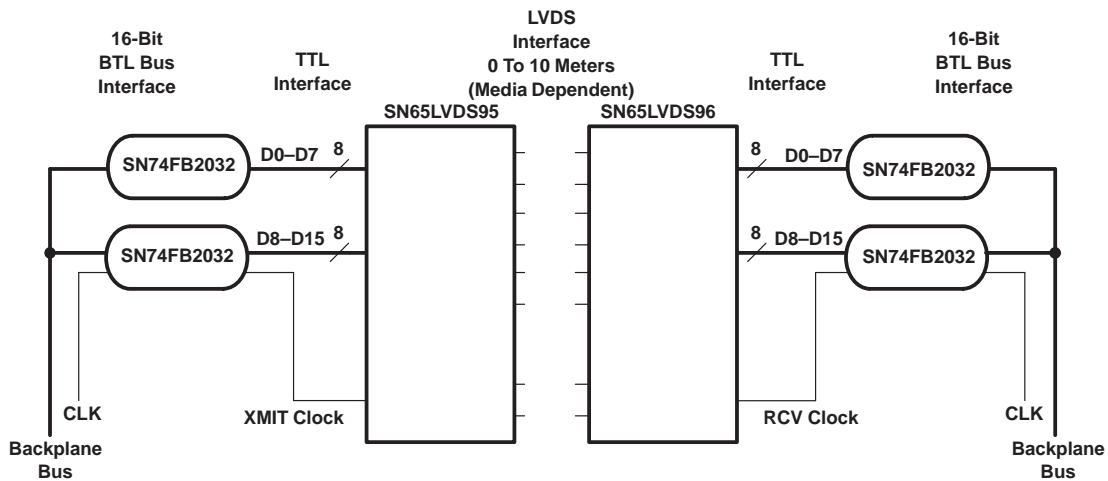

Figure 11. 16-Bit Bus Extension

16-Bit Bus Extension With Parity

In the previous application we did not have a checking bit that would provide assurance that the data crosses the link. If we add to the previous example a parity bit, we would have a diagram similar to the one in Figure 12. The device following the SN74FB2032 is a low cost parity generator. Each transmit-side transceiver/parity generator takes the LVTTTL data from the corresponding transceiver, performs a parity calculation over the byte, and then passes the bits with its calculated parity value on the parallel input of the LVDS serdes transmitter. Again, the on-chip PLL synchronizes this transmit clock with the eighteen parallel bits (16 data + 2 parity) at the input. The synchronized LVDS data/parity and clock arrive at the receiver.

The receiver performs the conversion from LVDS to LVTTTL and the transceiver/parity generator performs the parity calculations. These devices compare their corresponding input bytes with the value received on the parity bit. The transceiver/parity generator will assert its parity error output if a mismatch is detected.

SN65LVDS95 LVDS SERDES TRANSMITTER

SLLS297D – MAY 1998 – REVISED JULY 1999

APPLICATION INFORMATION

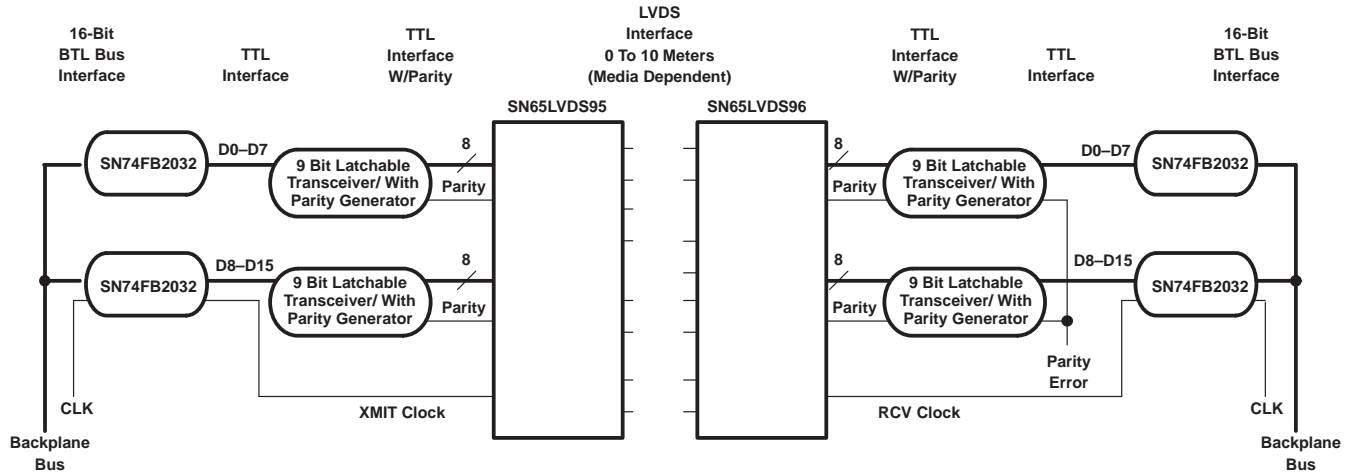

Figure 12. 16-Bit Bus Extension With Parity

Low Cost Virtual Backplane Transceiver

Figure 13 represents LVDS serdes in an application as a virtual backplane transceiver (VBT). The concept of a VBT can be achieved by implementing individual LVDS serdes chipsets in both directions of subsystem serialized links.

Depending on the application, the designer will face varying choices when implementing a VBT. In addition to the devices shown in Figure 13, functions such as parity and delay lines for control signals could be included. Using additional circuitry, half-duplex or full-duplex operation can be achieved by configuring the clock and control lines properly.

The designer may choose to implement an independent clock oscillator at each end of the link and then use a PLL to synchronize LVDS serdes's parallel I/O to the backplane bus. Resynchronizing FIFOs may also be required.

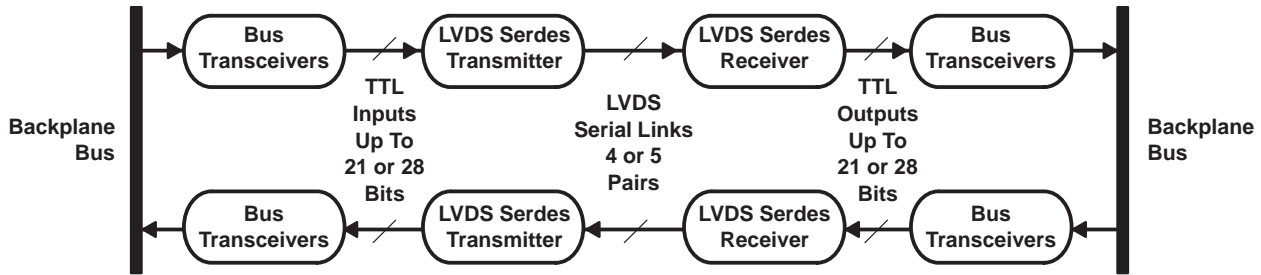

Figure 13. Virtual Backplane Transceiver

MECHANICAL DATA

DGG (R-PDSO-G**)

PLASTIC SMALL-OUTLINE PACKAGE

48 PIN SHOWN

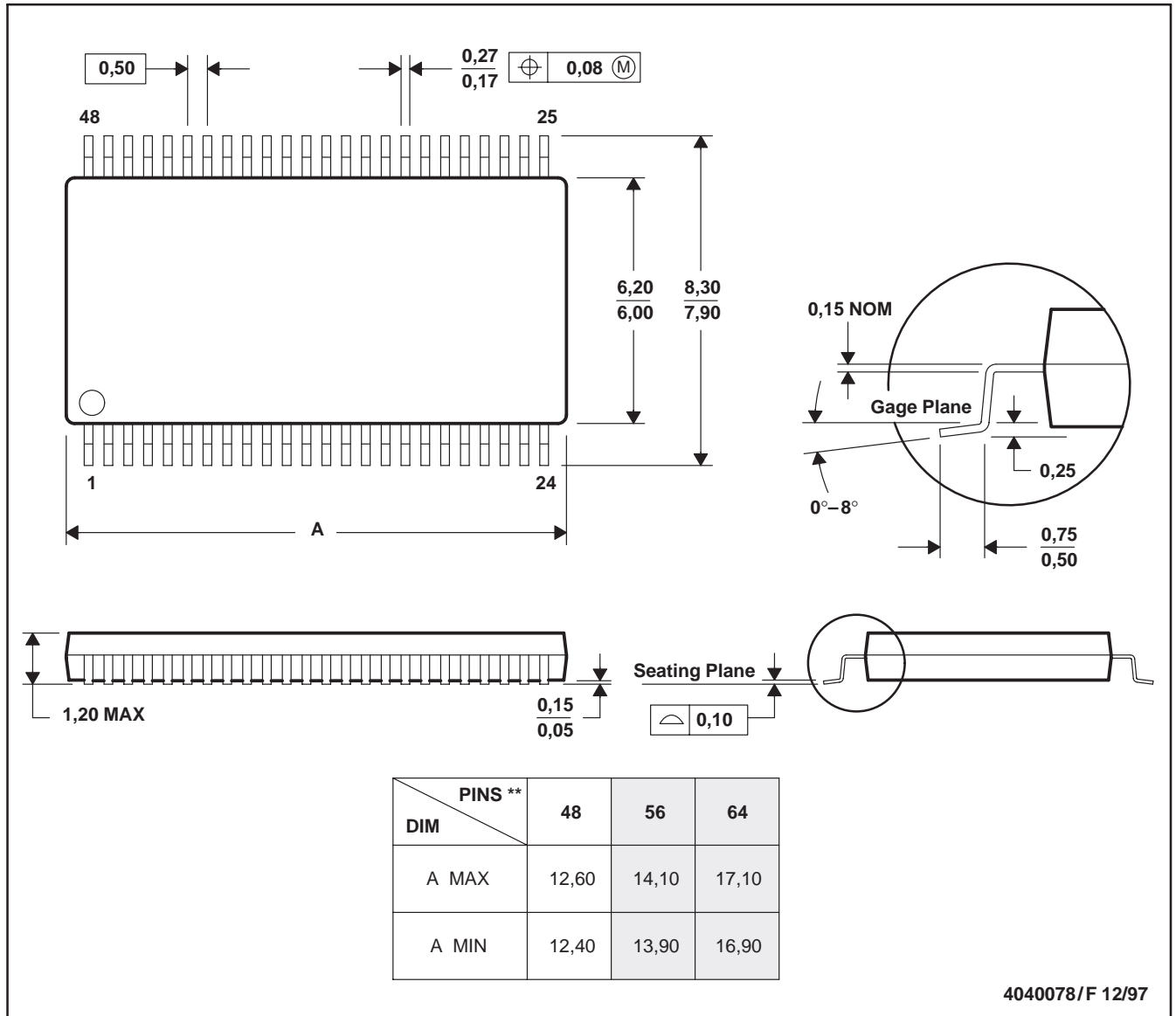

- NOTES: A. All linear dimensions are in millimeters.
 B. This drawing is subject to change without notice.
 C. Body dimensions do not include mold protrusion not to exceed 0,15.
 D. Falls within JEDEC MO-153

IMPORTANT NOTICE

Texas Instruments and its subsidiaries (TI) reserve the right to make changes to their products or to discontinue any product or service without notice, and advise customers to obtain the latest version of relevant information to verify, before placing orders, that information being relied on is current and complete. All products are sold subject to the terms and conditions of sale supplied at the time of order acknowledgement, including those pertaining to warranty, patent infringement, and limitation of liability.

TI warrants performance of its semiconductor products to the specifications applicable at the time of sale in accordance with TI's standard warranty. Testing and other quality control techniques are utilized to the extent TI deems necessary to support this warranty. Specific testing of all parameters of each device is not necessarily performed, except those mandated by government requirements.

CERTAIN APPLICATIONS USING SEMICONDUCTOR PRODUCTS MAY INVOLVE POTENTIAL RISKS OF DEATH, PERSONAL INJURY, OR SEVERE PROPERTY OR ENVIRONMENTAL DAMAGE ("CRITICAL APPLICATIONS"). TI SEMICONDUCTOR PRODUCTS ARE NOT DESIGNED, AUTHORIZED, OR WARRANTED TO BE SUITABLE FOR USE IN LIFE-SUPPORT DEVICES OR SYSTEMS OR OTHER CRITICAL APPLICATIONS. INCLUSION OF TI PRODUCTS IN SUCH APPLICATIONS IS UNDERSTOOD TO BE FULLY AT THE CUSTOMER'S RISK.

In order to minimize risks associated with the customer's applications, adequate design and operating safeguards must be provided by the customer to minimize inherent or procedural hazards.

TI assumes no liability for applications assistance or customer product design. TI does not warrant or represent that any license, either express or implied, is granted under any patent right, copyright, mask work right, or other intellectual property right of TI covering or relating to any combination, machine, or process in which such semiconductor products or services might be or are used. TI's publication of information regarding any third party's products or services does not constitute TI's approval, warranty or endorsement thereof.