

Introduction

Intersil's non-volatile 3-wire "Up/Down" interface DCPs recall the wiper position from internal EEPROM on power up. To change the wiper position and to store a new default wiper setting, they use \overline{INC} , $\overline{U/D}$, and \overline{CS} pins. The \overline{INC} and \overline{CS} signals are also NORed together, internally, to generate an enable signal for the internal wiper decoder as shown in Figure 1. Casual treatment of the \overline{INC} and \overline{CS} control signals on power-up can lead to inadvertent store operations, "walking wipers" and other unexpected results.

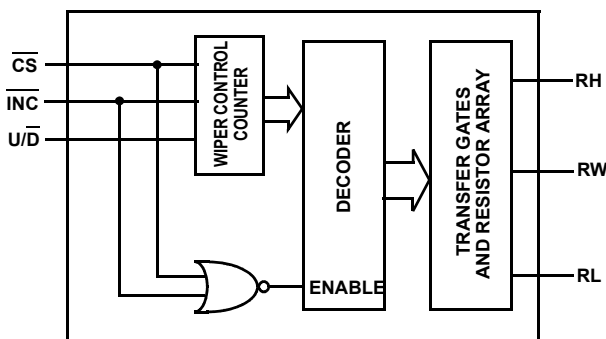

FIGURE 1. 3-WIRE DEVICE INTERNAL CONTROL LOGIC

Default Wiper Positions

On power-up, before the DCP recalls its wiper position, the wiper is at an unknown state. Usually it is at the low end of the wiper string. When the supply voltage reaches a certain level, the device recalls the wiper position from internal EEPROM cells. The factory default wiper positions are shown in Table 1.

TABLE 1. DCP FACTORY DEFAULT WIPER POSITIONS

DCP DEVICE	NUMBER OF TAPS	DEFAULT WIPER POSITION
X9116	16	Tap 7
X9C102	100	Tap 0
X9C103	100	
X9C104	100	
X9C503	100	
X9312	32	
X9313	32	
X9315	32	
X9318	100	
X9319	100	
X93154	32	
X93155	32	
X93156	32	
X93254	32	
X93255	32	
X93256	23	
X9317	100	Tap 99

Walking Wiper

Without careful connection of the \overline{INC} and \overline{CS} pins a circuit can exhibit a characteristic called "walking wiper". This phenomenon appears as an automatic increment or decrement of the wiper on power-up, after the nonvolatile wiper setting has been recalled. If both the \overline{CS} and \overline{INC} pins are deemed LOW by the device during power-up, a condition exists that is sufficient to cause the wiper to move one position from its recalled wiper value, either up or down, depending on the state of the $\overline{U/D}$ pin.

Normal, controlled, movement of the wiper requires the \overline{INC} pin to be "clocked" from HIGH to LOW, while \overline{CS} is LOW. The walking wiper condition typically occurs when the \overline{CS} and \overline{INC} pins are tied to microcontroller or programmable logic device that have outputs which float during power up (in which case they might be detected as LOW) or if the outputs are tied or held LOW on power up.

In the worst case condition, \overline{CS} and \overline{INC} are left floating on power up and pick up noise from the system. In this case, the device might actually "see" the \overline{INC} line toggling, with respect to \overline{CS} even though there is very little actual movement to the inputs. To the outside observer, the wiper might seem to recall to the high or low end of the resistor string, when in actuality it recalls to the non-volatile position, then "walks" to one end as a result of the floating inputs.

To reduce the possibility of a walking wiper, we recommend a pull-up on at least the \overline{CS} pin. Also, if possible, make sure the microcontroller or programmable logic device does not set both outputs low when it receives power.

Unexpected Wiper Movement

The \overline{INC} pin can be pulled either HIGH or LOW as a default and still have a circuit that operates properly. However, for wiper movement on these devices, \overline{INC} and \overline{CS} are interchangeable. That means that holding \overline{CS} LOW and clocking \overline{INC} will work the same as holding \overline{INC} LOW and clocking \overline{CS} . So, if \overline{INC} is LOW as a default, when \overline{CS} goes LOW to select the device, the wiper will move one tap. If \overline{INC} is normally LOW, be careful to set \overline{INC} HIGH before changing \overline{CS} from HIGH to LOW.

Inadvertent Store Operations

A third unexpected condition is an inadvertent store operation. It is important to remember that \overline{CS} going from LOW to HIGH, while \overline{INC} is HIGH, initiates the store wiper position mode. This initiates the nonvolatile store operation which requires several milliseconds to complete. As long as \overline{CS} and \overline{INC} are normally HIGH, in the quiescent state, the device won't see a LOW to HIGH transition on \overline{CS} during

Application Note 92

power-up or power-down conditions. This prevents the triggering of any unexpected wiper storage modes.

If wiper storage is not required for any reason, hold $\overline{\text{INC}}$ LOW while allowing $\overline{\text{CS}}$ to transition from LOW to HIGH. Once $\overline{\text{CS}}$ is HIGH, then $\overline{\text{INC}}$ can go HIGH without a store operation.

An additional condition that can lead to inadvertent EEPROM write operations occurs when the control lines $\overline{\text{CS}}$ and $\overline{\text{INC}}$ are pulled up, or powered by, a power supply separate from the DCP power supply. In this configuration it is possible that $\overline{\text{CS}}$ and $\overline{\text{INC}}$ are powered, while the VCC pin is not. This has been known to cause wiper recall problems. So, it is best to design the circuit so the control lines are powered only when the device is powered.

Recommendations

The recommendation is to keep $\overline{\text{CS}}$ and $\overline{\text{INC}}$ normally HIGH by using pull-up resistors to VCC on both pins. For most

applications a 10k Ω pull-up resistor provides a good tradeoff between a solid pull-up condition, low power operation, and compatibility with microcontroller drivers. A 0.1 μF bypass capacitor can also help reduce wiper movement in noisy environments. (See Figure 2.)

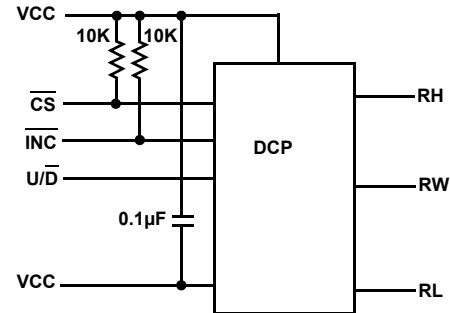

FIGURE 2. 3-WIRE RECOMMENDED EXTERNAL CONNECTIONS